

A PERFECT ALLIANCE.

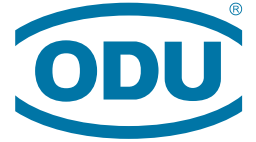

ODU-MAC[®] Silver-Line White-Line

Compact modular connector system.
Up to 6,300 V, 20 bar, 10 Gbit/s, 100,000 mating cycles and 9.0 GHz.

AUTOMATIC DOCKING
MANUAL MATING



ODU-MAC[®] SILVER-LINE | ODU-MAC[®] WHITE-LINE

ODU-MAC[®] BLUE-LINE

FEATURES

- Robust design
- High number of mating cycles (> 100,000)
- Stable low contact resistance
- Vibration resistance
- High reliability
- Wide variety of transmission modules
- Compact solution possibilities
- Maximum packing density
- Blind mating

APPLICATIONS

- Medical
- Industrial
- Test and Measurement
- Military and security
- Energy
- eMobility



All shown connectors are according to IEC 61984:2008 (VDE 0627:2009); connectors without breaking capacity (COC).

Tested acc. UL 1977/CSA C22.2 No. 1823. Tested acc. MIL/SAE/EIA. (ODU-USA is registered with the DDTC and able to complete ITAR restricted manufacturing projects.)

All dimensions are in mm.

Some figures are for illustrative purposes only. Subject to change without notice. Errors and omissions excepted. We reserve the right to change our products and their technical specifications at any time in the interest of technical improvement. This publication supersedes all prior publications. This publication is also available as a PDF file that can be downloaded from www.odu-connectors.com.

Issue: 2018-09

Data transmission protocols

These ODU specific connectors can transmit common data transmission protocols such as HDMI[®], USB[®] 1.1, USB[®] 2.0, USB[®] 3.1 Gen1, FireWire[®], FlexRay[®], Ethernet, Profibus[®], CAN-Bus, CAT 5 and CAT 6_A, but they are not HDMI[®]-, USB[®]-, FireWire[®]-, FlexRay[®]-, Ethernet-, Profibus[®]-, CAN-Bus- and CAT-standard connectors.



Non-magnetic



ODU-MAC[®] ZERO

TABLE OF CONTENTS

Clickable page numbers

THE ODU CORPORATE GROUP	4
PRODUCT INFORMATION	10
Compact modular connector system	12
Web configurator	14
Correct configuring – step by step	16
Automatic docking	18
Manual mating	20
Information on plastic housing	28
The contact principle	30
Contact retention clip	34
Application specific solutions	36
ODU-MAC® Silver-Line – AUTOMATIC DOCKING	39
Requirements on the complete system	40
ODU-MAC® S (Standard)	42
ODU-MAC® L (Large)	43
ODU-MAC® M+ (Mini)	44
ODU-MAC® P+ (Power)	45
PE transmission, grounding kit	46
ODU-MAC® T (Transverse)	48
ODU-MAC® QCH (Quick Change Head)	49
Strain relief housing	50
ODU-MAC® White-Line – MANUAL MATING	53
ODU-MAC® ZERO/Snap-In locking	54
Spindle locking	56
Metal housing	58
Plastic housing	62
Transverse locking, plastic housing	65
Lever locking, metal housing	70
Housing with IP 68 / IP 69/ EMC	78
Frame for housing	82
Accessories	83
Coding possibilities	86
Flexible circular connectors with ODU-MAC® inserts	92
MODULES	95
Overview	96
Signal	102
Power	112
High current	120
High voltage	126
Coax	130
Compressed air and fluid module	140
Fiber optic	150
Shielded implementation / high-speed connector	156
Blank modules / spacer modules / coding modules / pin protection modules	164
TOOLS, CRIMP INFORMATION, PROCESSING INSTRUCTIONS, ACCESSORIES	169
TECHNICAL INFORMATION	181
International protection classes acc. IEC 60529:2013 (VDE 0470-1:2014)	182
Explanations and information on insulation coordination	183
Conversions / AWG	186
Operating voltage according to EIA-364-20D:2008	187
Current-carrying capacity	188
Technical terms	193

For assembly instructions please refer to our website: www.odu-connectors.com/downloads.

A PERFECT ALLIANCE.

CREATING CONNECTIONS, BUILDING ALLIANCES, COLLABORATING INTO THE FUTURE: WHETHER TWO TECHNICAL COMPONENTS COME TOGETHER TO FORM A UNIT OR PEOPLE COME TOGETHER TO STRIVE FOR GREAT RESULTS – THE KEY IS TO ASPIRE IN ACHIEVING SUPERB RESULTS. THIS GOAL DRIVES OUR WORK. **PERFECT CONNECTIONS THAT INSPIRE AND DELIVER ON THE PROMISES.**





A PERFECT ALLIANCE.

ODU WORLDWIDE

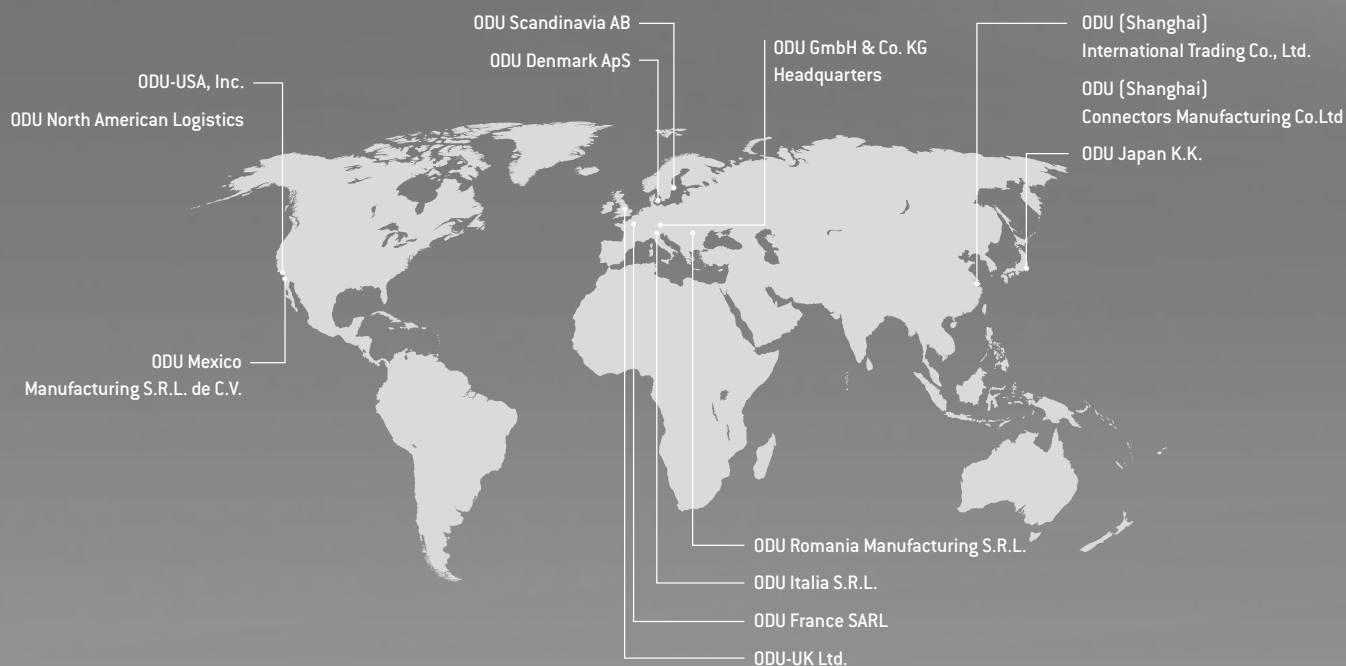

ODU GROUP OVERVIEW

- More than 75 years of experience in connector technology
- A turnover of 170 million Euro
- Over 1,900 employees worldwide
- 9 sales subsidiaries in China, Denmark, France, Germany, Italy, Japan, Sweden, the UK and the US as well as 5 production and logistics sites
- All technologies under one roof: Design and development, machine tool and special machine construction, injection, stamping, turning, surface technology, assembly and cable assembly

As of February 2018

CERTIFIED QUALITY

- DIN EN ISO 9001
- IATF 16949
- DIN EN ISO 14001
- ISO 13485
- Wide range of UL, CSA, VG and DVA licenses
- UL certified cable assembly

For a complete list of our certifications, please visit our website.

INGENIOUS IDEAS PERFECT SOLUTIONS

ODU'S PRODUCT PORTFOLIO.



COMPACT MODULAR CONNECTOR SOLUTIONS

- Application-specific hybrid interface
- For manual mating and automatic docking
- The highest packing density
- Flexible modular construction
- Multitude of data transmission modules
- Variety of locking options available
- For the transmission of signals, power, high current, high voltage, coax, high-speed data, fiber optics and other media such as air or fluid.
- Mating cycles scalable as required from 10,000 to over 100,000 (1 million)



PUSH-PULL CIRCULAR CONNECTORS

- Circular connector series in robust metal or plastic housing
- Contacts for soldering, crimping and PCB termination
- Optional selectable Push-Pull locking ensuring a secure connection at all times as well as easy to release Break-Away function
- 2 up to 55 contacts
- IP 50 to IP 69
- Autoclavable for medical applications
- Hybrid inserts for combined transmission



ELECTRICAL CONTACTS

- Versatile connector technologies
- Outstanding reliability, lifetime and durability
- Up to 1 million mating cycles
- Current-carrying capacity of up to 2,400 amperes and more
- Rugged contact systems, suitable even for harsh environments
- Economical solutions for automatic processing



A PERFECT ALLIANCE.

+ Versatile connector solutions for transmission of power, signals, data, or media – ODU never fails to offer the right interface when quality and absolute reliability are the top priorities.

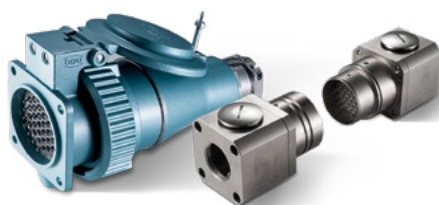

HEAVY-DUTY & DOCKING AND ROBOTIC CONNECTOR SOLUTIONS

- Extremely durable even under extreme /harsh environments
- Interference-free and secure connection, even under vibration
- Up to 500 A (higher currents upon request)
- High contact security due to the springwire technology
- High pin density due to a minimum contact diameter
- Low contact resistance



APPLICATION AND CUSTOMER-SPECIFIC SOLUTIONS

- Contacts, connectors and assemblies for the highest technical requirements as well as special applications
- First-class implementation expertise
- High level of vertical manufacturing – all competences and key technologies under one roof
- Expert advice based on mutual partnership
- Fast development and production



CABLE ASSEMBLY

- Complete systems from a single source based on years of assembly expertise
- State-of-the-art production facilities with 100% end testing, high-voltage testing, component testing and pressure testing up to 100 bar
- Cleanroom production
- Hot-melt and high-pressure injection molding
- Customer-specific labeling
- Rapid prototyping of samples

MORE THAN A CONNECTION

OUR KNOW-HOW FOR YOUR SUCCESS.

All shown connectors are according to DIN EN 61984:2009 connectors without breaking capacity (COC)!

General tolerances to DIN ISO 2768-mK		Tolerances to DIN ISO 8015		name		designation	
2013	date	2013	date	Unterblum	Break-A		
prep.	11.06.						
app.							
norm.							

HIGH PERFORMANCE CONNECTOR TECHNOLOGY FOR DEMANDING KEY MARKETS

Customers rely on ODU technology wherever first-class, high-performance connector solutions are required. All our skills go into our products to ensure your success. In addition to the top quality, reliable stability and maximum flexibility in customer-specific requirements, our products also stand for dynamics, reliability, safety, precision, efficiency and sustainability. And they guarantee unrestricted functionality for the final product due to our high quality connectors. ODU – A PERFECT ALLIANCE.

APPLICATION-SPECIFIC SOLUTIONS

Demands that can't be pigeon-holed call for creative specialists who think outside the box. ODU offers the type of expertise that focuses solely on the specific requirements of our customers. For every development order we get, we not only perform a thorough check to make sure it's feasible, we intensively incorporate our customers in the ongoing design process. This guarantees an impressive, custom-fit final result. Our solutions are frequently based on the modifications of our products, especially for the ODU MINI-SNAP and ODU-MAC connectors.

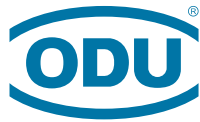
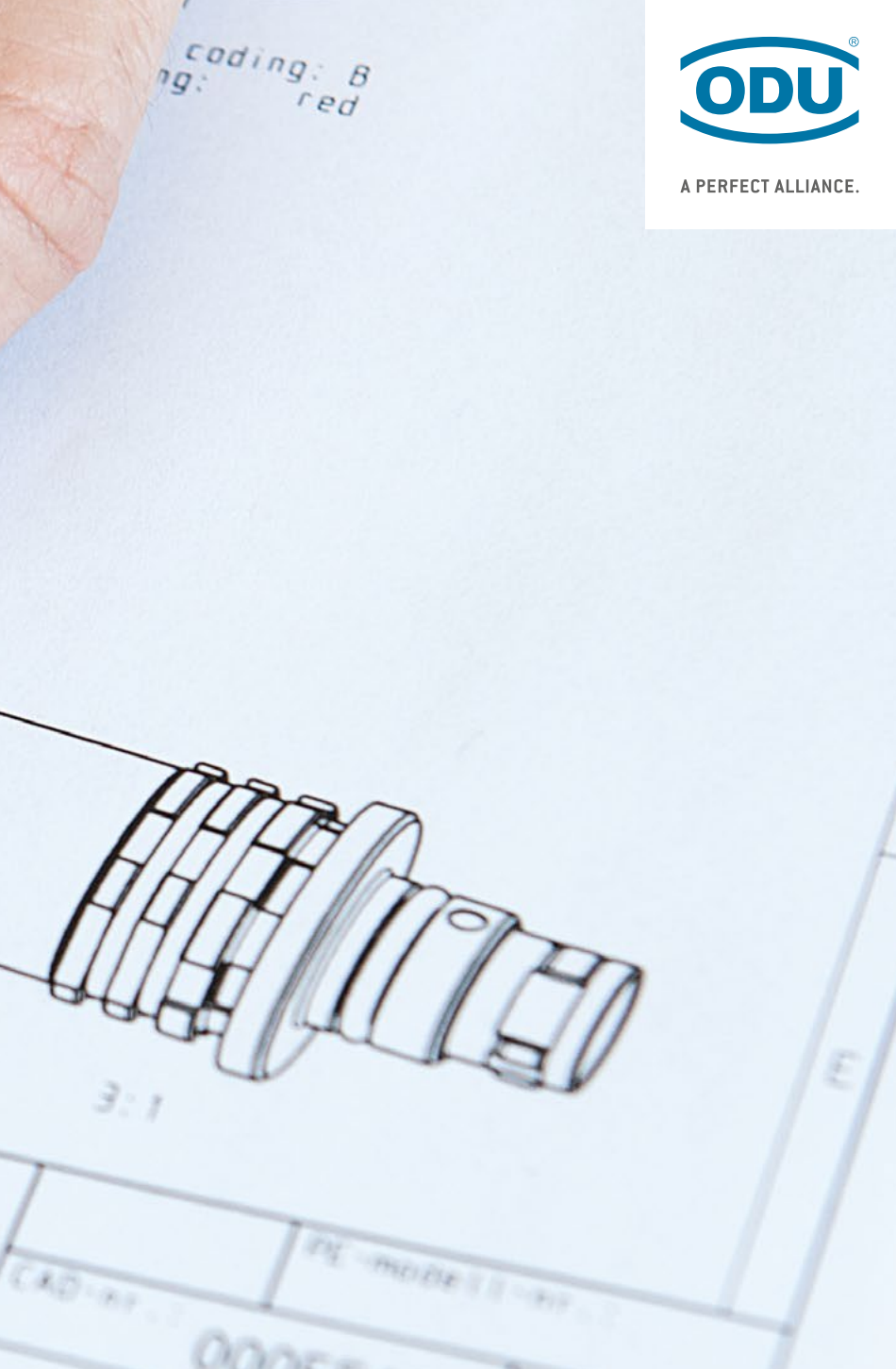

A PERFECT ALLIANCE.

MEDICAL

TEST AND MEASUREMENT

MILITARY AND SECURITY

INDUSTRIAL

ENERGY

EMOBILITY

HIGH LEVEL OF VERTICAL INTEGRATION

ODU combines all the competences and key technologies for the connector manufacturing. These include design and development, machine tool and special machine construction, injection, stamping, turning, surface technology, assembly and cable assembly and our own test laboratory.

INDIVIDUAL CABLE ASSEMBLY

Our production skills together with our cutting edge production facilities from Europe, China and the USA enable us to deliver to our customers locally tested assemblies and also global ones.



CONFIGURE THE ODU-MAC®.
SIMPLY ONLINE AT WWW.ODU-MAC.COM

ODU-MAC®



PRODUCT INFORMATION

Compact modular connector system	<u>12</u>
Web configurator	<u>14</u>
Correct configuring – step by step	<u>16</u>
ODU-MAC® / Silver-Line – Automatic docking	<u>18</u>
ODU-MAC® / White-Line – Manual mating	<u>20</u>
Information on plastic housing	<u>28</u>
The contact principle	<u>30</u>
Contact retention with the clip principle	<u>34</u>
Application specific solutions	<u>36</u>

ODU-MAC® – A MODULAR ALL-ROUNDER FOR THE MOST VARIED APPLICATIONS

THE SMART SOLUTION FOR CUSTOMIZED CONNECTIONS

The ODU-MAC's flexible, modular design enables multiple connection types to be combined within single contacts. Whether signal, power, high current, high voltage, coax, high-speed data transmission, fiber optic and other media such as air or fluid – all types can be selected from the module and integrated into the individual connector solution. The connection options are just as versatile.

Many options are available for a variety of applications in industry or medical technology. For example, automated docking systems can use our stable aluminium frames, or a manual connection can be made with our robust housing design.

The result is an effective, compact and attractive complete connection that cannot be beaten in terms of functionality. Confusion due to an excessive number of connections is a thing of the past – an ODU-MAC customized to meet your requirements is today's solution.

ODU-MAC is available in two basic versions: a flexible and adjustable aluminium frame for automatic docking or in the housing for manual mating.

[Find out more about custom configurations on the following pages.](#)

THE ODU-MAC LEAVES NOTHING TO BE DESIRED:

- 100,000 mating cycles and more
- Versions in the docking frame for automatic docking
- Versions in rugged housing suitable for use in harsh environments
- Easy locking of the housing with Snap-In, spindle or lever
- Many different module options available
- Extremely compact due to the high contact density



ADDITIONAL INFORMATION PROVIDED IN VIDEOS
WWW.YOUTUBE.COM/ODUSTECKVERBINDER

ODU-MAC® **Blue-Line**

Our new performance class offers a true alternative – request our ODU-MAC Blue-Line catalog to find out more.



Silver-Line
 AUTOMATIC DOCKING.



White-Line
 MANUAL MATING.

ODU-MAC ZERO

THE MODULARITY AT A GLANCE:

100,000
Mating cycles and more

2 Possible applications:
automatic docking or manual mating

56 Cable hood versions

6 Different docking frames
independently configurable length
(see page 18)

4 Locking types: Snap-In (Break-Away),
spindle, lever or transverse locking

Removable contacts
with clip principle
(see page 34)

5 Different spindle geometries

34 Modules to choose from:
signal, power, high current,
high voltage, coax, media such
as air or fluid, high-speed data
transmission and fiber optic

13 Variations of bulkhead mounted and
surface mounted housing and
various sizes of cable-to-cable-hoods

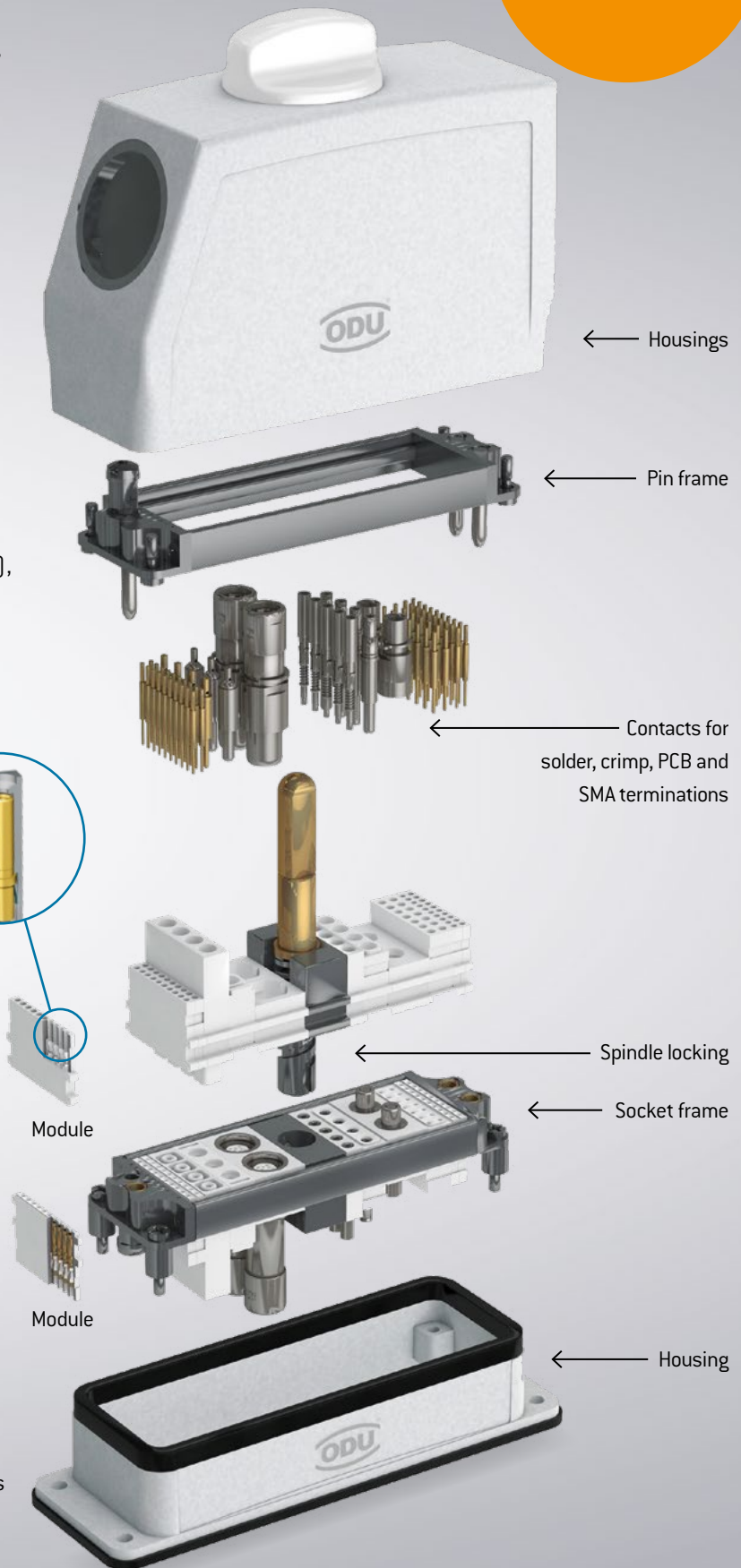

ODU-MAC® WEB CONFIGURATOR

Individual configuration of your ODU-MAC® connection.

With ODU-MAC web configurator it's possible to configure your connection simply according to your requirements. The configurator guides you through the different choices step by step and offers many continuative information. There are two ways to access the ODU-MAC web configurator:

1. ACCESS: THROUGH WWW.ODU-CONNECTORS.COM



Entry via www.odu-connectors.com provides you with a great deal of product information and many application examples prior to configuration of your ODU-MAC.



Access to the configurator via the product category Modular Connectors.

2. ACCESS: DIRECTLY THROUGH WWW.ODU-MAC.COM



www.odu-mac.com takes you directly to the configuration spacer, allowing you to start assembling your ODU-MAC immediately.

PRODUCT VIDEOS ON FUNCTIONALITY

Silver-Line



White-Line



Videos explaining the functions of automatic docking and manual mating can be found under **▶ Explanation** on the welcome page of the configurator at www.odu-mac.com.

YOUR WAY TO AN INDIVIDUAL CONNECTION

How to configure your ODU-MAC®.

INDIVIDUAL REQUIREMENTS – INDIVIDUAL CONFIGURATION

With ODU-MAC, we offer a modular connector system configured to your requirements. This means that you always receive the appropriate hybrid connection.

SELECT & REQUEST OFFERS

You will receive a drawing and a detailed offer within one working day of submitting your request. When placing an order you will receive the complete article number for connections preassembled by ODU (contacts supplied as accompanying loose items). **We ask you to enquire directly about customized versions not covered by the standard.**



For information to the configuration of your connector please refer to our website: www.odu-mac.com

ODU-MAC® Silver-Line

AUTOMATIC DOCKING.

1ST STEP: FRAME SELECTION

Depending upon your requirements, you can choose 6 different frame types as a base for automatic docking.

Frames	
ODU-MAC® S (Standard)	ODU-MAC® T (Transverse)
ODU-MAC® L (Large)	ODU-MAC® P+ (Power)
ODU-MAC® M+ (Mini)	ODU-MAC® QCH (quick change head) (connector saver)



2ND STEP: MODULE SELECTION

Choose from 34 different modules for transferring signal, power, high current, high voltage, coax, high-speed data transmission, fiber optic and other media such as air or fluid and assemble your ODU-MAC individually.

Modules	
Signal	Compressed air and fluid model
Power	Fiber optic
High current	Shielded implementation / high-speed connector
High voltage	Blank modules / spacer modules / coding modules / pin protection module
Coax	

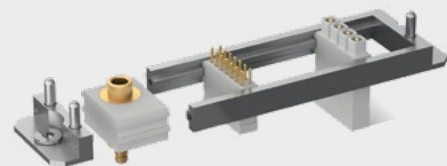

ODU-MAC® **White-Line**

MANUAL MATING.

1ST STEP: LOCKING

Select the type of lock in this first step. You have the choice between Snap-In, spindle, lever and transverse locking.

Snap-In locking Plastic housing	Spindle locking Metal/plastic housing	Lever locking Metal housing	Transverse locking Plastic housing
---	---	---------------------------------------	--



2ND STEP: CONNECTOR HOUSING

Depending upon the lock, choose the housing suited to your requirements. The following housings are available:

Snap-In locking	Spindle locking	Lever locking	Transverse locking
90° Cable exit	Cable hood Metal/plastic housing	Cable hood Metal housing	Cable hood Plastic housing
45° Cable exit	Cable hood XXL Metal housing	Cable hood XXL Metal housing	
0° Cable exit		Cable hood wide Metal housing	



3RD STEP: RECEPTACLE SELECTION

Depending upon the requirements for the receptacle and the selected connector housing, a wide variety of designs is available.

Snap-In locking	Cable hood	Cable hood XXL
Receptacle	Bulkhead mounted housing Metal/plastic housing	Bulkhead mounted housing / Metal housing
	Surface mounted housing Metal/plastic housing	Surface mounted housing / Metal housing
	Cable to cable hood Metal housing	



The cable hood wide housing is only compatible with the bulkhead and surface mounted housing for cable hood wide housings.

4TH STEP: MODULE SELECTION

Choose from 34 different modules for transferring signal, power, high current, high voltage, coax, high-speed data transmission, fiber optic and other media such as air or fluid and assemble your ODU-MAC individually.

Modules
See page 95

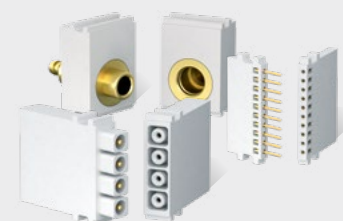

ODU-MAC[®] **Silver-Line** AUTOMATIC DOCKING.

Overview of docking frames.

ODU-MAC in the docking frame is used only for automatic docking. Choose from a variety of different frames, adjust the length individually and assemble the frame with the modules you need for your requirements.

With ODU-MAC you can always find the perfect solution. And should your requirements for a connection go beyond the standard solutions, we also offer customized special solutions.

ODU-MAC is configured for 3 to 60 grid units (more upon request), meaning that up to 600 contacts can be installed when the 10 contacts module with a module width of 2.54 mm (1 unit) is used. Versions for limited space (ODU-MAC M+ (Mini)), increased requirements for floating support (ODU-MAC L (Large)) and increased mechanical load (ODU-MAC P+ (Power)) are also available.

FURTHER INFORMATION FROM PAGE [39](#).

ODU-MAC[®] S (STANDARD) P. 42

Standard solution for docking tasks.
Tolerance compensation: +/- 0.6 mm.



ODU-MAC[®] L (LARGE) P. 43

Frame with higher tolerance compensation and reinforced guiding bushes, as well as extended guiding pins.
Tolerance compensation: +/- 1.2 mm.



The length of the frames can be ordered individually depending upon the number of modules.

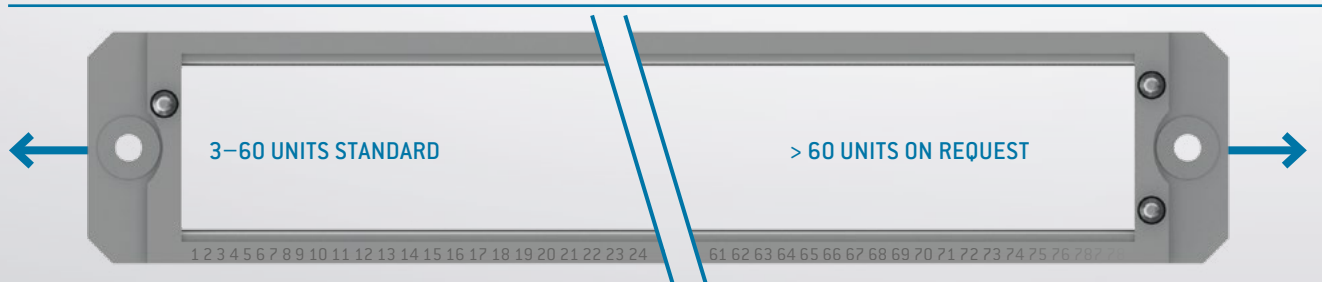

ODU-MAC® M+ (MINI) P. 44

Compact size with the smallest space requirement
Tolerance compensation: +/- 0.6 mm.

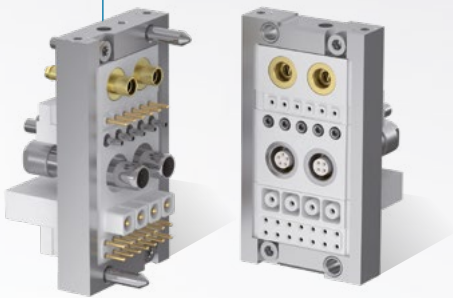

ODU-MAC® P+ (POWER) P. 45

The frame for the highest requirements thanks to reinforced frame design.
Tolerance compensation: +/- 2.5 mm.



ODU-MAC® T (TRANSVERSE) P. 48

Transverse frames for installation in customized housing solutions or where low clearance heights make this necessary.

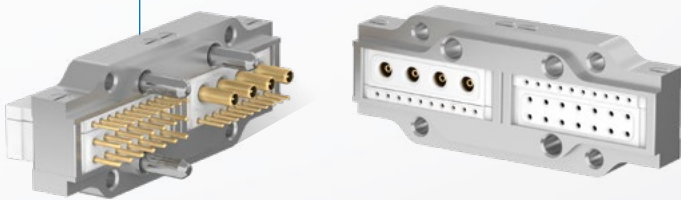

ODU-MAC® QCH (QUICK CHANGE HEAD) P. 49

Docking frames for the highest requirements with regard to mating cycles (connector saver) with the lowest maintenance time and expense thanks to easy exchange of the replacement parts.
Tolerance compensation: +/- 0.6 mm.



MODULARITY AND ERGONOMIC DESIGN FOR THE SMALLEST OF SPACES.

The ODU-MAC® ZERO – Modular Multitasker.

The ODU-MAC ZERO is a space-saving hybrid connector that combines the widest variety media – the ideal choice from the ODU-MAC product family. Its symmetric housing geometry enables a generous range – up to 9 units – of signals, power, light waves, data-rate and coax modules. In place of an aluminum frame, the plastic housing parts have integrated rails, making the use of magnetic components no longer necessary.

This is how a solid, effective, and attractive overall connection is created – pure functionality that is hard to ignore. Confusion due to an excessive number of connections? This challenge belongs to the past – because the customized ODU-MAC ZERO is today's solution.

FURTHER INFORMATION FROM PAGE 54.

- Housing made of 2 plastic half-shells which also form the frame
- All touchable parts **nickel-free**
- **Bio-compatibility** upon request
- **Coding:** by guiding pins (Ø 4 mm, length 16 mm), housing geometry, coding modules and color-coded cable bend relief varieties
- Suitable for a wide range of ODU-MAC modules
- Up to **60,000 mating cycles**
- **3 different cable outlets: straight, 45°, 90°**
- **Simple, safe housing locking** (Break-Away function/emergency release)



Solid grip



Blind mating



Non-magnetic



Space-saving

Size	Units 2.54 mm	
ZERO	9	



HOUSING
PLASTIC HALF-SHELL INCLUDING RAILS FOR MODULAR INSERTS

SNAP-IN LOCKING

Easy mating, automatic locking, quick demating option when necessary:

- Quick, reliable housing locking thanks to snap fits and sealing strip (frictional locking principle)
- Low mating/demating forces (approx. 7 N for the housing) guarantee quick connection demating (Break-Away function/emergency release)



CONNECTOR HOUSING FOR ASSEMBLY

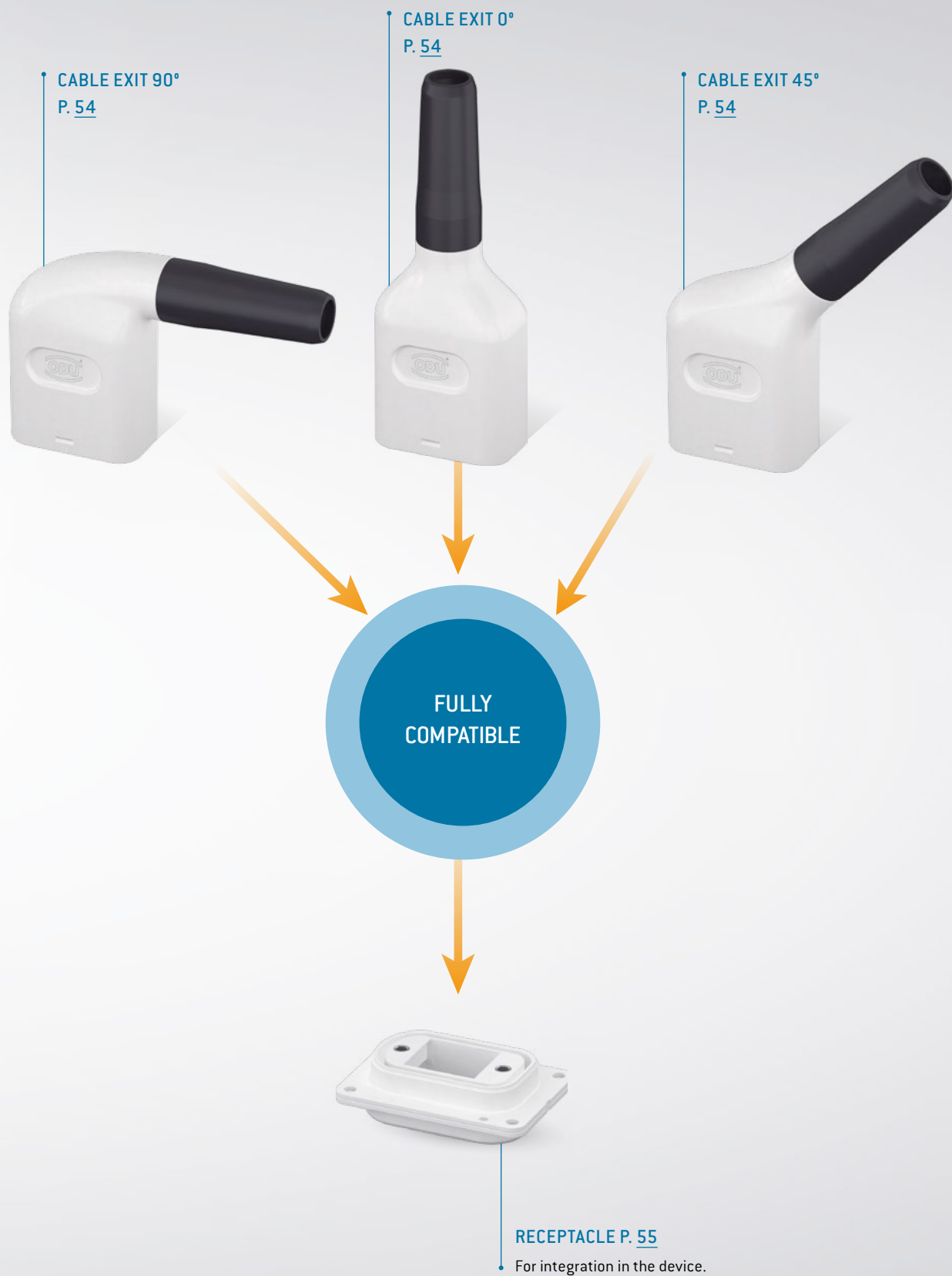

ODU-MAC® **White-Line**

MANUAL MATING.

Overview of housings with spindle locking.

In the case of spindle locking, the housings can be equipped with an easy to operate precision locking spindle. This spindle enables easy closing and opening of the housing with a single turning movement. The mating and sliding forces overcome in this way ease handling significantly. Only 5 units of space are required for this purpose.

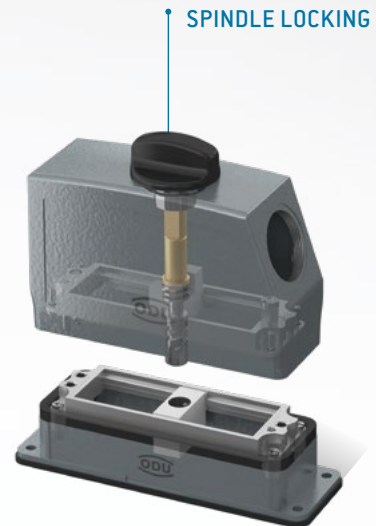

Especially in case of high connection frequency and limited space for locking, the use of precision locking is a preferred option.

Depending upon the application scenario, the mechanisms are designed for up to 30,000 locking cycles. Easy to mount replacement sets are available for larger numbers of mating cycles [See page 56].



FURTHER INFORMATION FROM PAGE 58.

- **Low profile** – less space for operation than lever locking
- **Ease of use** – one hand operation
- **Ergonomic design** – easy single spindle knob
- **Improved reliability** – preferred design for high mating cycles
- **Fully enclosed** – internal mechanism prevents damage
- **Repairable** – can be replaced without removal of the hood or frame
- **User friendly** – lower force required for operation
- **Precision** – materials, design and tolerances assist the life of contacts over time

Size	Units ¹	
2	16	
3	24	
4	34	

CABLE HOOD XXL²:

4	34	
---	----	---

¹ 5 units of space required for spindle. ² XXL housing only possible in metal version.

PLASTIC CABLE HOOD WITH SIDE CABLE ENTRY P. 62

Connector housing for assembly on the cable.



METAL CABLE HOOD WITH SIDE CABLE ENTRY P. 58

Connector housing for assembly on the cable.



METAL CABLE HOOD XXL WITH SIDE M50 CABLE ENTRY P. 59

Connector housing with expanded assembly space and side M50 cable entry.



FULLY COMPATIBLE

PLASTIC SURFACE MOUNTED HOUSING P. 64

For surface mounting on your device/wall with spindle locking and two side cable entries.



METAL SURFACE MOUNTED HOUSING P. 61

For surface mounting on your device/wall with spindle locking and two side cable entries.



PLASTIC BULKHEAD MOUNTED HOUSING P. 63

For mounting on device with spindle locking.



METAL BULKHEAD MOUNTED HOUSING P. 60

For mounting on device with spindle locking.



ODU-MAC® **White-Line**

MANUAL MATING.

Overview of housings with transverse locking.

The efficient and robust plastic housings with transverse lever locking are available in size 1 to 4 with IP 65.

A space saving locking for tow-handed safety operation with over 5,000 possible mating cycles which complements our multi-faceted housing range. It makes manual mating as easy as safe.



TRANSVERSE LOCKING ↓

FURTHER INFORMATION FROM PAGE [65](#).

- Locking lever can be **changed easily**
- Light and robust housing model
- **Space-saving locking**, stackable sidewise
- Two-handed safety operation
- Protection class **IP 65**
- > 5,000 mating cycles

Size	Unit	
1	10	
2	16	
3	24	
4	34	

PLASTIC CABLE HOOD WITH SIDE CABLE ENTRY P. 65

Connector housing for assembly on the cable.



PLASTIC BULKHEAD MOUNTED HOUSING P. 66

For mounting on device with transverse locking.



PLASTIC SURFACE MOUNTED HOUSING P. 67

For surface mounting on your device/wall with transverse locking and two side cable entries.



ODU-MAC® **White-Line**





MANUAL MATING.

Overview of housings with lever locking.

ODU-MAC with lever locking offers a wide variety of combination possibilities for manual mating. With the exception of the dual housing, all housings can be combined with one another.

Appropriate frames in various sizes are available for use in the standard DIN EN 175301-801:2007 housing with lever. Size 4, for example, can receive up to 34 modules with a module width of 2.54 mm (1 unit), meaning that a total of 34 modules (34 units), or 340 contacts in the case of 10 contacts, can be accommodated. Size 6 of the dual housing can accommodate up to 680 contacts.



FURTHER INFORMATION FROM PAGE 70.

Size	Units	
1	10	
2	16	
3	24	
4	34	

CABLE HOOD XXL:

4	34	
---	----	---

CABLE HOOD WIDE:

5	48	
6	68	

METAL CABLE HOOD WIDE WITH TOP CABLE ENTRY P. 74

Connector housing for double frame assembly.



METAL CABLE HOOD WIDE WITH SIDE CABLE ENTRY P. 74

Connector housing for double frame assembly.



METAL BULKHEAD MOUNTED HOUSING FOR CABLE HOOD WIDE P. 75

For mounting on your device with lever locking (with and without cover).

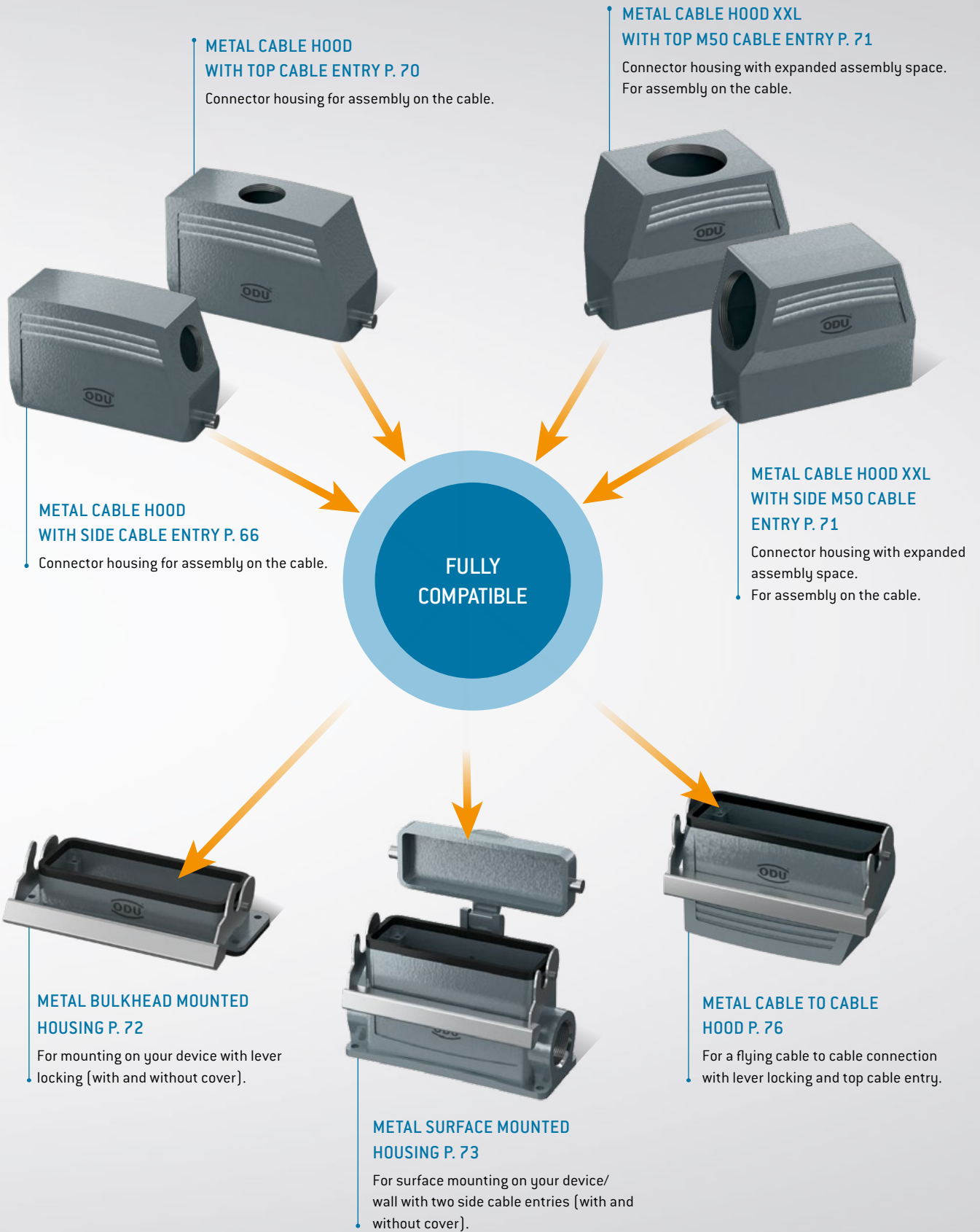

INFORMATION ON PLASTIC HOUSING

Plastic housing is primarily used for applications in which a high degree of chemical resistance is required. The glass-fiber reinforced plastic housing reduces the weight and impresses in mechanical robustness.

For the plastic housings of ODU-MAC the customer can choose between the proven spindle locking technology with more than 30,000 mating cycles which has excellent ergonomic features and the efficient transverse locking. An additional grounding of the plastic housing is unnecessary, due to the antistatic, thermoplastic housing.

Hence manual mating gets as easy as safe.



Medium	Material PA6 + GF	
	Resistant	With limited resistance
Ammonia, 10% aqueous solution	•	
Ammonia gas	At room temperature	At 100 °C
Ammonium carbonate	•	
Ammonium chloride	•	
Aniline		•
Asphalt	•	
Beer	•	
Butane gas	•	
Cooking salt, aqueous solution	•	
Copper sulphate, 10% aqueous solution	•	
Cresol solution		•
Cresylic acid		•
Cyclohexane	•	
Diesel	•	
Diluted glycerol	•	
Diluted glycol	•	
Diluted phenol		•
Diethylphthalate	•	
Ethyl alcohol, not denatured	•	
Fruit juices	•	
Glycerol	•	
Heptane	•	
Hexane	•	
Hydrogen sulphide	Gaseous	Diluted solution
Ink	•	
Isopropyl + ethanol	•	
Isopropyl alcohol	•	
Lactic acid	•	
Linseed oil	•	
Lubricating oil	•	
Mercury	•	
Methyl alcohol, diluted 50%	•	
Mineral oil	•	
Mineral-based oil	•	
Moth balls	•	
Motor oil	•	
n-Butanol	•	
Naphthalene	•	
Octane	•	

Medium	Material PA6 + GF	
	Resistant	With limited resistance
Oleic acid	•	
Paraffin oil	•	
Petroleum	•	
Potassium carbonate	•	
Potassium chloride	•	
Potassium iodide	•	
Potassium nitrate	•	
Potassium sulphate	•	
Regular grade petrol	•	
Seawater	•	
Silicone oil	•	> 100 °C
Soap solution	•	
Sodium bicarbonate	•	
Sodium bisulfate, aqueous solution	•	
Sodium carbonate	•	
Sodium chlorate	•	
Sodium chloride	•	
Sodium hydroxide 12.5%	At room temperature	
Sodium nitrate	•	
Sodium nitrite		•
Sodium perborate	•	
Sodium phosphate	•	
Sodium silicate	•	
Sodium sulphate	•	
Sodium sulphide	•	
Sodium thiosulphate	•	
Solution for developing photos	•	
stearic acid	•	
Stearic acids	•	
Sulphur	•	
Sulphur dioxide		•
Tallow	•	
Tar	•	
Tartaric acid	•	
Transformer oil	•	
Urea, diluted	•	
Urine	•	
Vegetable oil	•	
Water	•	

This list represents an abstract of the chemical resistance of the plastic housing. Please contact the ODU team if you have any further questions. They will be happy to assist you.

BEST CONNECTIONS – THE CONTACT PRINCIPLE

ODU contacts fulfil the highest quality standards and enable secure and reliable connections. ODU has the highest performance contact technologies at its disposal. Principally, a differentiation of lathe-turned contacts is made between lamella, springwire and slotted contacts. The socket side differ in architecture, but the pins are always the same and always solid.

ODU SPRINGTAC®

Contacts with springwire technology.

The ODU SPRINGTAC is the most effective contact system on the market. Constant transfer is always guaranteed thanks to the large number of individual, independently flexible springwires. Even with the smallest contact diameter of $\varnothing 0.76$ mm, 15 individual springs are still installed, meaning that even this small diameter provides 15 contact surfaces for current transfer. Correspondingly more for larger diameters.

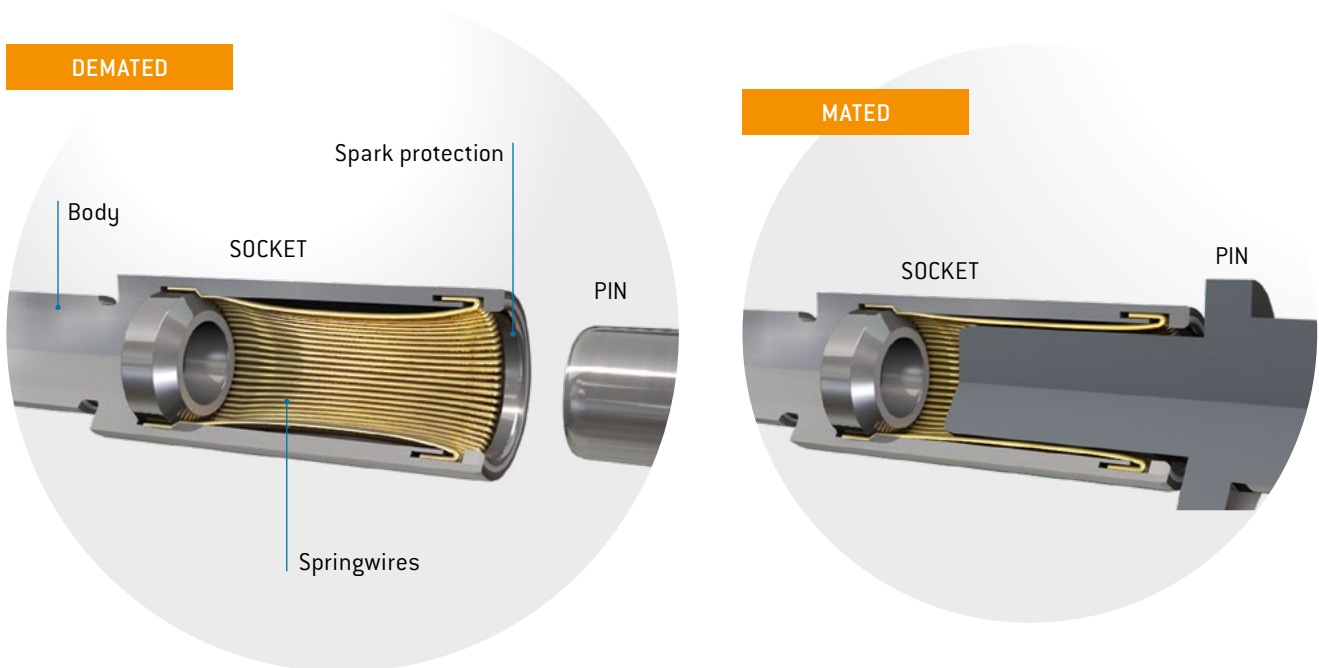

ADVANTAGES

- Greater than 100,000 mating cycles (up to 1 million mating cycles can be achieved)
- High current-carrying capacity – surge current capacity
- Low contact resistances
- Large number of independently flexible contact springs, e.g. 40 springs with a diameter of 5 mm
- Low mating and demating forces
- Extremely secure connection
- High vibration and shock resistance
- Individual contacts upon request

Standard contact principle for:	
Signal	14 to 5 contacts
Power	4 to 2 contacts
High current	2 contacts
High voltage	4 contacts
Coax	2 contacts
Shielded implementation	8, 5, 4 contacts

ODU LAMTAC®

Contacts with lamella technology.

The ODU LAMTAC contact consists of a lathe-turned body in which one or more stamped lamella strips are mounted. The individual bars of the lamella provide numerous contact points which guarantee high contact reliability and optimum conductive properties. The adapted contact force ensures low mating and demating forces, and a long service life with low wear. The mating cycles here are minimum 10,000.

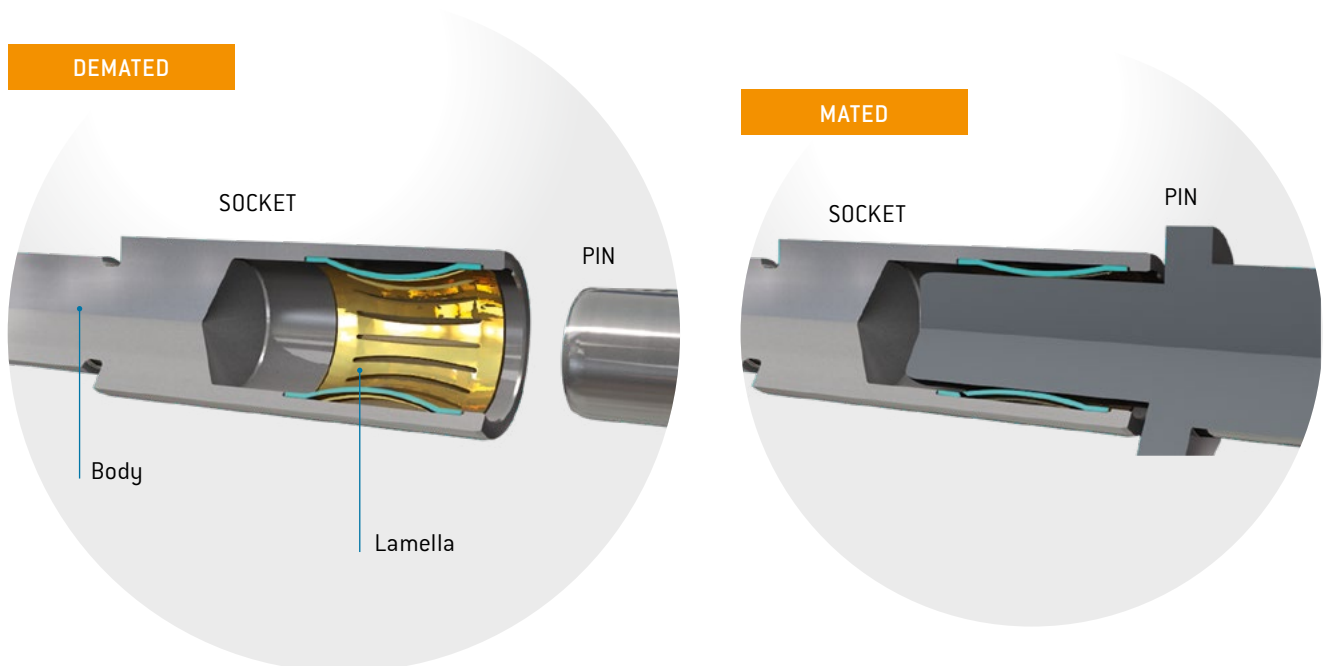

ADVANTAGES

- > 10,000 mating cycles
- High current-carrying capacity – surge current capacity
- Low contact resistances
- Low mating and demating forces
- Secure connection
- High vibration and shock resistance
- Economical alternative to springwire contacts
- Individual contacts upon request

Standard contact principle for:	
High current	2 to 1 contact(s)
High voltage	1 contact
Coax	4 contacts
Shielded implementation	Shielded transmission

ODU TURNTAC®

Contacts in slotted version.

The universal ODU TURNTAC contact system combines the very best contact properties and high quality with economic prices. By means of the optimum guidance and assembly in the ODU-MAC system, the longevity of 10,000 mating cycles and more can be achieved.

The contact principle can even be used in dimensions as tiny as 0.3 mm in diameter. Depending on the variety of slotted contact, the connector systems offers two or four contact areas.

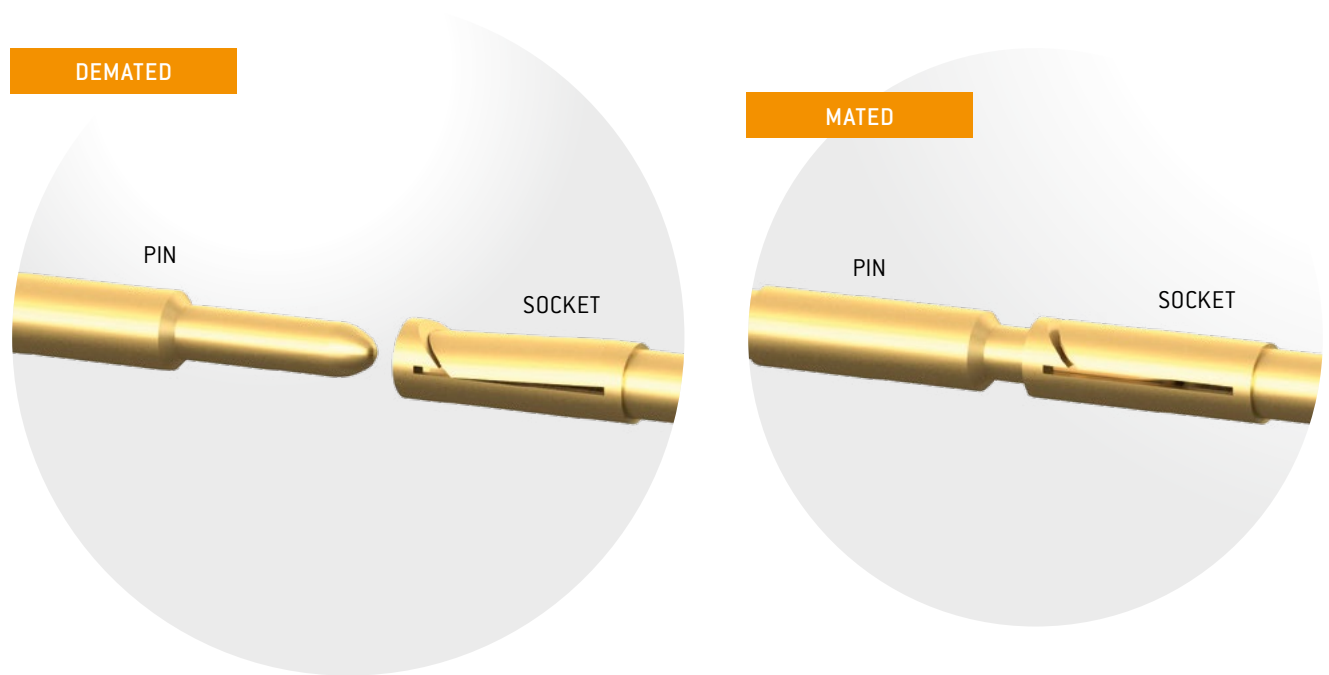

ADVANTAGES

- > 10,000 mating cycles
- Economical solution
- The smallest dimensions are possible
- Individual contacts upon request

Standard contact principle for:

Shielded implementation

Signal contacts

ODU STAMPTAC®

Contacts in stamped version.

Thanks to its economical manufacture, the ODU STAMPTAC is the most affordable alternative for large numbers of units. Available in various coil sizes for processing with hand crimpers and (semi-) automatic stripper crimpers. This reduces the preparation time enormously. This contact is used in the 10 contacts module (see page [106/107](#)).

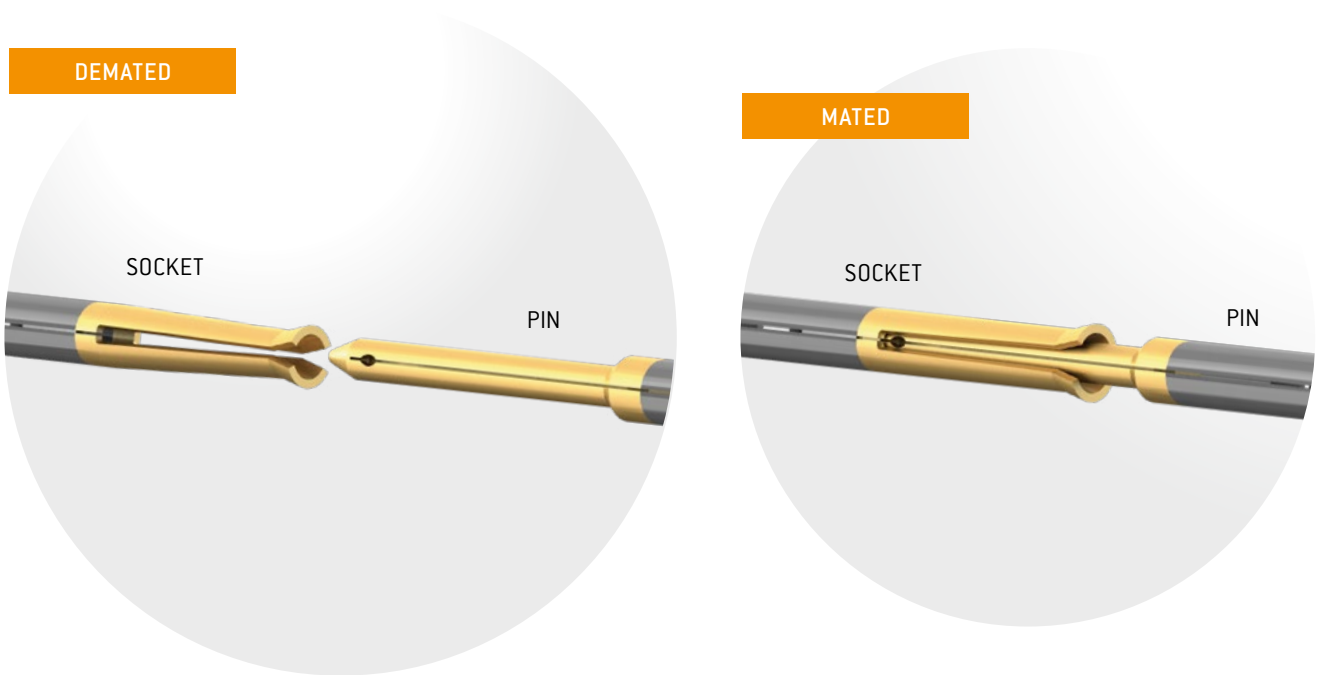

ADVANTAGES

- 5,000 mating cycles
- High quality materials and surfaces with selective plating
- Most affordable alternative for large numbers of units
- Cost-effective processing
- Automatic processing from tape reel possible

Standard contact principle for:	
Signal	10 contacts

CONTACT RETENTION WITH THE CLIP PRINCIPLE (STANDARD)

The adjacent photo shows how the contact is fixed in the insulator. The contact is pushed from the termination area (rear insertion) into the insulator and locked in by a metal clip (barbed hook) snapping behind a flange.

The contacts can be easily removed again at any time with a removal tool.

Compared with permanent connections, crimp technology allows replacement of contacts and easy repair. Voltage values can be increased by leaving contact positions free. Contact assembly can be performed independently of the insulator.

Not all modules are equipped with the clip principle, but removal is possible. The 10-position module does not have a removable contact system.

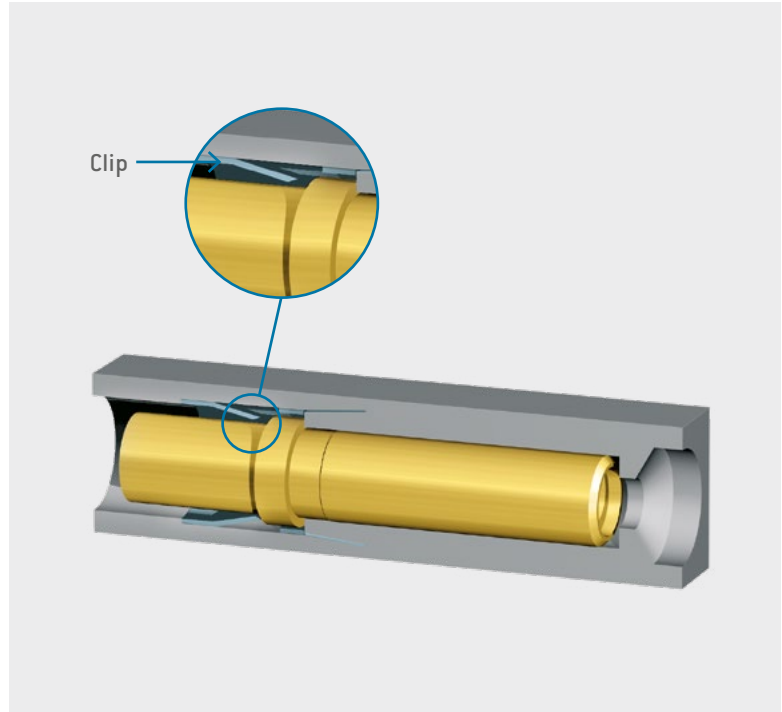

Most of the modules include this fastening technology.



3 mounting lugs for optimal stability.

FOR YOUR NOTES

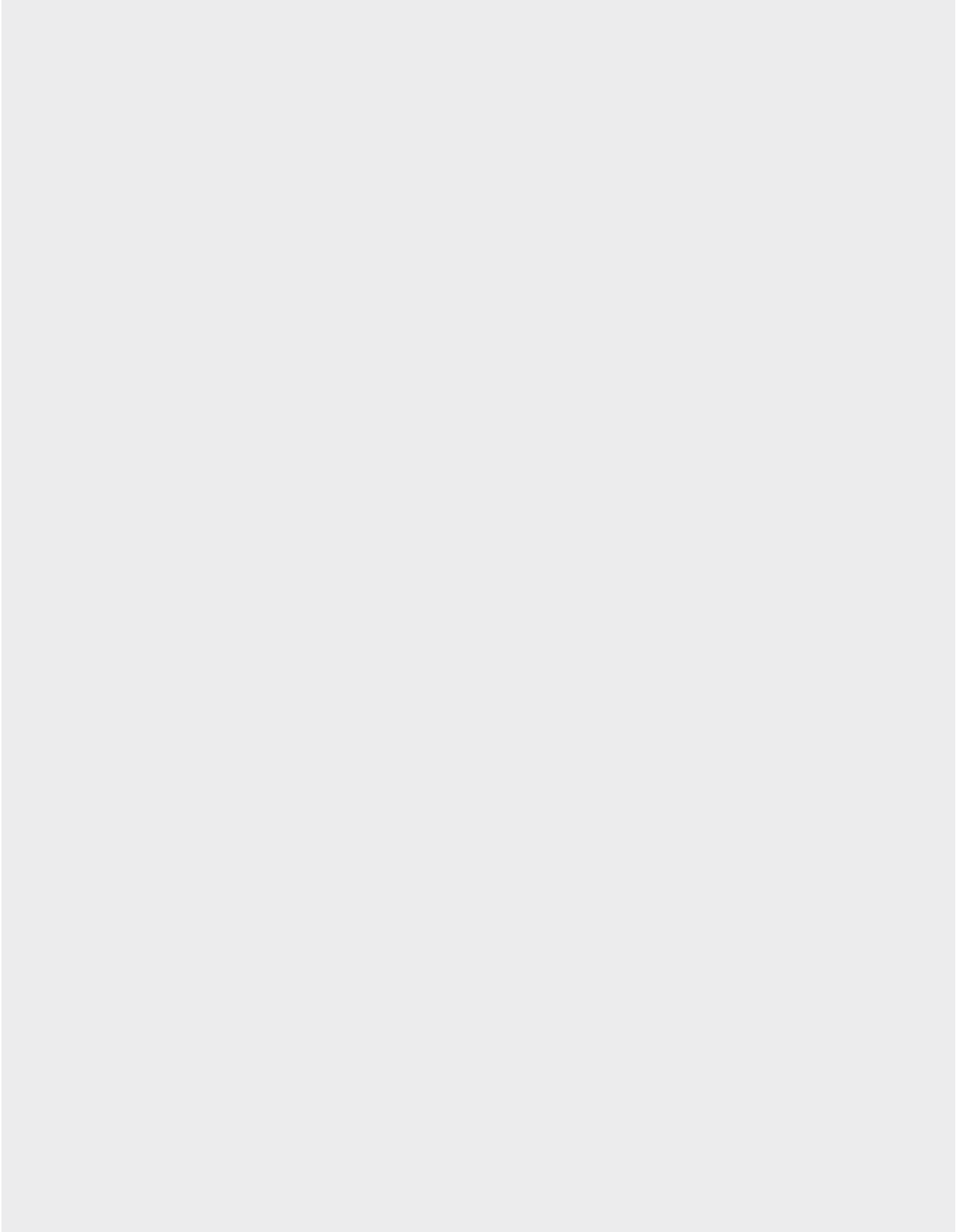

APPLICATION SPECIFIC SOLUTIONS

Problem solvers who think outside the box are required when standard solutions find their limits. ODU offers you just this kind of expert: the ones who focus on your specific requirements. For every development order we get, we not only perform a thorough review study, we intensively involve our customers in the ongoing design process. This guarantees an impressive, custom-fit final result. Our standard connectors are frequently the base for custom modifications.

FOR INDUSTRIAL

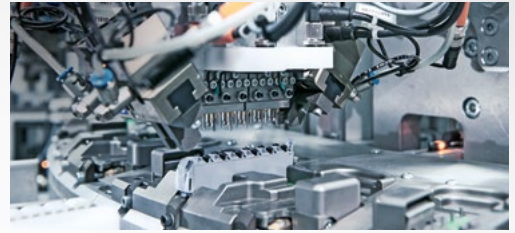

FOR MEDICAL



MONOBLOC INSULATOR

Customers install this insulator block, equipped with standard ODU-MAC contacts, into its own custom housing.



COMPLETE DOCKING UNIT

Three ODU-MAC rows incl. spindle locking are mounted in a special stainless steel frame.

Advantages

- Special floating support with tolerance compensation ± 3 mm

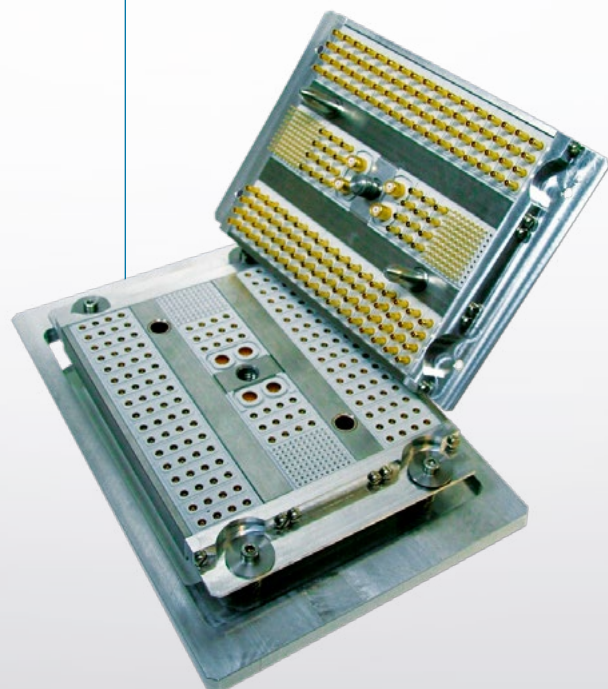

MANUAL MATING

Well-known manufacturers worldwide trust in the ODU-MAC system as a reliable connector between the various patient coils and the MRI device. To help streamline operations, the connector is also available in a version with non-magnetic materials.

Advantages

-  Non-magnetic version, e.g. for MRI application
- Plastic sleeve housing with individual monobloc
- Customized contact configuration possible
- Spindle locking



MANUAL MATING

An insulator developed specific to the application, equipped with coaxial and signal contacts, forms the connector between the MRI device and the individual body coils.

Advantages

- Minimum 50,000 locking cycles
-  Non-magnetic
- 1.3 and 2.8 GHz frequency range
- 50 Ω
- High packing density



ODU-MAC® FOR SPARK WAVE® THERAPY DEVICE

The Spark Wave® therapy device for urogenital treatment applications contains the ODU-MAC modular connector. This ensures a secure connection between the device and the applicator, which sends out bundled sound waves. The sophisticated cable assembly is also provided by ODU.

Advantages

- Extremely easy change of applicator via a fully automatic locking and unlocking function
- Hybrid solution with signals, high voltage and fluids
- System solution including cable assembly





CONFIGURE THE ODU-MAC®.
SIMPLY ONLINE AT WWW.ODU-MAC.COM

ODU-MAC®

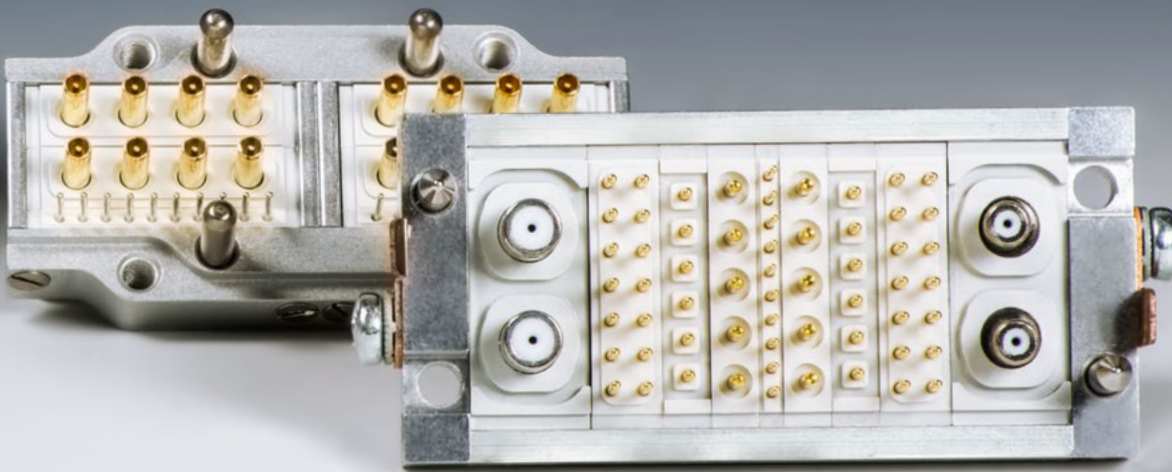

AUTOMATIC DOCKING

Requirements on the complete system	40
ODU-MAC® S (Standard)	42
ODU-MAC® L (Large)	43
ODU-MAC® M+ (Mini)	44
ODU-MAC® P+ (Power)	45
PE transmission, grounding kit	46
ODU-MAC® T (Transverse)	48
ODU-MAC® QCH (Quick Change Head)	49
Strain relief housing	50

SYSTEM REQUIREMENTS AND TOLERANCES

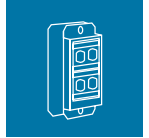

High mating cycles and perfect transfer rates – in order to ensure these for automatic docking over the long term, the docking system must be a design consideration (e.g. centering systems).

Clean and smooth docking is secured by special guiding pins that are designed for the forces which guide the connector. Please note the mechanical requirements behind the design.

MAXIMUM PERMISSIBLE OFFSET + STANDARD GAP MEASURE IN MATED CONDITION (RADIAL PLAY)

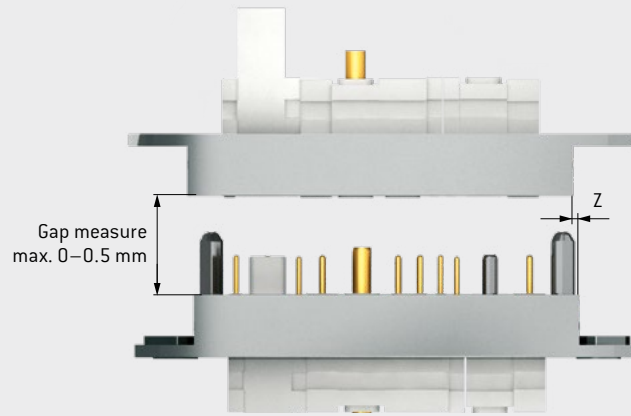
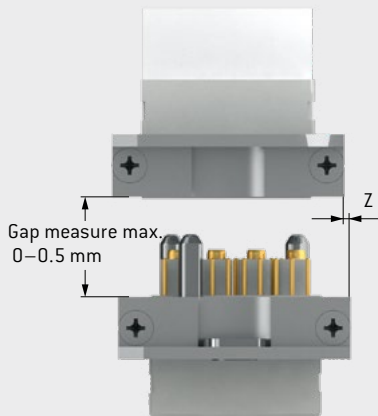

Frame	Tolerance
z	
S	+/- 0.6 mm
L	+/- 1.2 mm
M+	+/- 0.6 mm

Frame	Tolerance
z	
T	On request
P+	+/- 2.5 mm
QCH	+/- 0.6 mm

The maximum permissible gap between socket and pin pieces is 0.5 mm as a standard. Extension with long contact pins is possible.

MAXIMUM PERMISSIBLE ANGLE DEVIATION WHEN MATING

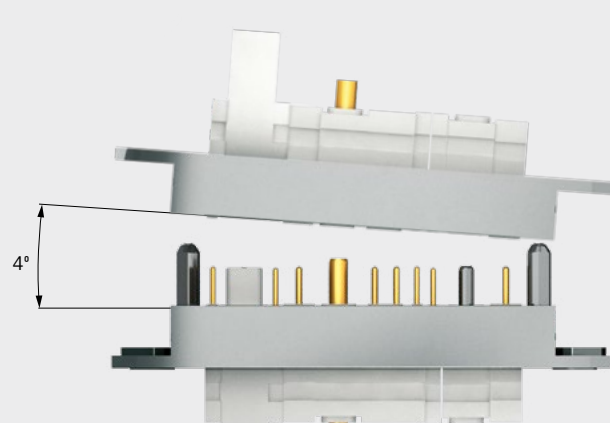
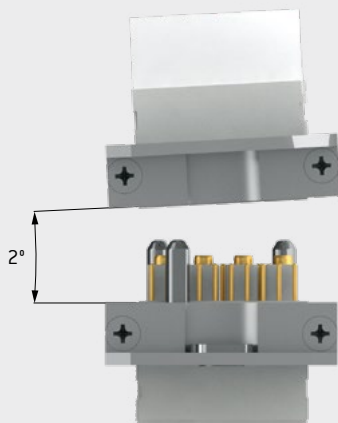

OUR TEAM IS HAPPY TO ANSWER ANY ENQUIRIES YOU MAY HAVE.

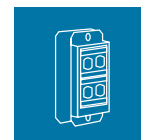

EXAMPLE OF AN S FRAME SYSTEM

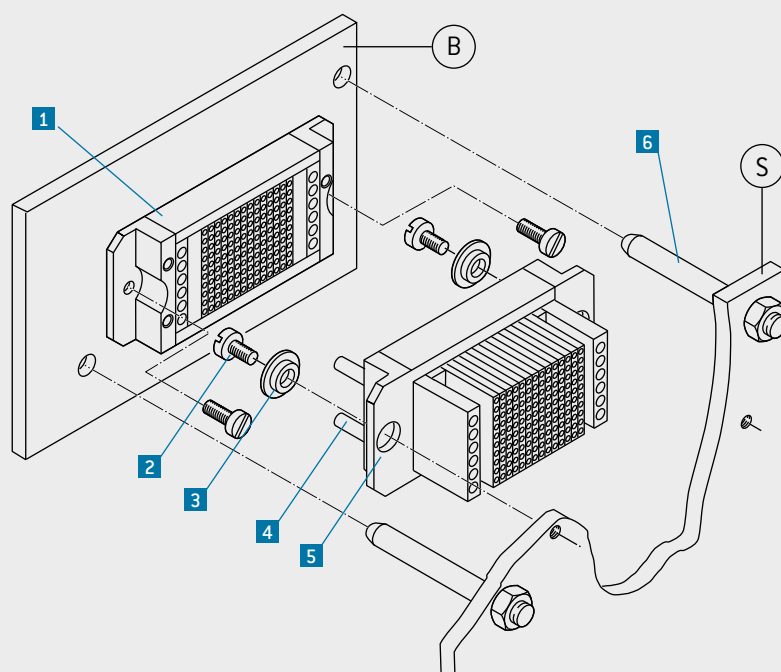

Strain relief for cables/braids must be provided by the customer. Draw your attention to our strain relief housing page 50.

- 1 ODU-MAC® socket piece (fixed)
(screwed tight without play to wall B)
- 2 Fastening screw
- 3 Tolerance compensation in the example of an S frame:
Axial play: 0.2 mm
Radial play: ± 0.6 mm
- 4 Pins for self-centering of ODU-MAC®
- 5 ODU-MAC® pin piece (floating)
(with play via centering socket; screwed tight to wall S)
- 6 Pin for guiding walls B and S
(customer performance)

The values for the connected condition (pin S in B) result from the axial play of the centering sockets.

NOTE: AUTOMATIC DOCKING SYSTEMS

- The pin piece of the ODU-MAC S is to be fixed with the accompanying centering sockets and has mounted floating
- The guiding system of the ODU-MAC requires additional guiding hardware for the system
- The maximum permissible gap between socket and pin pieces is 0.5 mm as standard.
Extension with long contact pins is possible.
- An alignment system (e.g. guide rails, etc.) is necessary to achieve high mating cycles.
The max. permissible alignment error is, for example, with the ODU-MAC S frame, less than ± 0.6 mm radial
- Strain relief for the cables/braids must be provided by the customer or use our strain relief housing see page 50.

FAILURE TO OBSERVE THESE SPECIFICATIONS MAY RESULT IN DAMAGE.

ODU-MAC® S (STANDARD)

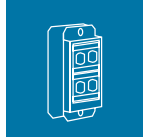

Standard solutions for docking applications.



TECHNICAL DATA

- Tolerance compensation:
Axial play: 0.2 mm
Radial play: +/- 0.6 mm
- Pin piece floating supported
- Minimum 100,000 mating cycles



Non-magnetic version available upon request.

SOCKET FRAME WITH GUIDING HOLE

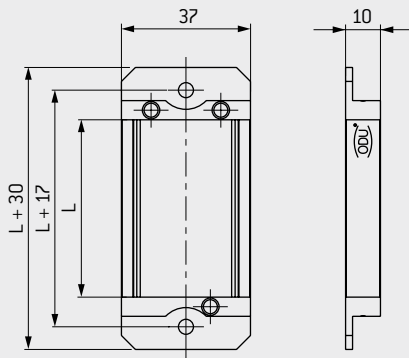

PIN FRAME WITH GUIDING PIN

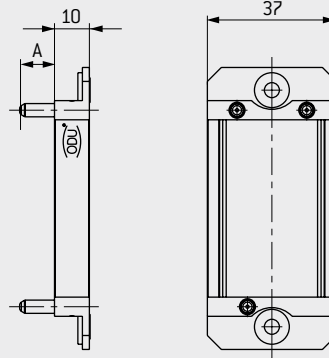

PANEL CUT-OUT

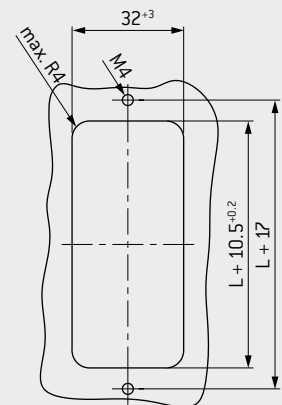

Description	Part number	Dim. A	Note
Pin frame	611.020.0__600.000	10	
Socket frame	610.020.0__600.000		
Pin frame	611.021.0__600.000	12.5	
Socket frame	610.020.0__600.000		
Pin frame	611.025.0__600.000	21	Model for spindle locking
Socket frame	610.020.0__600.000		
Pin frame	611.050.0__600.000	10	With labelling
Socket frame	610.050.0__600.000		

L = Number of units × 2.54

__ = Here please register number of desired units (03 to 60, above 61 on request)

ODU-MAC® L (LARGE)

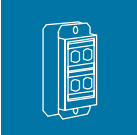

Frame with higher tolerance compensation and reinforced guiding bushes as well as extended guiding pins.



TECHNICAL DATA

- Tolerance compensation:
Axial play: 0.4 mm
Radial play: +/- 1.2 mm
- Double-sided floating supported
- Minimum 100,000 mating cycles



Non-magnetic version available upon request.

AUTOMATIC DOCKING

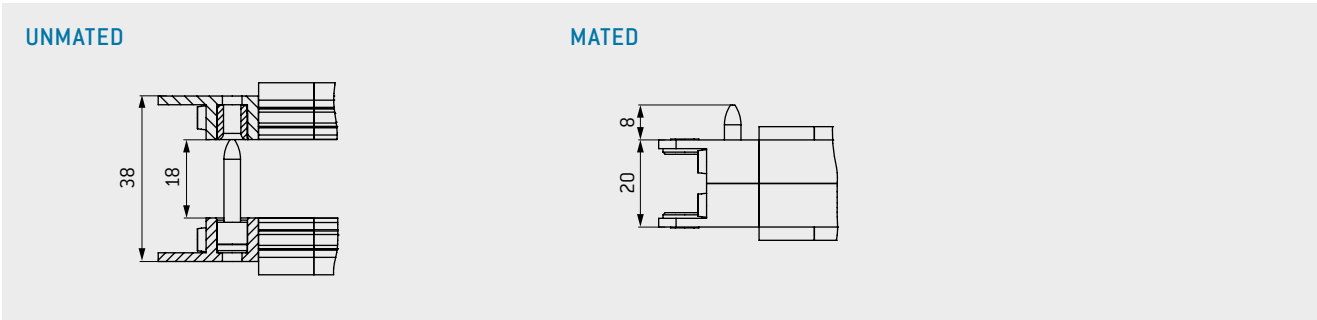
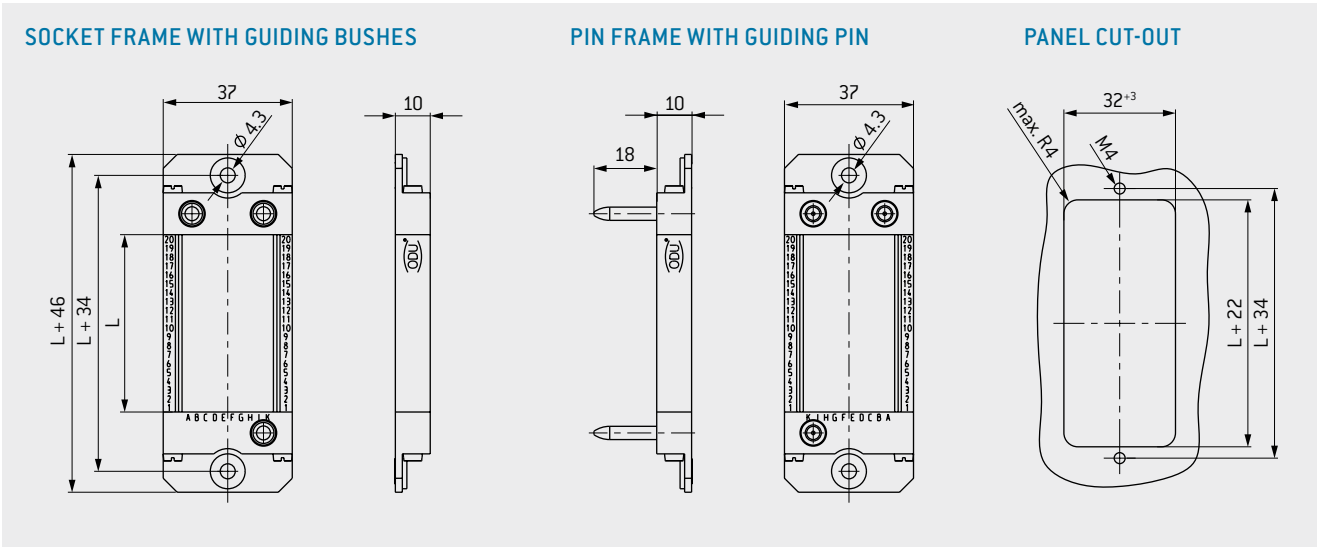

Description	Part number
Pin frame	611.009.0__600.000
Socket frame	610.009.0__600.000

L = Number of units × 2.54
 __ = Here please register number of desired units
 (03 to 60, above 61 on request)

ODU-MAC® M+ (MINI)

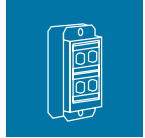

Compact design with minimal space requirements and optional PE transmission.



TECHNICAL DATA

- Tolerance compensation:
Axial play: 0.4 mm
Radial play: ± 0.6 mm
- Double-sided floating supported
- Minimum 100,000 mating cycles
- Optional PE transmission see page [46](#)



Non-magnetic version available upon request.

SOCKET FRAME WITH GUIDING HOLE

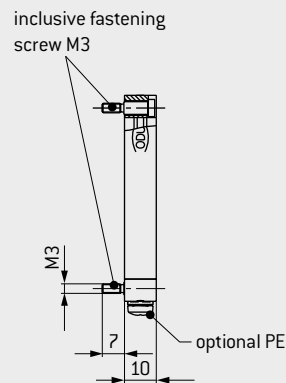
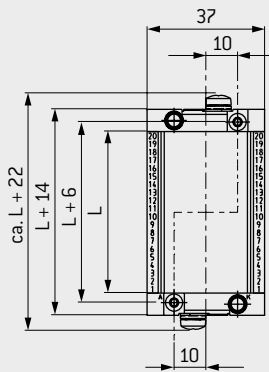

PANEL CUT-OUT

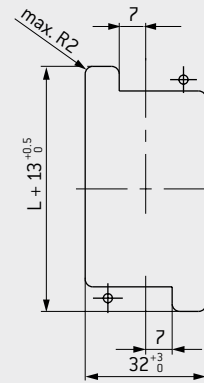

PIN FRAME WITH GUIDING PIN

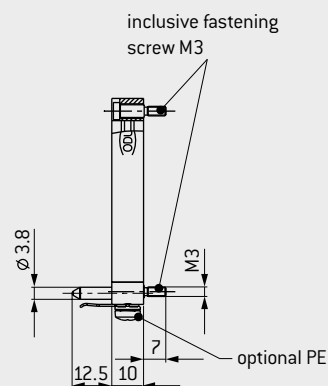
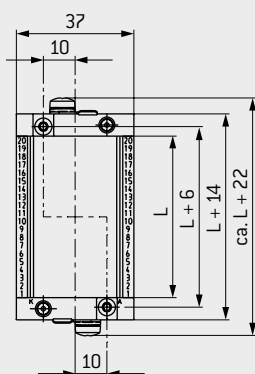

PANEL CUT-OUT

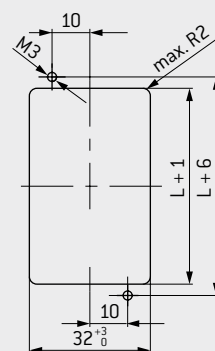

Description	Part number
Pin frame	611.716.0__600.000
Socket frame	610.716.0__600.000

L = Number of units \times 2.54

__ = Here please register number of desired units
(03 to 60, above 61 on request)

NOT COMPATIBLE WITH ODU-MAC M FRAME.

ODU-MAC® P+ (POWER)

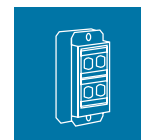

The frame for highest requirements by a reinforced frame design.

High tolerance compensation ± 2.5 mm.



TECHNICAL DATA

- Tolerance compensation:
Axial play: 1 mm
Radial play: ± 2.5 mm
- Double-sided floating supported
- Advisable for modules
with contact diameter > 5 mm
and frame length > 40 units (depending on configuration)
- Contact diameter > 8 mm: this frame has to be used
- Minimum 100,000 mating cycles
- Optional PE transmission see page [47](#)



Non-magnetic version available upon request.

SOCKET FRAME WITH GUIDING BUSHES

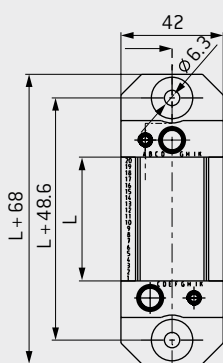

PIN FRAME WITH GUIDING PIN

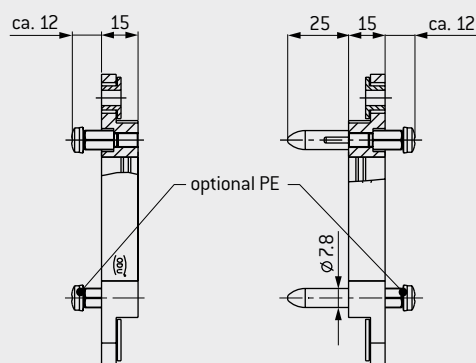

PANEL CUT-OUT

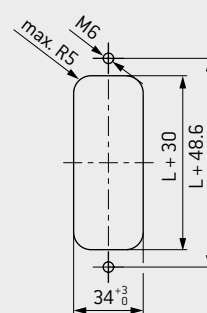

Description	Part number
Pin frame	611.730.0 __.600.000
Socket frame	610.730.0 __.600.000

L = Number of units $\times 2.54$

__ = Here please register number of desired units
(05 to 60 in steps of 5, above 61 on request)

ODU-MAC P+ FRAME WITHOUT OPTIONAL PE TRANSMISSION BACKWARDS COMPATIBLE WITH ODU-MAC P FRAME.

PE TRANSMISSION FOR ODU-MAC M+(MINI)

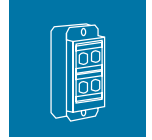

GROUNDING KIT FOR M+ SOCKET FRAME



TECHNICAL DATA

- Tolerance compensation:
Axial play: 0.4 mm
Radial play: +/- 0.6 mm
- Minimum 100,000 mating cycles
- Double-sided version
- Surface: nickel-plated



Non-magnetic version available upon request.

GROUNDING KIT MOUNTED



Part number	Connection threads
190.270.001.000.000	M4

Max. 6 mm² lug connection for PE transmission.

GROUNDING KIT FOR M+ PIN FRAME

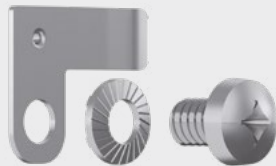

TECHNICAL DATA

- Tolerance compensation:
Axial play: 0.4 mm
Radial play: +/- 0.6 mm
- Minimum 100,000 mating cycles
- Double-sided version
- Surface: nickel-plated



Non-magnetic version available upon request.

GROUNDING KIT MOUNTED

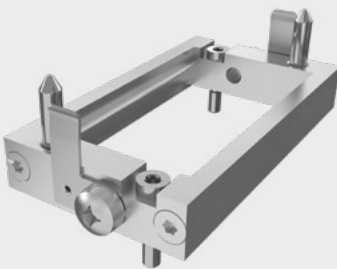

Part number	Connection threads
190.270.002.000.000	M4

Max. 6 mm² lug connection for PE transmission.

CONTACT RESISTANCE COMPLIANT WITH < 0.1 Ω NORM.

PE TRANSMISSION FOR ODU-MAC P+ (POWER)

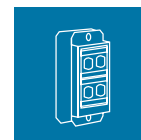

GROUNDING KIT FOR P+ SOCKET FRAME

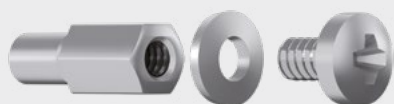

TECHNICAL DATA

- Tolerance compensation:
Axial play: 1 mm
Radial play: +/- 2.5 mm
- Minimum 100,000 mating cycles
- Double-sided version
- Surface: Ag



Non-magnetic version available upon request.

GROUNDING KIT MOUNTED

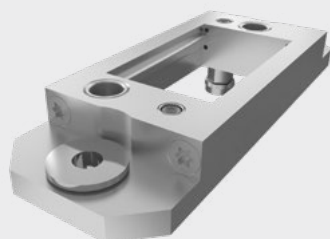

Part number	Connection threads
174.100.100.201.100	M5

Max. 10 mm² lug connection for PE transmission.

GROUNDING KIT FOR P+ PIN FRAME

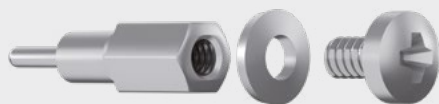

TECHNICAL DATA

- Tolerance compensation:
Axial play: 1 mm
Radial play: +/- 2.5 mm
- Minimum 100,000 mating cycles
- Double-sided version
- Surface: Ag



Non-magnetic version available upon request.

GROUNDING KIT MOUNTED

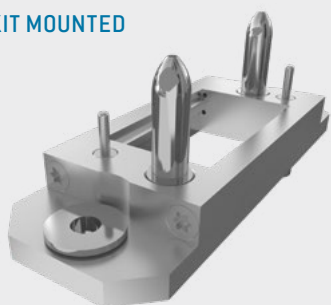

Part number	Connection threads
180.100.000.301.100	M5

Max. 10 mm² lug connection for PE transmission.

CONTACT RESISTANCE COMPLIANT WITH < 0.1 Ω NORM.

ODU-MAC® T (TRANSVERSE)

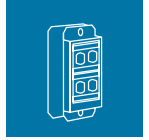

Transverse frame, for when a low installation height is required.

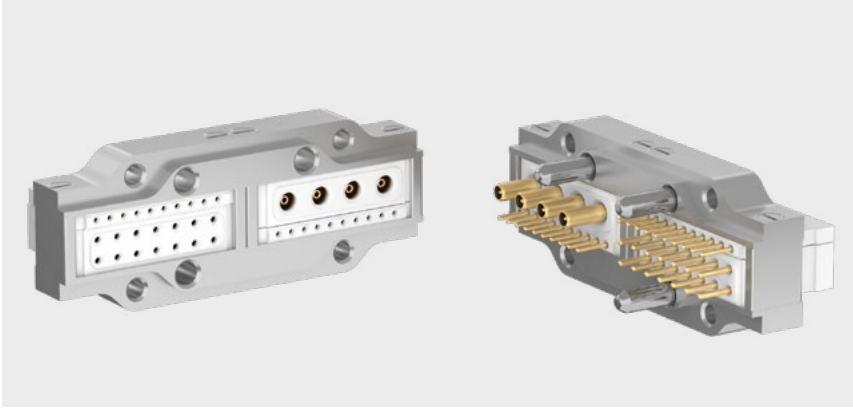

TECHNICAL DATA

- Installation even in housing solution

These models are available on request. Technical specifications have to be clarified in detail.



Standard non-magnetic.

SOCKET FRAME WITH GUIDING HOLE

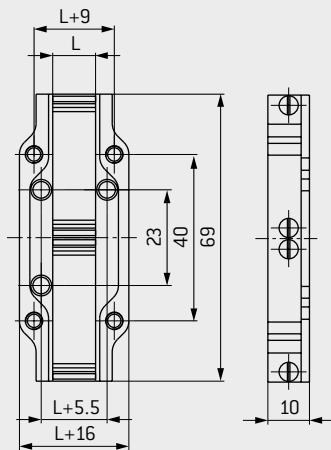

PIN FRAME WITH GUIDING PIN

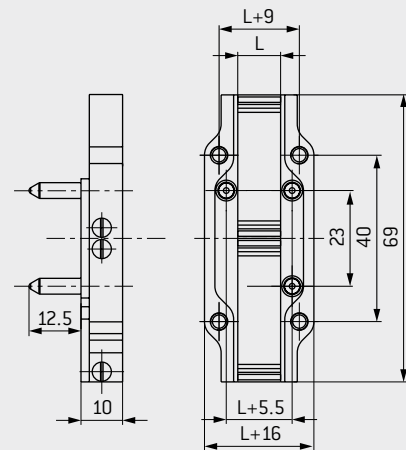

Part number Pin frame	Part number Socket frame	Dim. L mm	Units
611.055.029.303.600	610.055.029.103.600	7.62	3 × 2
611.055.029.304.600	610.055.029.104.600	10.16	4 × 2
611.055.029.305.600	610.055.029.105.600	12.7	5 × 2
611.055.029.306.600	610.055.029.106.600	15.24	6 × 2
611.055.029.307.600	610.055.029.107.600	17.78	7 × 2
611.055.029.308.600	610.055.029.108.600	20.32	8 × 2
611.055.029.309.600	610.055.029.109.600	22.86	9 × 2
611.055.029.310.600	610.055.029.110.600	25.4	10 × 2

PANEL CUT-OUT

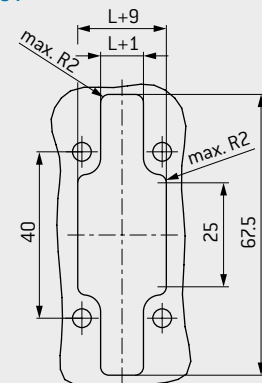

ODU-MAC® QCH (QUICK CHANGE HEAD)

Frames for the highest cycle requirements (connector saver) and with a low maintenance downtime, due replaceable parts.

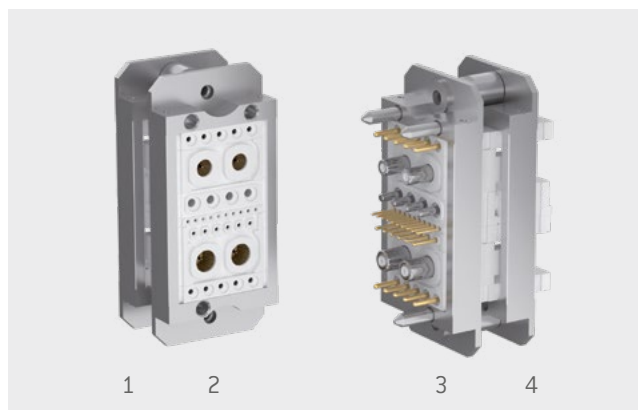
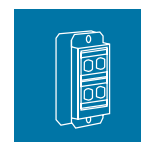

TECHNICAL DATA

- Tolerance compensation:
Axial play: 0.2 mm
Radial play: +/- 0.6 mm
- Pin piece floating supported
- Unlimited number of mating cycles (min. 100,000 mating cycles)
- Replacement of the interchange parts without assembly effort

These models are available on request.

Technical specifications have to be clarified in detail.



Non-magnetic version available upon request.

MOUNTING WALL BACK

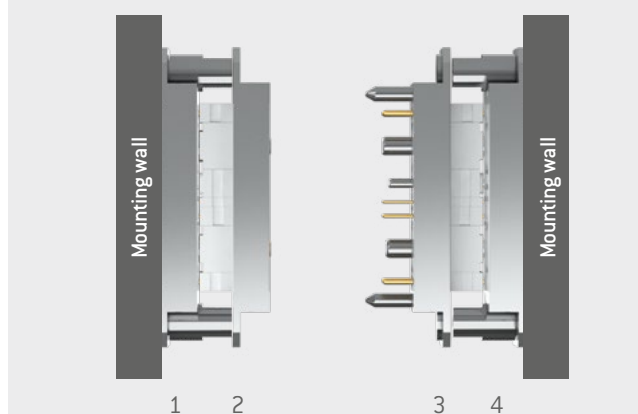

MOUNTING WALL CENTRAL – FOR WALL THICKNESS 10 mm

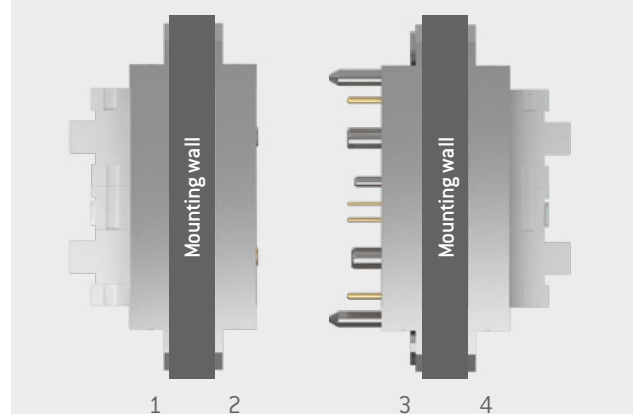

Description	Part number
Part 1: Base part incl. distance piece	610.026.0 __.600.000
Part 2: Socket frame – interchange part	610.020.0 __.600.000
Part 3: Pin frame – interchange part	611.021.0 __.600.000
Part 4: Base part incl. distance piece	610.026.0 __.600.000
Distance piece as a spare part	610.026.201.304.000

Description	Part number
Part 1: Base part	610.027.0 __.600.000
Part 2: Socket frame – interchange part	610.020.0 __.600.000
Part 3: Pin frame – interchange part	611.021.0 __.600.000
Part 4: Base part	611.027.0 __.600.000

The quick change head (connector saver) consists of 4 frames. Pin and socket frames are disconnected or connected when disconnecting or connecting between the second and third frame.

Pieces 1 and 2 or 3 and 4 always remain together.

In the event of damage or wear to the contacts, both replacement parts 2 and 3 are disconnected from pieces 1 and 4 and can be quickly and easily replaced with the new replacement parts without time spent on assembly. The connection is ready to use again within a matter of seconds.

FRAMES FOR THE QUICK CHANGE HEAD SYSTEM

The standard ODU-MAC S docking frames can be used for the connector saver. ODU-MAC L and P+ docking frames upon request. (M+ frame is not possible).

MODULES AND CONTACTS FOR THE QUICK CHANGE HEAD SYSTEM

All modules with depths not exceeding 19 mm can be used in the connector saver system. PCB contacts are installed in pieces 2 and 3. All socket contacts (crimp and PCB termination) suitable for pieces 2 and 3 can be used in pieces 1 and 4.

ODU-MAC® SILVER-LINE STRAIN RELIEF HOUSING

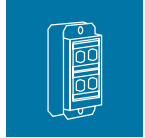

The accessories for docking solutions.



Graphic shows optional cable glamp, it is not automatically in the scope of delivery included.

APPLICATION EXAMPLE

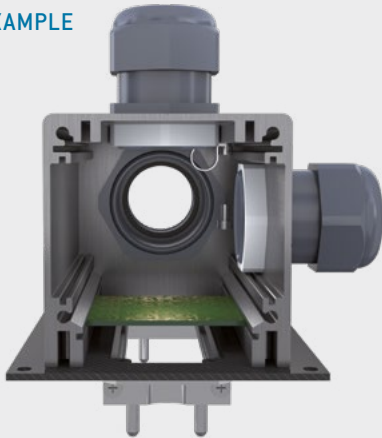

Graphic shows optional cable glamp, it is not automatically in the scope of delivery included. Additional M32 cable clamps can be placed by the customer.

TECHNICAL DATA

- Material: aluminium
- Operating temperature: $-40\text{ }^{\circ}\text{C}$ to $+125\text{ }^{\circ}\text{C}$
- Protection class¹ can be adjusted individually
- Cable clamps, see page [83](#)
- Locknut for cable clamp see page [84](#)

CHARACTERISTICS

- Resistant and compact
- Protection of the termination area
- Individual strain-relief variations, cable entries as well as grounding connections
- Suitable for all ODU-MAC docking frames
- 6 standard lengths, compatible with all ODU-MAC docking frame varieties (further lengths available on request)
- Optional fixing of the PCBs and components in the protected interior
- ODU logo included as a standard; customer logo can also be delivered upon request

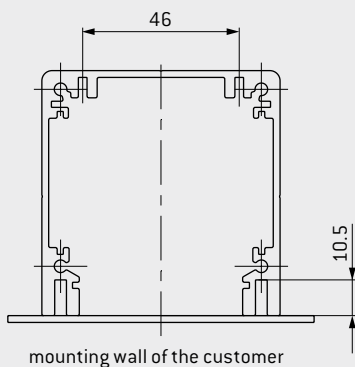

¹ A higher protection class is possible for additional sealing of the housing.

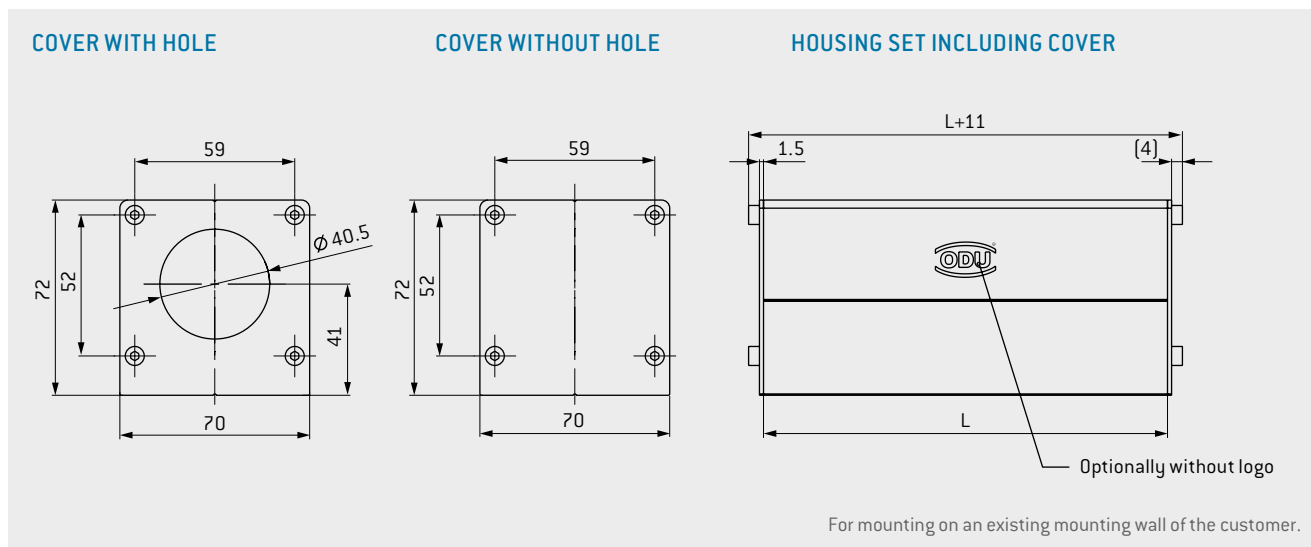
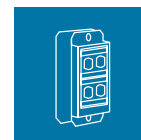

Part number 2 × cover without hole	Part number 1 × cover with/1 × cover without hole	Part number 2 × cover with hole	Units 2.54 mm	Dim. L mm
616.010.100.600.000	616.010.114.600.000	616.010.144.600.000	10	97
616.020.100.600.000	616.020.114.600.000	616.020.144.600.000	20	123
616.030.100.600.000	616.030.114.600.000	616.030.144.600.000	30	149
616.040.100.600.000	616.040.114.600.000	616.040.144.600.000	40	174
616.050.100.600.000	616.050.114.600.000	616.050.144.600.000	50	199
616.060.100.600.000	616.060.114.600.000	616.060.144.600.000	60	224

The set comprises a housing profile including 2 covers and corresponding fastening screws for assembly of the included cover. Fastening material for an existing mounting wall of the customer is not included in the scope of delivery.



CONFIGURE THE ODU-MAC®.
SIMPLY ONLINE AT WWW.ODU-MAC.COM

ODU-MAC®



MANUAL MATING

ODU-MAC® ZERO/Snap-In locking	<u>54</u>
Spindle locking	<u>56</u>
Metal housing	<u>58</u>
Plastic housing	<u>62</u>
Transverse locking, plastic housing	<u>65</u>
Lever locking, metal housing	<u>70</u>
Housing with IP 68/IP 69/EMC	<u>78</u>
Frame for housing	<u>82</u>
Accessories	<u>83</u>
Coding possibilities	<u>86</u>
Flexible circular connectors with ODU-MAC® inserts	<u>92</u>



ODU-MAC® ZERO

Connector housing for mounting on the cable with different cable entries.
ODU-MAC rail for installing the insulator is already integrated in the housing.

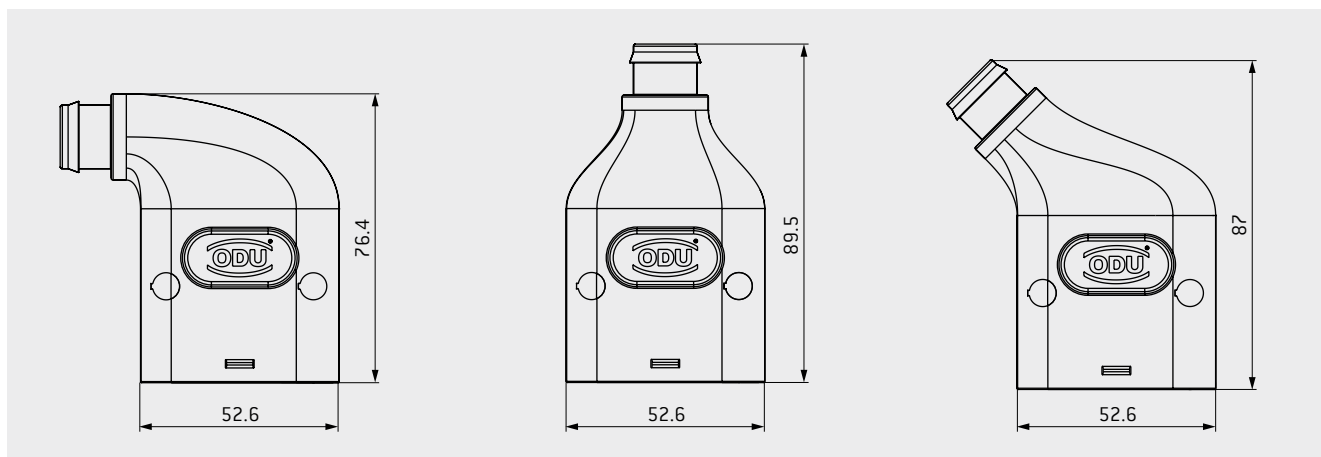

SNAP-IN LOCKING (BREAK-AWAY FUNCTION)



Part number	Cable exit	Size	Units ¹ 2.54 mm
656.560.004.001.000	90°	ZERO	
656.560.006.001.000	0°	ZERO	
656.560.002.001.000	45°	ZERO	

TECHNICAL DATA

Color of housing	White black/gray on request
Locking cycles	60,000
Material	PC Lexan (PEI on request)
Protection class ²	IP 54
Operating temperature	-40 °C to +125 °C
Cable-Ø	8 to 14.5 mm

The cable bend relief must be ordered separately
see page [85](#).



SUITABLE MODULES ARE MARKED.

¹ The frame is already permanently integrated and consists of nine units. ² IEC 60529:2013 (VDE 0470-1:2014).

RECEPTACLE



For integration in the device.

SNAP-IN LOCKING (BREAK-AWAY FUNCTION)

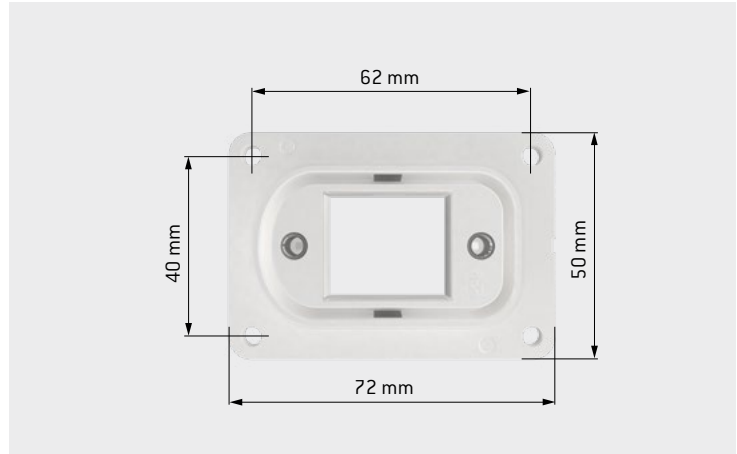

PANEL CUT-OUT

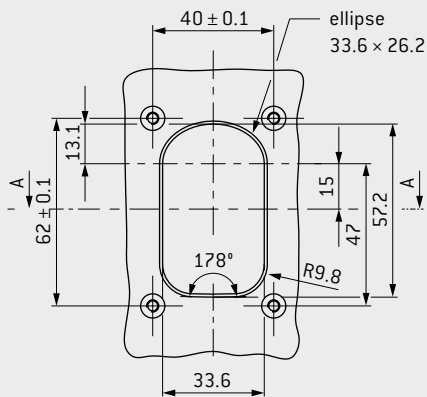

TECHNICAL DATA

Color of housing	White black/gray on request
Locking cycles	60,000
Material	PC Lexan (PEI on request)
Protection class ¹	IP 54
Operating temperature	-40 °C to +125 °C

Part number	Units ²
656.560.001.001.000	2.54 mm 9 Units

MOUNTING FROM BELOW

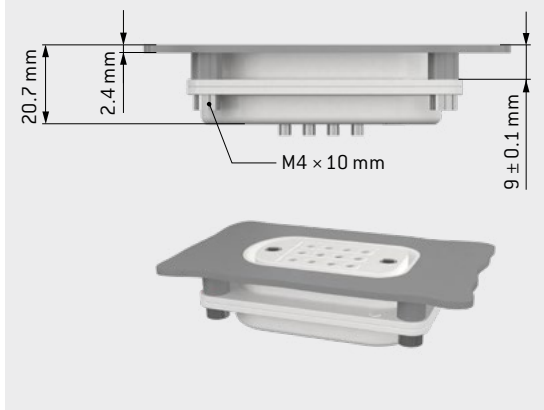

MOUNTING FROM ABOVE

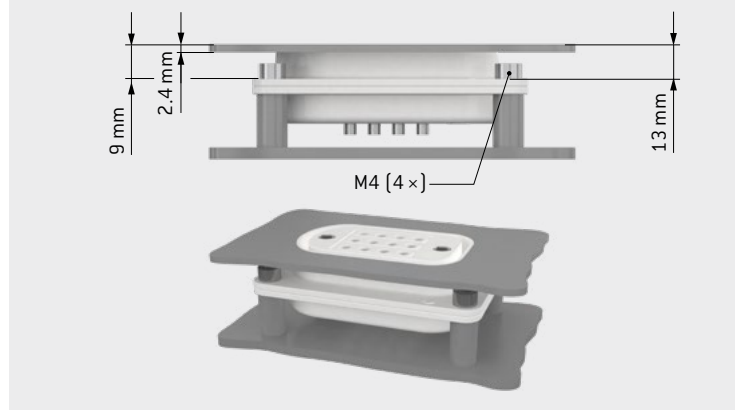

MAXIMUM MATING SECURITY THROUGH MECHANICAL CODING (D-SHAPE) AND EASY HANDLING.

¹ IEC 60529:2013 (VDE 0470-1:2014). ² The frame is already permanently integrated and consists of nine units.

SPINDLE LOCKING

Module for installation in ODU-MAC® frames for housings. Quick-action locking system with 30,000 locking cycles. Simple replacement of the front (spindle exchange set) enables further mating cycles of the complete system.



VERSION 1: FOR SOCKETS IN BULKHEAD MOUNTED OR SURFACE MOUNTED HOUSING AND PINS IN CABLE HOOD

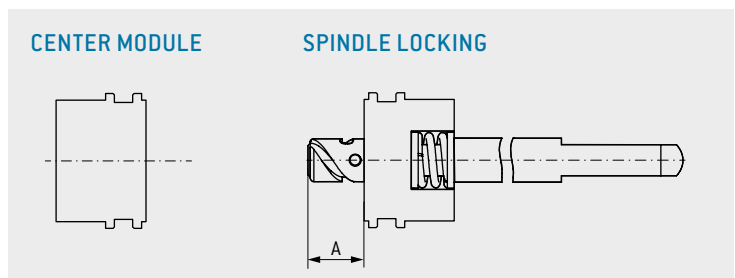
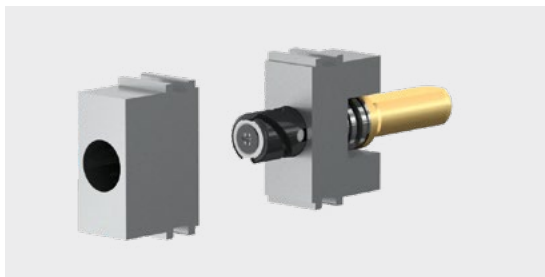

Size	Part number Center module for bulkhead mounted and surface mounted housing	Part number Spindle locking for cable hood	Angle of rotation	Dim. A mm
2 (52 mm high)	614.090.001.304.000	615.091.003.200.000	180°	12
2 (72 mm high)	614.090.001.304.000	615.091.001.200.000	180°	12
3/4	614.090.001.304.000	615.092.021.200.003	360°	21.5
4/XXL	614.090.001.304.000	615.093.021.200.003	360°	21.5

- Max. locking cycles 30,000¹
- Space requirement 5 units (5 × 2.54 mm)
- Further spindle geometries on request
- Spindle with coding function
see page 90

¹ 30,000 cycles depending on mating force of the used modules.



VERSION 2: FOR PINS IN BULKHEAD MOUNTED OR SURFACE MOUNTED HOUSING AND SOCKETS IN CABLE HOOD (REVERSED GENDER)

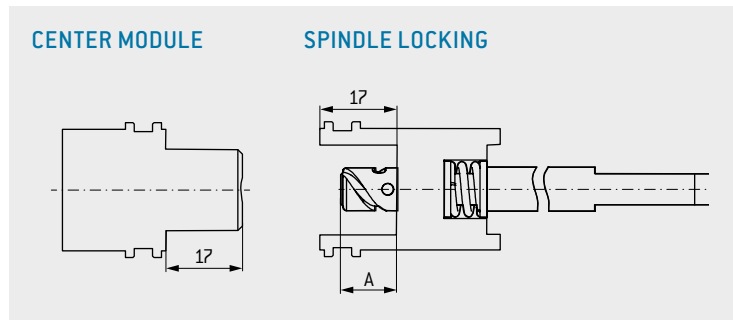
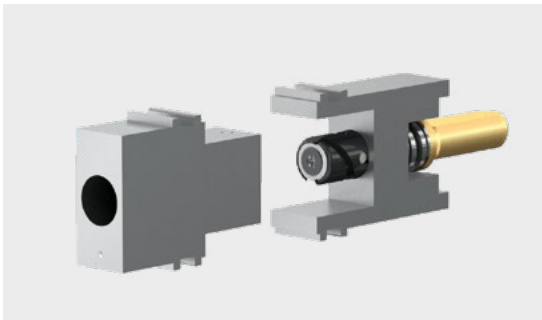

Size	Part number Center module for bulkhead mounted and surface mounted housing	Part number Spindle locking for cable hood	Angle of rotation	Dim. A mm
2 (52 mm hoch)	614.090.002.304.000	615.091.004.200.000	180°	12
2 (72 mm hoch)	614.090.002.304.000	615.091.002.200.000	180°	12
3/4	614.090.002.304.000	615.092.022.200.003	360°	21.5
4 /XXL	614.090.002.304.000	615.093.022.200.003	360°	21.5

- Max. locking cycles 30,000¹
- Space requirement 5 units (5 × 2.54 mm)
- Further spindle geometries on request
- Spindle with coding function available upon request.

REPLACEMENT SPINDLE SET FOR VERSION 1 AND 2



Part number spindle exchange set	Angle of rotation	Dim. A mm
615.090.104.249.000	180°	12
615.090.104.249.003	360°	21.5

Replacement set for easy and rapid replacement of spindle screw from the front.

¹ 30,000 cycles depending on mating force of the used modules.

METAL CABLE HOOD



Connector housing for assembly on the cable with side cable entry.

SPINDLE LOCKING



A GRAY MODEL (STANDARD)

B WHITE MODEL

C WHITE MODEL WITH BLACK KNOB

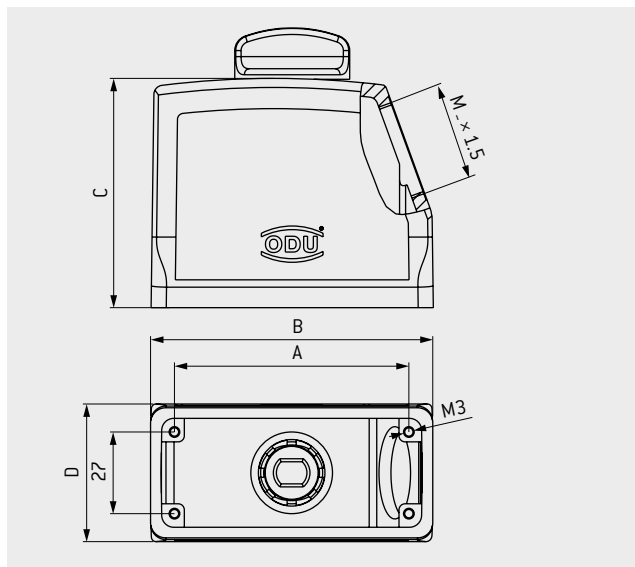

TECHNICAL DATA

Color of housing	Gray (standard, similar to RAL 7001) or white (similar RAL 9010)
Material	Aluminium die casting
Protection class ¹	IP 50 or IP 65
Operating temperature	−40 °C to +125 °C
Cable clamp	see page 83
Number of locking cycles	see page 56
Adapter	for PG clamp see page 84

Size	IP	Part number A Color of housing gray/ spindle knob black	Part number B Color of housing white/ spindle knob white	Part number C Color of housing white/ spindle knob black	Dim. A mm	Dim. B mm	Dim. C mm	Dim. D mm	Dim. M Cable entry	Part number protective cover gray (see page 77)
2	50	613.091.513.644.208	613.091.513.653.203	–	57	73	52	43	M25	491.097613.644.000
		613.091.514.644.208	613.091.514.653.203	613.091.514.653.208	57	73	72	43		
	65	613.091.574.644.008	–	–	57	73	72	43		
3	50	613.092.514.644.208	613.092.514.653.203	613.092.514.653.208	77.5	93.3	76	45.5	M32	492.097613.644.000
	65	613.092.574.644.008	–	–	77.5	93.3	76	45.5		
4	50	613.093.514.644.208	613.093.514.653.203	613.093.514.653.208	104	120	76	45.5	M40	493.097613.644.000
		On request	On request	613.093.515.653.008	104	120	76	45.5		
	65	613.093.574.644.008	–	–	104	120	76	45.5		
		613.093.575.644.008	–	–	104	120	76	45.5		

¹ IEC 60529:2013 (VDE 0470-1:2014) [Depends on the cable clamp(s) and spindle type used].

CABLE HOOD XXL



Connector housing for assembly on the cable. With expanded assembly space and side M50 cable entry.

SPINDLE LOCKING



A GRAY MODEL

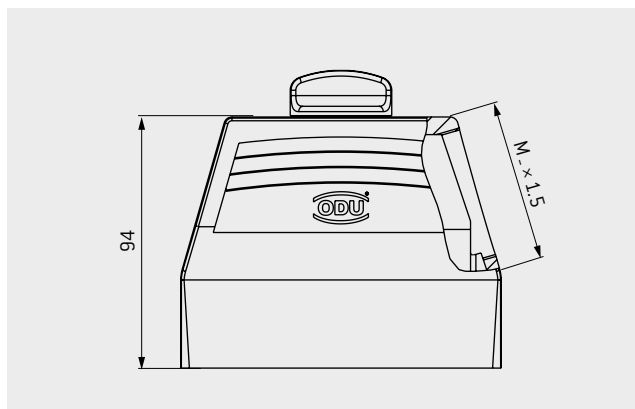

TECHNICAL DATA

Color of housing	Gray (similar to RAL 7001) white on request
Material	Aluminium die casting
Protection class ¹	IP 50 or IP 65
Operating temperature	-40 °C to +125 °C
Cable clamp	see page 83
Number of locking cycles	see page 56

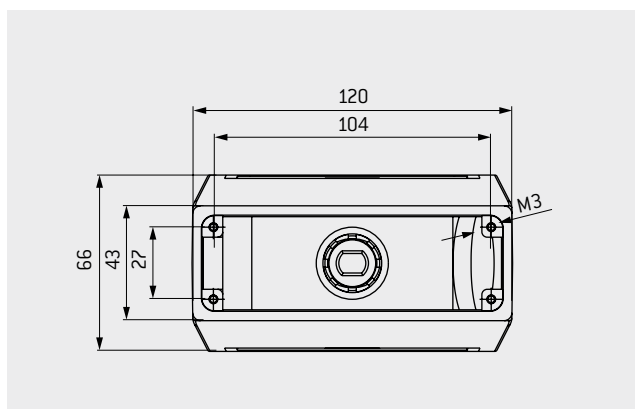

Size	IP	Part number	Dim. M	Part number protective cover
		Color of housing gray/spindle knob black	Cable entry	[see page ??]
4	50	613.093.516.644.208	M50	493.097.613.644.000
4	65	613.093.576.644.008	M50	493.097.613.644.000

¹ IEC 60529:2013 (VDE 0470-1:2014) [Depends on the cable clamp(s) and spindle type used].

METAL BULKHEAD MOUNTED HOUSING



For mounting on the device.

SPINDLE LOCKING

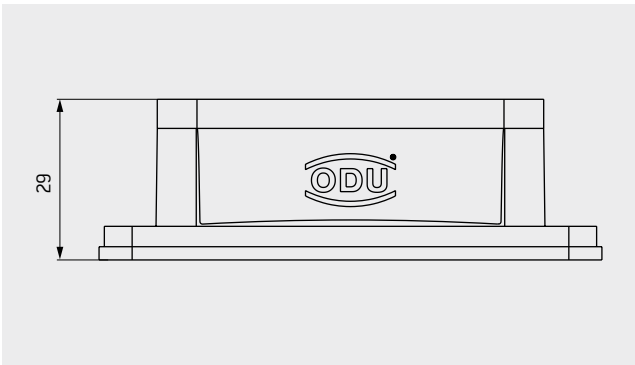

TECHNICAL DATA

Color of housing	Gray (standard, similar to RAL 7001) or white (similar to RAL 9010)
Material	Aluminium die casting
Protection class ¹	IP 65
Operating temperature	-40 °C to +125 °C (short duration) -40 °C to +85 °C (operating)
Sealing	NBR; sealing material FKM on request (higher temperature range)

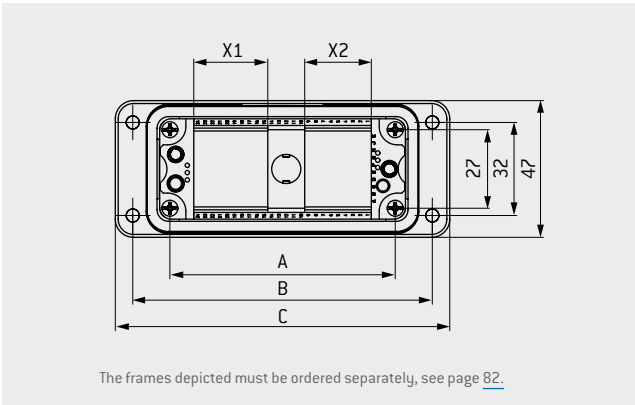

PANEL CUT-OUT

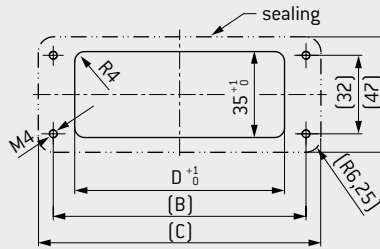

The frames depicted must be ordered separately, see page 82.

Size	Part number A	Part number B	Dim. A	Dim. B	Dim. C	Dim. D Panel cut-out	X1	X2
	Color of housing gray	Color of housing white	mm	mm	mm	mm	Units 2.54 mm	Units 2.54 mm
2	612.091.010.644.000	612.091.010.653.000	57	83	95	65.2	5	6
3	612.092.010.644.000	612.092.010.653.000	77.5	103	115	85.5	9	10
4	612.093.010.644.000	612.093.010.653.000	104	130	143	112.2	14	15

¹ IEC 60529:2013 (VDE 0470-1:2014) [Depends on the spindle type used].

METAL SURFACE MOUNTED HOUSING



For surface mounting on your device/wall with two side cable entries.

SPINDLE LOCKING

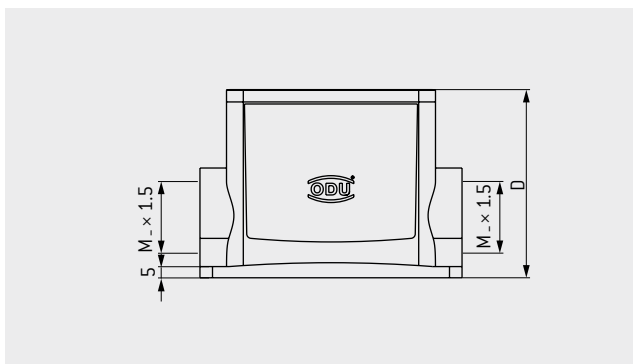

TECHNICAL DATA

Color of housing	Gray (standard, similar to ral 7001) white on request
Material	Aluminium die casting
Protection class ¹	IP 65
Operating temperature	-40 °C to +125 °C (short duration) -40 °C to +85 °C (operating)
Sealing	NBR; sealing material FKM on request (higher temperature range)
Cable clamp	See page 83
Adapter	for PG clamp See page 84

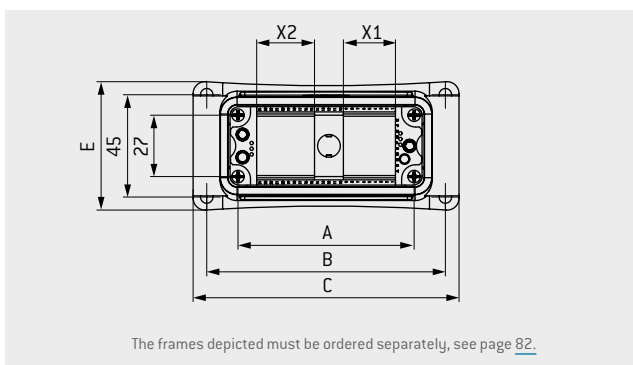

Size	Part number A	Part number B	Dim. A	Dim. B	Dim. C	Dim. D	Dim. E	X1	X2	Dim. M
	Color of housing gray	Color of housing white	mm	mm	mm	mm	mm	Units 2.54 mm	Units 2.54 mm	Cable entry
2	612.091.025.644.102	612.091.025.653.102	57	82	92.5	74	55.5	5	6	M32
3	612.092.025.644.102	612.092.025.653.102	77.5	105	117	84	56.5	9	10	M32
4	612.093.025.644.102	612.093.025.653.102	104	132	144	84	57.5	14	15	M32

¹ IEC 60529:2013 (VDE 0470-1:2014) [Depends on the cable clamp(s) and spindle type used].

PLASTIC CABLE HOOD



Plastic cable hood for assembly on cable and side cable entry.

SPINDLE LOCKING

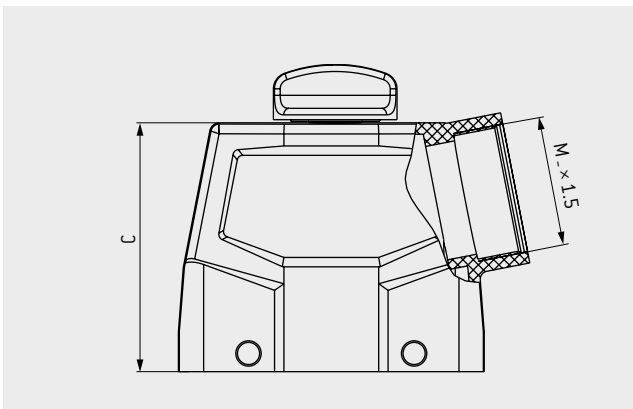

TECHNICAL DATA

Color of housing	Black (RAL 9005)
Material	Plastic PA6 GF, UL 94-V0
Protection class ¹	IP 50 IP 65 on request
Operating temperature	-40 °C to +125 °C
Cable clamp	see page 83
Number of locking cycles	see from page 56

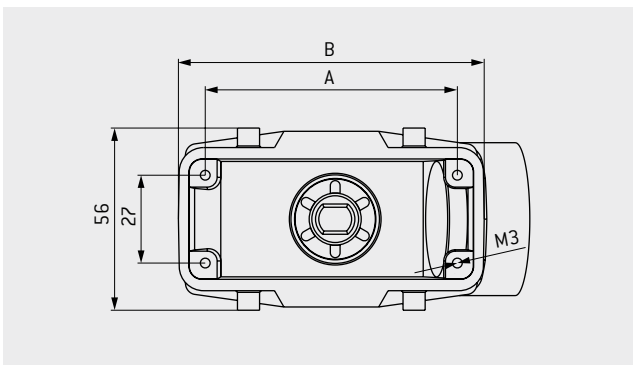

Size	Part number	Dim. A	Dim. B	Dim. C	Dim. M	Part number protective cover
		mm	mm	mm	cable entry	(see page 69)
2	613.091.514.908.308	57	74	72.5	M32	491.097.613.908.001
3	613.092.514.908.308	77.5	94	76.5	M40	492.097.613.908.001
4	613.093.514.908.308	104	121	76.5	M40	493.097.613.908.001

FOR A REDUCTION FROM M40 TO M32, SEE PAGE 83.

¹ IEC 60529:2013 (VDE 0470-1:2014) [Depends on the cable clamp(s) and spindle type used].

PLASTIC BULKHEAD MOUNTED HOUSING



For assembly of your device with spindle locking.

SPINDLE LOCKING

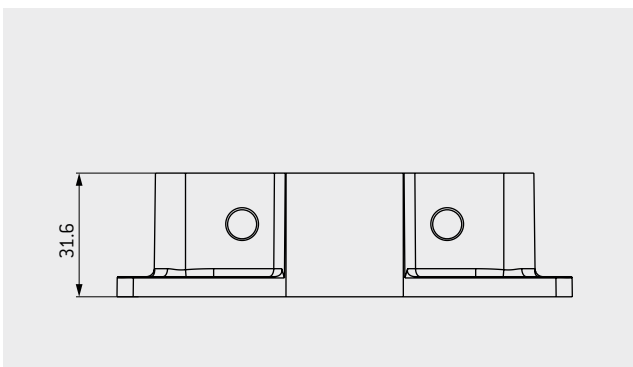

TECHNICAL DATA

Color of housing	Black (RAL 9005)
Material	Plastic PA6 GF, UL 94-V0
Protection class ¹	IP 50
	IP 65 on request
Operating temperature	-40 °C to +125 °C
Sealing	NBR; sealing material

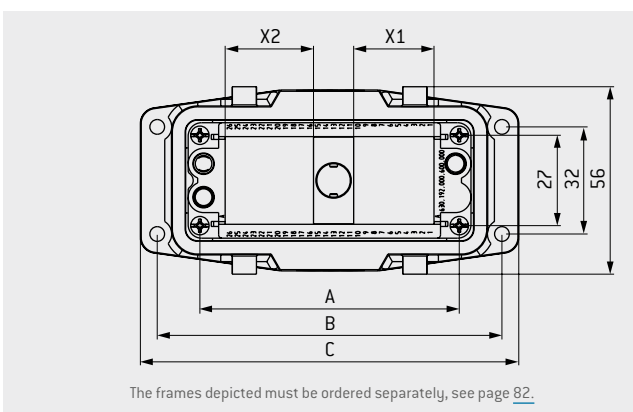

The frames depicted must be ordered separately, see page 82.

PANEL CUT-OUT

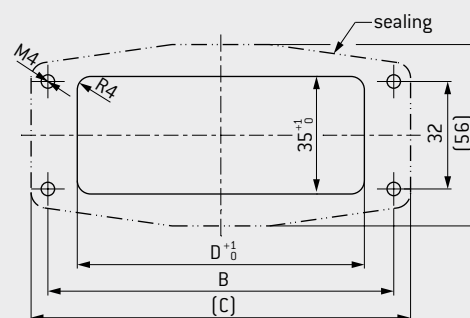

Size	Part number	Dim. A mm	Dim. B mm	Dim. C mm	Dim. D panel cut-out mm	X1 Units 2.54 mm	X2 Units 2.54 mm	Part number protective cover [see page 68]
2	612.091.010.908.000	57	83	93	67	5	6	491.097.612.908.001
3	612.092.010.908.000	77.5	103	114	87	9	10	492.097.612.908.001
4	612.093.010.908.000	104	130	140	114	14	15	493.097.612.908.001

¹ IEC 60529:2013 (VDE 0470-1:2014) [Depends on the spindle type used].

PLASTIC SURFACE MOUNTED HOUSING



For surface mounting on your device/wall with two side cable entries.

SPINDLE LOCKING

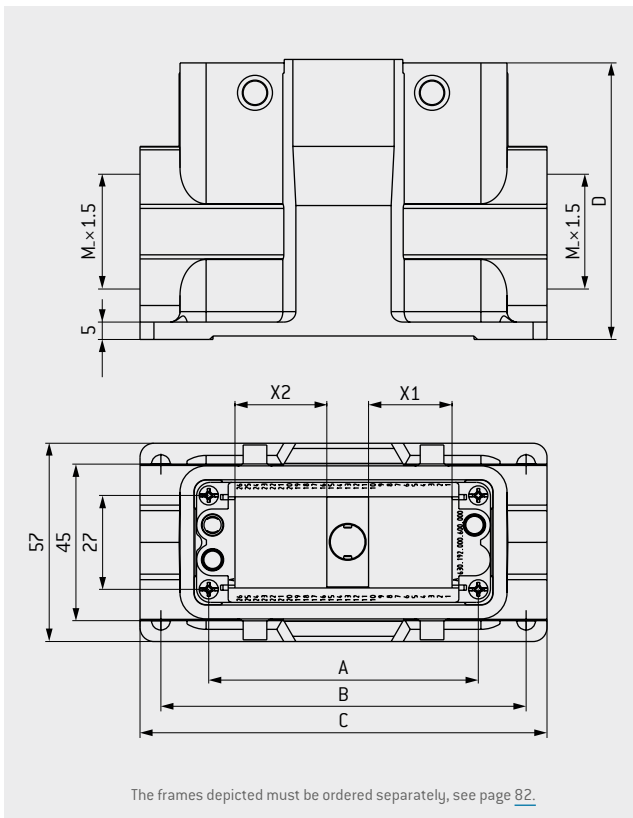

TECHNICAL DATA

Color of housing	Black (RAL 9005)
Material	Plastic PA6 GF, UL 94-V0
Protection class ¹	IP 50 IP 65 on request
Operating temperature	-40 °C to +125 °C
Sealing	NBR; sealing material
Cable clamp	see page 83

Size	Part number	Dim. A mm	Dim. B mm	Dim. C mm	Dim. D mm	X1 Units 2.54 mm	X2 Units 2.54 mm	Dim. M Cable entry	Part number protective cover [see page 68]
2	612.091.020.908.000	57	82	94	81.5	5	6	M32	491.097.612.908.001
3	612.092.020.908.000	77.5	105	117	81.5	9	10	M40	492.097.612.908.001
4	612.093.020.908.000	104	132	144	81.5	14	15	M40	493.097.612.908.001

FOR A REDUCTION FROM M40 TO M32, SEE PAGE 83.

¹ IEC 60529:2013 (VDE 0470-1:2014) [Depends on the cable clamp(s) and spindle type used].

PLASTIC CABLE HOOD



Plastic cable hood for assembly on cable and side cable entry.

TRANSVERSE LOCKING

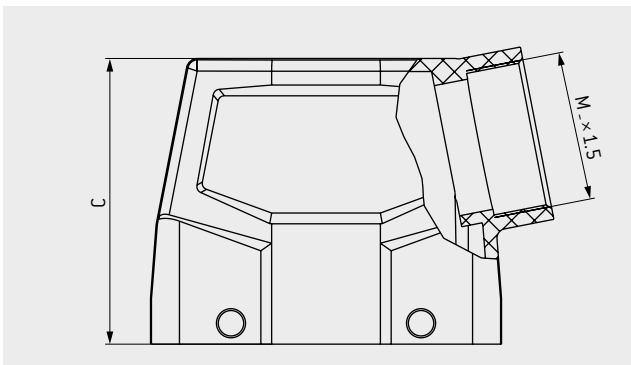

TECHNICAL DATA

Color of housing	Black (RAL 9005)
Material	Plastic PA6 GF, UL 94-V0
Protection class ¹	IP 65
Operating temperature	-40 °C to +125 °C
Cable clamp	see page 83
Number of locking cycles	5,000

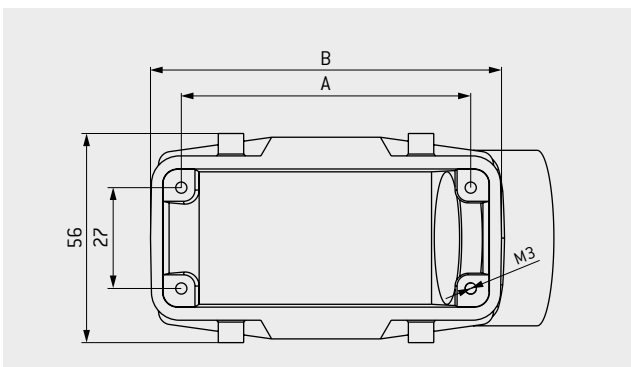

Size	Part number	Dim. A	Dim. B	Dim. C	Dim. M	Part number protective cover
		mm	mm	mm	Cable entry	[see page 69]
1	490.420.650.908.000	44	54	72.5	M32	490.097.613.908.001
2	491.420.650.908.000	57	74	72.5	M32	491.097.613.908.001
3	492.420.650.908.000	77.5	94	76.5	M40	492.097.613.908.001
4	493.420.650.908.000	104	121	76.5	M40	493.097.613.908.001

FOR A REDUCTION FROM M40 TO M32 AND FROM M32 TO M25, SEE PAGE [83](#).

¹ IEC 60529:2013 (VDE 0470-1:2014) [Depends on the cable clamp(s) used].

PLASTIC BULKHEAD MOUNTED HOUSING



For assembly of your device with transverse locking.

TRANSVERSE LOCKING

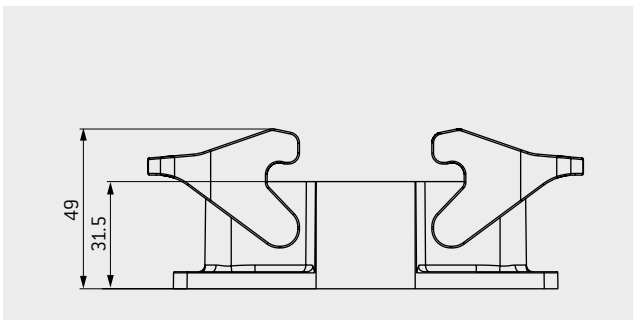

TECHNICAL DATA

Color of housing	Black (RAL 9005)
Material	Plastic PA6 GF, UL 94-V0
Protection class ¹	IP 65
Operating temperature	-40 °C to +125 °C
Sealing	NBR; sealing material

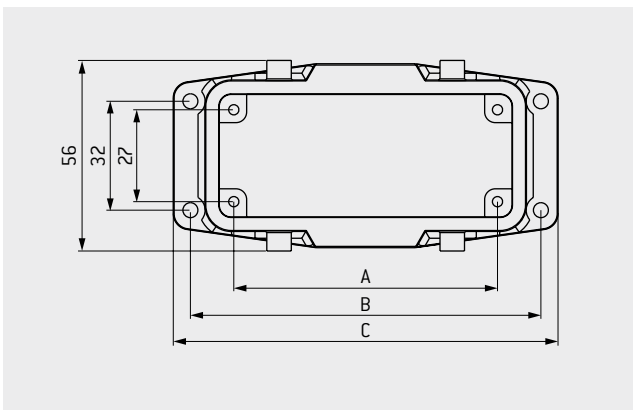

PANEL CUT-OUT

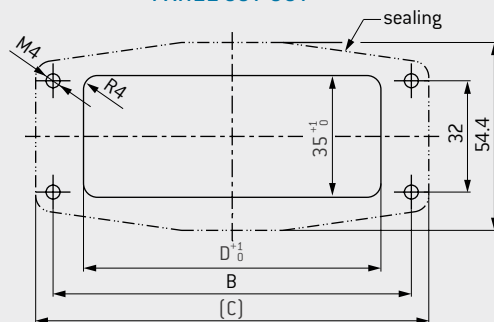

Size	Part number	Dim. A mm	Dim. B mm	Dim. C mm	Dim. D panel cut-out mm	Part number protective cover [see page 68]
1	490.120.600.908.000	44	70	80	53	490.097.612.908.000
2	491.120.600.908.000	57	83	93.2	66	491.097.612.908.000
3	492.120.600.908.000	77.5	103	113	86	492.097.612.908.000
4	493.120.600.908.000	104	130	140	113	493.097.612.908.000

¹ IEC 60529:2013 (VDE 0470-1:2014) [Depends on the cable hood used]

PLASTIC SURFACE MOUNTED HOUSING



For surface mounting on your device/wall with two side cable entries.

TRANSVERSE LOCKING

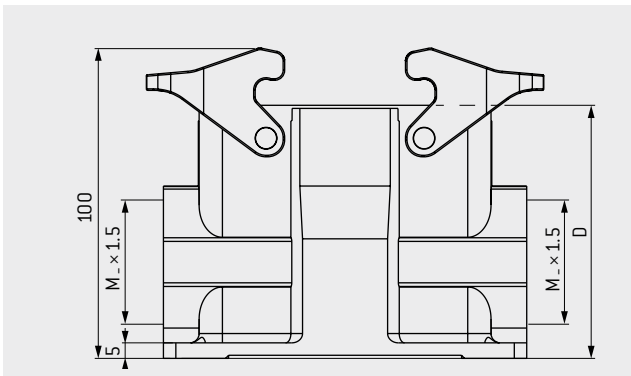

TECHNICAL DATA

Color of housing	Black (RAL 9005)
Material	Plastic PA6 GF, UL 94-V0
Protection class ¹	IP 65
Operating temperature	-40 °C to +125 °C
Sealing	NBR; sealing material
Cable clamp	see page 83

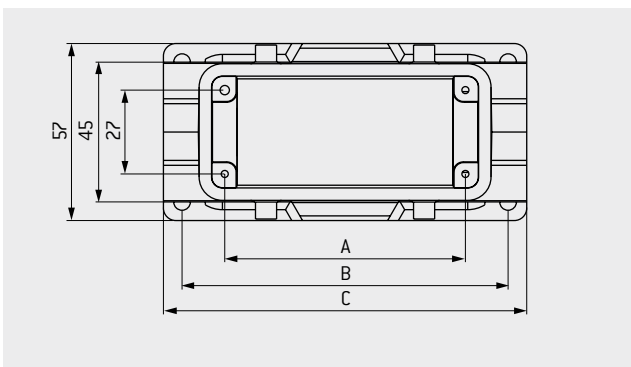

Size	Part number	Dim. A	Dim. B	Dim. C	Dim. D	Dim. M	Part number protective cover (see page 68)
		mm	mm	mm	mm	Cable entry	
1	490.120.650.908.000	44	70	82	74.7	M32	490.097.612.908.000
2	491.120.650.908.000	57	82	94	81.5	M32	491.097.612.908.000
3	492.120.650.908.000	77.5	105	117	81.5	M40	492.097.612.908.000
4	493.120.650.908.000	104	132	144	81.5	M40	493.097.612.908.000

FOR A REDUCTION FROM M40 TO M32 AND FROM M32 TO M25, SEE PAGE [83](#).

¹ IEC 60529:2013 (VDE 0470-1:2014) [Depends on the cable clamp and cable hood used].

PLASTIC PROTECTIVE COVER



For bulkhead and surface mounted housing with lanyard.

SPINDLE LOCKING

A



TRANSVERSE LOCKING

B



SPINDLE AND TRANSVERSE LOCKING

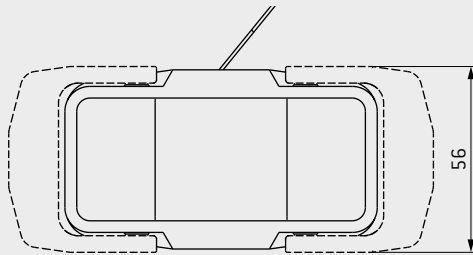

TECHNICAL DATA

Color of housing	Black (RAL 9005)
Material	Plastic PA6 GF, UL 94-V0
Protection class ¹	IP 65
Operating temperature	-40 °C to +125 °C

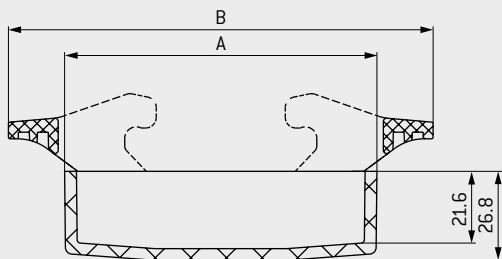

Dotted line and dim. B only applies for the spindle locking types.

Size	Part number A	Part number B	Dim. A	Dim. B
	Protective cover for transverse locking	Protective cover for transverse locking	mm	mm
1	–	490.097.612.908.000	61	95
2	491.097.612.908.001	491.097.612.908.000	74	108
3	492.097.612.908.001	492.097.612.908.000	94	128
4	493.097.612.908.001	493.097.612.908.000	121	155

¹ IEC 60529:2013 (VDE 0470-1:2014)

PLASTIC PROTECTIVE COVER

For cable hood with langard.



SPINDLE AND TRANSVERSE LOCKING



SPINDLE AND TRANSVERSE LOCKING

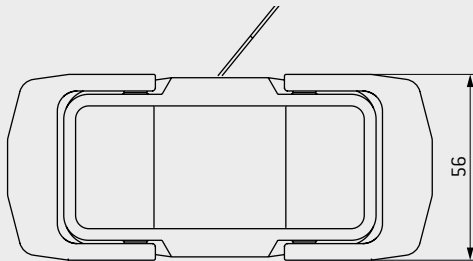

TECHNICAL DATA

Color of housing	Black (RAL 9005)
Material	Plastic PA6 GF, UL 94-V0
Protection class ¹	IP 65
Operating temperature	-40 °C to +125 °C
Sealing	NBR; sealing material
Locking	via the transverse lever locking included in the delivery

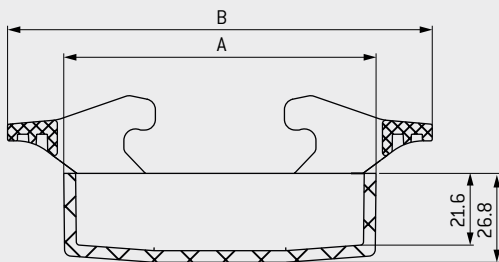

Size	Part number Protective cover for transverse locking	Part number Protective cover for transverse locking	Dim. A mm	Dim. B mm
1	–	490.097.613.908.001	61	95
2	491.097.613.908.001	491.097.613.908.001	74	108
3	492.097.613.908.001	492.097.613.908.001	94	128
4	493.097.613.908.001	493.097.613.908.001	121	155

¹ IEC 60529:2013 (VDE 0470-1:2014)

METAL CABLE HOOD



Connector housing for assembly on the cable. With straight and side cable entry.

LEVER LOCKING

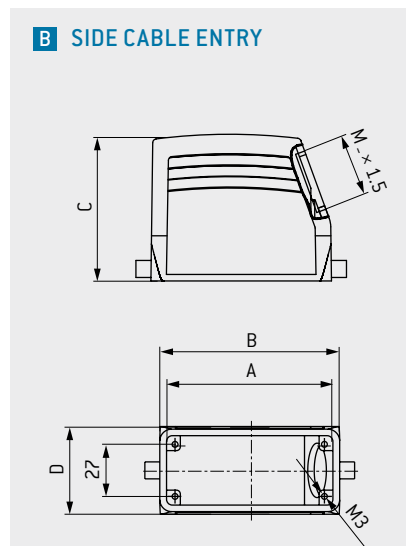
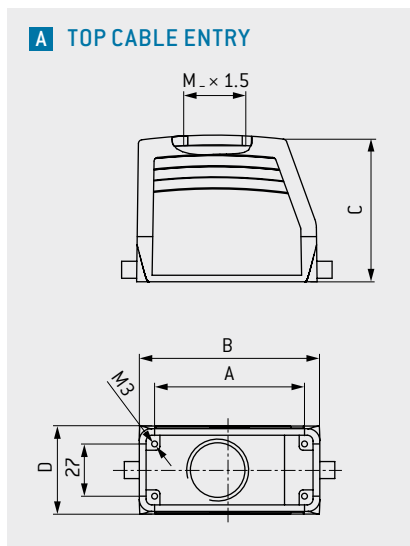

TECHNICAL DATA

Color of housing	Gray (standard similar to RAL 7001)
Material	Aluminium die casting
Protection class ¹	IP 65
Operating temperature	in mated condition -40 °C to +125 °C
Cable clamp	see page 83
Adapter	for PG clamp see page 84

With lever a locking minimum of 5,000 locking cycles are possible with lubrication. Up to 500 mating cycles there is no lubrication required.

Size	Part number A Top cable entry	Part number B Side cable entry	Dim. A mm	Dim. B mm	Dim. C mm	Dim. D mm	Dim. M Cable entry	Part number protective cover (see page 77)
1	490.214.450.644.102	490.414.450.644.102	44	60	52	43	M25	490.097.500.644.000
	490.215.450.644.102	490.415.450.644.102			72		M32	
2	491.214.450.644.102	491.414.450.644.102	57	73	52	43	M25	491.097.212.644.000
	491.215.450.644.102	491.415.450.644.102			72		M32	
3	492.215.450.644.102	492.415.450.644.102	77.5	93.5	76	45.5	M32	492.097.214.644.000
4	493.215.450.644.102	493.415.450.644.102	104	120	76	45.5	M32	493.097.214.644.000
	493.217.550.644.000	493.417.550.644.000					M40	

¹ IEC 60529:2013 (VDE 0470-1:2014) [Depends on the cable clamp(s) used].

METAL CABLE HOOD XXL

Connector housing for assembly on the cable. With expanded assembly space as well as side and top M50 cable entry.



LEVER LOCKING

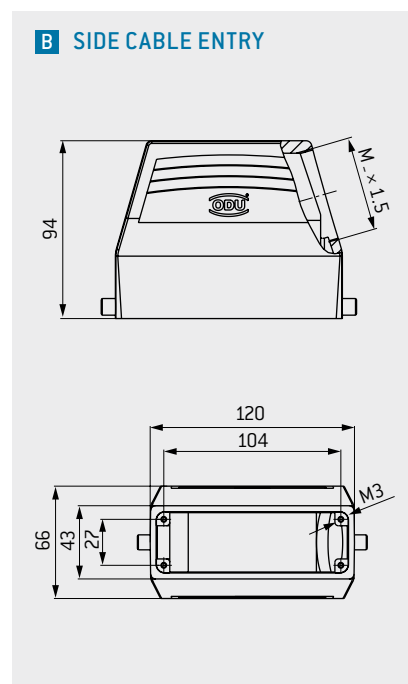
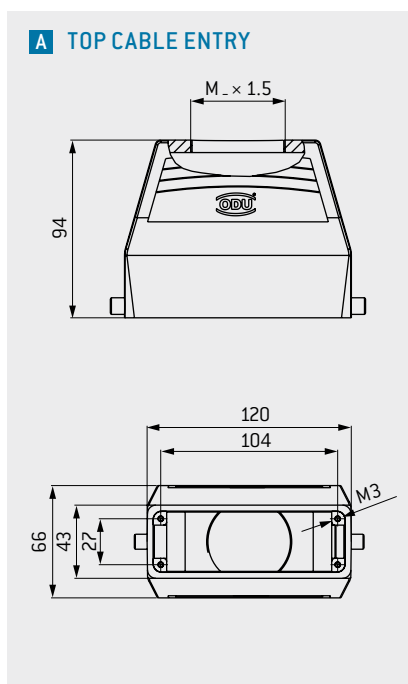

TECHNICAL DATA

Color of housing	Gray (standard similar to RAL 7001)
Material	Aluminium die casting
Protection class ¹	IP 65
Operating temperature	in mated condition -40 °C to +125 °C
Cable clamp	see page 83

With lever a locking minimum 5,000 locking cycles are possible with lubrication. Up to 500 mating cycles there is no lubrication required.

Size	Part number A Top cable entry	Part number B Side cable entry	Dim. M Cable entry	Part number protective cover (see page 77)
4	493.218.550.644.000	493.419.550.644.000	M50	493.097.214.644.000

¹ IEC 60529:2013 (VDE 0470-1:2014) [Depends on the cable clamp(s) used].

METAL BULKHEAD MOUNTED HOUSING



For mounting on the device.

LEVER LOCKING

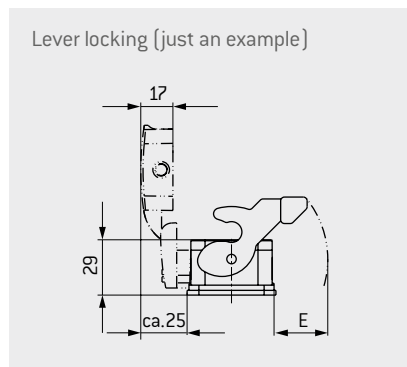
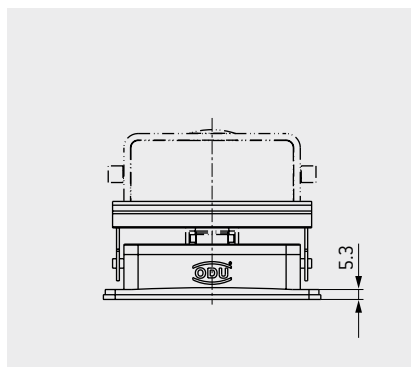

TECHNICAL DATA

Color of housing	Gray (standard similar to RAL 7001)
Material	Aluminium die casting
Protection class ¹	IP 65
Operating temperature	in mated condition -40 °C to +125 °C (short duration) -40 °C to +85 °C (operating)
Sealing	NBR; sealing material FKM on request (higher temperature range)

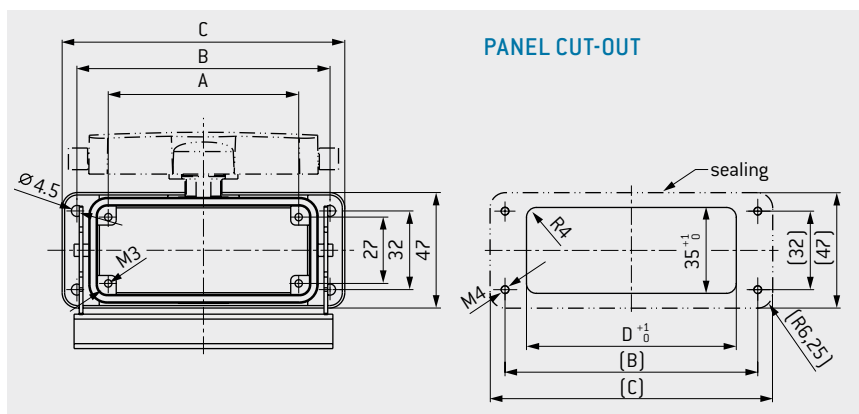

With lever a locking minimum 5,000 locking cycles are possible with lubrication. Up to 500 mating cycles there is no lubrication required.

Size	Part number A Without protective cover	Part number B With protective cover	Dim. A mm	Dim. B mm	Dim. C mm	Dim. D Panel cut-out mm	Dim. E mm
1	490.130.400.644.000	490.131.400.644.000	44	70	82	52.2	≈ 22
2	491.130.400.644.000	491.131.400.644.000	57	83	95	65.2	≈ 27
3	492.130.400.644.000	492.131.400.644.000	77.5	103	115	85.5	≈ 28
4	493.130.400.644.000	493.131.400.644.000	104	130	143	112.2	≈ 28

¹ IEC 60529:2013 (VDE 0470-1:2014) [Depends on the hood cable clamp(s) used].

METAL SURFACE MOUNTED HOUSING



For surface mounting on your device/wall with two side cable entries.

LEVER LOCKING

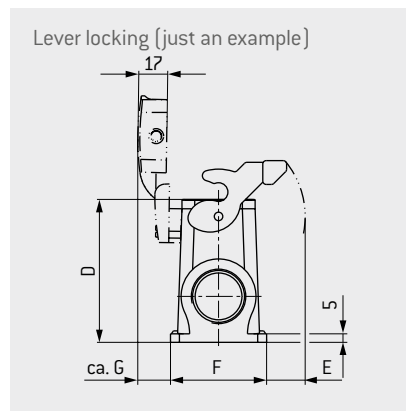
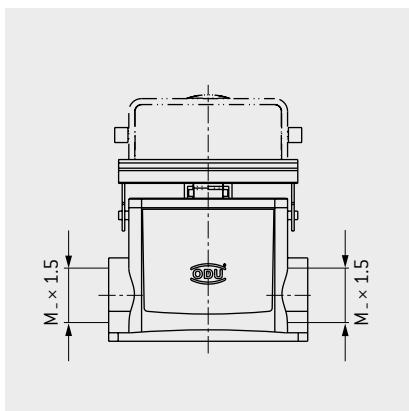

TECHNICAL DATA

Color of housing	Gray (standard similar to RAL 7001)
Material	Aluminium die casting
Protection class ¹	IP 65
Operating temperature	in mated condition -40 °C to +125 °C (short duration) -40 °C to +85 °C (operating)
Sealing	NBR; sealing material FKM on request (higher temperature range)
Adapter	for PG clamp see page 84

With lever a locking minimum 5,000 locking cycles are possible with lubrication. Up to 500 mating cycles there is no lubrication required.

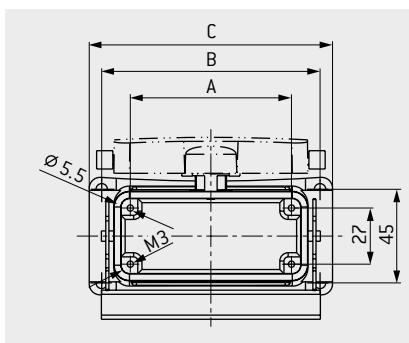

Size	Part number A Without protective cover	Part number B With protective cover	Dim. A mm	Dim. B mm	Dim. C mm	Dim. D mm	Dim. E mm	Dim. F mm	Dim. G mm	Dim. M Cable entry
1	490.133.450.644.102	490.135.450.644.102	44	70	82	74	≈ 17	55.5	20	M32
2	491.133.450.644.102	491.135.450.644.102	57	82	92.5	74	≈ 23	55.5	20	
3	492.133.450.644.102	492.135.450.644.102	77.5	105	117	84	≈ 23	56.5	20	
4	493.133.450.644.102	493.135.450.644.102	104	132	144	84	≈ 22	58	19	

M40 CABLE ENTRY AVAILABLE UPON REQUEST.

¹ IEC 60529:2013 [VDE 0470-1:2014] [Depends on the base and hood cable clamps used].

METAL CABLE HOOD WIDE



With straight and side cable entry for double contact arrangement on the frame.

LEVER LOCKING

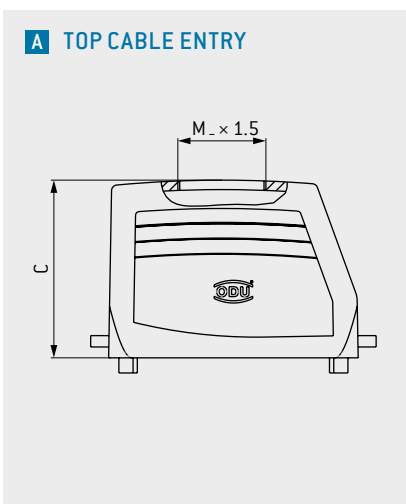

TECHNICAL DATA

Color of housing	Gray (standard, similar to RAL 7001)
Material	Aluminium die casting
Protection class ¹	IP 65
Operating temperature	in mated condition without housing sealing: -40 °C to +125 °C
Cable clamp	see page 83

Housing suitable for two standard frames size 3 or 4.

2 × size 3 = size 5

2 × size 4 = size 6

With lever a locking minimum 5,000 locking cycles are possible with lubrication. Up to 500 mating cycles there is no lubrication required.

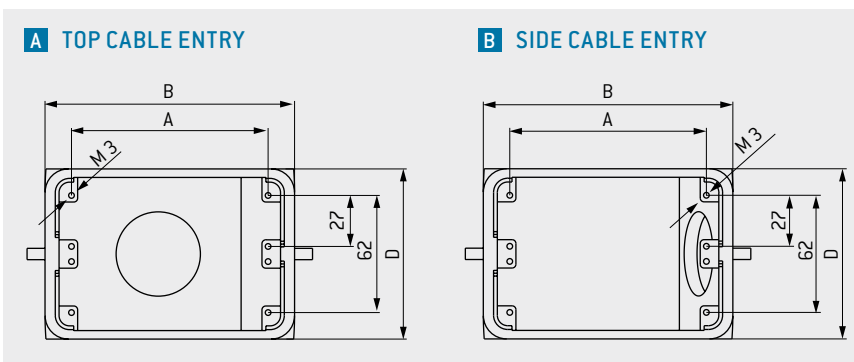

Size	Part number A Top cable entry	Part number B Side cable entry	Dim. A mm	Dim. B mm	Dim. C mm	Dim. D mm	Dim. M Cable entry
5	494.215.550.644.000	494.415.550.644.000	77.5	94	79	82.5	M40
6	495.215.550.644.000	495.415.550.644.000	104	132	94	90	M50

¹ IEC 60529:2013 (VDE 0470-1:2014) [Depends on the cable clamp(s) used].

METAL BULKHEAD MOUNTED HOUSING FOR CABLE HOOD WIDE

For mounting on the device.

LEVER LOCKING

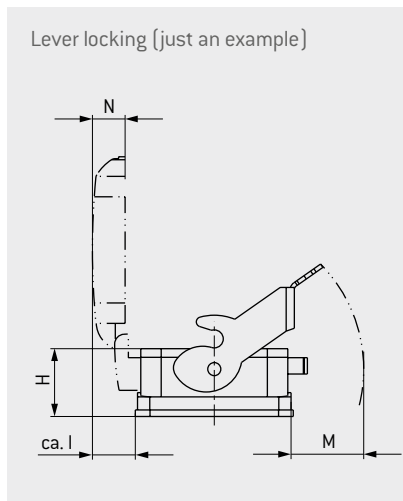
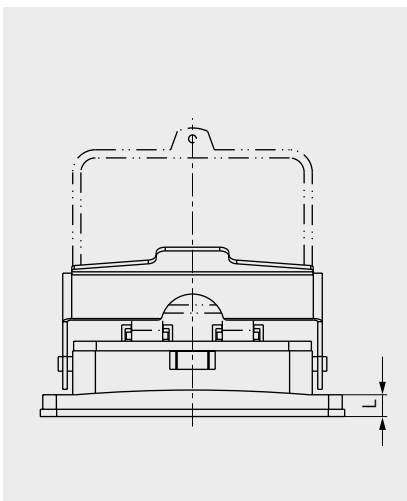

TECHNICAL DATA

Color of housing	Gray (standard similar to RAL 7001)
Material	Aluminium die casting
Protection class ¹	IP 65
Operating temperature	in mated condition -40 °C to +125 °C (short duration) -40 °C to +85 °C (operating)
Sealing	NBR; sealing material FKM on request (higher temperature range)

With lever a locking minimum 5,000 locking cycles are possible with lubrication. Up to 500 mating cycles there is no lubrication required.

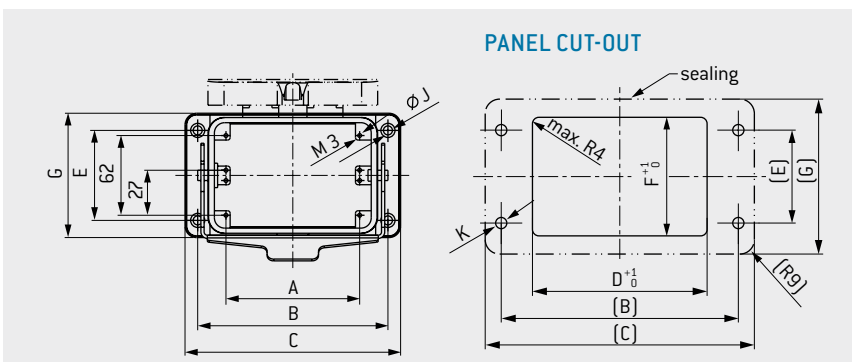

Size	Part number A Without protective cover	Part number B With protective cover	Dim. A mm	Dim. B mm	Dim. C mm	Dim. D mm	Dim. E mm	Dim. F mm	Dim. G mm	Dim. H mm	Dim. I mm	Dim. J mm	Dim. K mm	Dim. L mm	Dim. M mm	Dim. N mm
5	494.130.500.644.000	494.131.500.644.000	77.5	110	127	79	65	74	89	38	≈ 23	5.5	M5	7	31	17
6	495.130.500.644.000	495.131.500.644.000	104	148	168	117	70	80	96.7	41.5	≈ 26	7	M6	12	43	20

¹ IEC 60529:2013 [VDE 0470-1:2014] [Depends on the hood cable clamp(s) used].

METAL CABLE TO CABLE HOOD



With top cable entry. For a flying cable to cable connection.

LEVER LOCKING

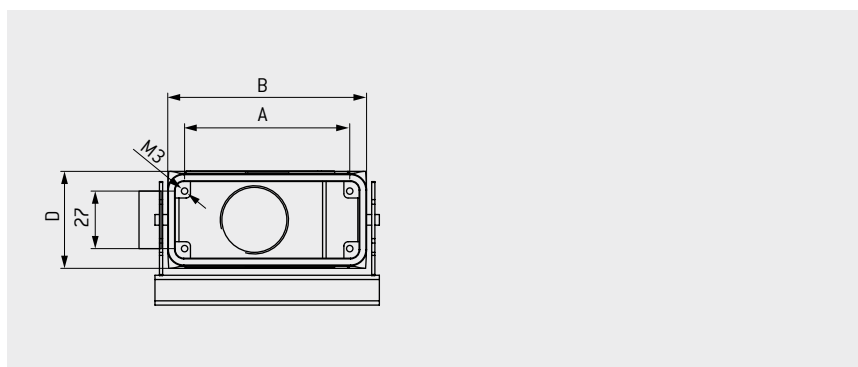
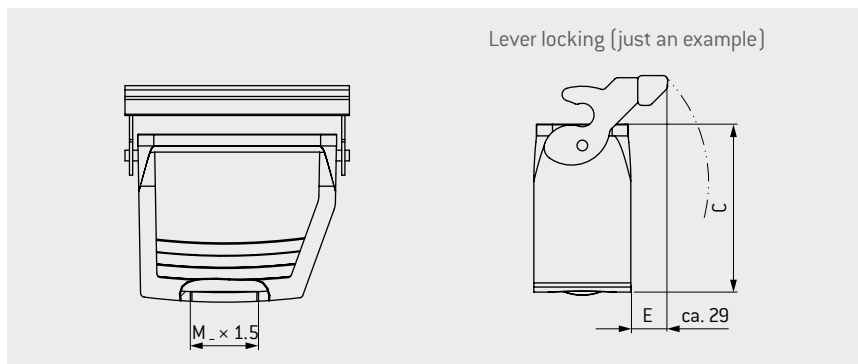

TECHNICAL DATA

To build a cable to cable connection. Suitable for use with cable hoods (page 70).

Color of housing	Gray (standard similar to RAL 7001)
Material	Aluminium die casting
Protection class ¹	IP 65
Operating temperature	in mated condition -40 °C to +125 °C (short duration) -40 °C to +85 °C (operating)
Sealing	NBR; sealing material FKM on request (higher temperature range)
Cable clamp	see page 83
Adapter	for PG clamp see page 84

With lever a locking minimum 5,000 locking cycles are possible with lubrication. Up to 500 mating cycles there is no lubrication required.

Size	Part number	Dim. A	Dim. B	Dim. C	Dim. D	Dim. M	Part number
		mm	mm	mm	mm	Cable entry	Protective cover (see page 82)
1	490.331.450.644.102	44	60	75	43	M32	490.097.500.644.001
2	491.331.450.644.102	57	73	75	43		491.097.133.644.000
3	492.331.450.644.102	77.5	93.3	79	45.5		492.097.133.644.000
4	493.331.450.644.102	104	120	79	45.5		493.097.133.644.000

M40 CABLE ENTRY AVAILABLE UPON REQUEST.

¹ IEC 60529:2013 (VDE 0470-1:2014) [Depends on the hood cable clamp(s) used].

METAL PROTECTIVE COVER



For metal housing.

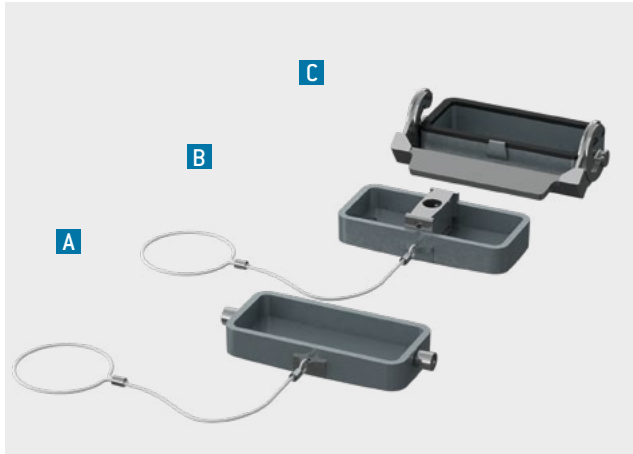

TECHNICAL DATA

Color Gray (standard, similar to RAL 7001)

Protection class IP 65 in locked condition

Metal protective cover with locking latch [C]
Metal protective cover with bolt and lanyard [A]

Protection class IP 54 in locked condition

Metal protective cover with middle section for spindle locking with lanyard [B]

Material Aluminium die casting (body)
Temperature range $-40\text{ }^{\circ}\text{C}$ to $+125\text{ }^{\circ}\text{C}$
Sealing NBR; sealing material

A METAL PROTECTIVE COVER

for bulkhead mounted, surface mounted housing and cable-to-cable-hoods

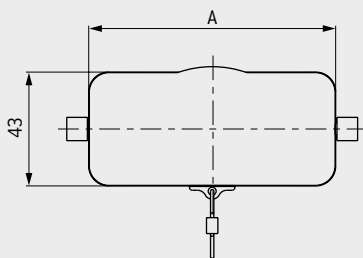

A VIEW WITHOUT LANYARD

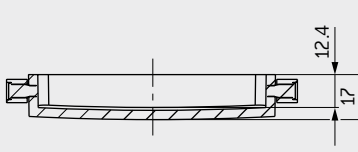

B METAL PROTECTIVE COVER

for cable hood and cable hood XXL for spindle locking

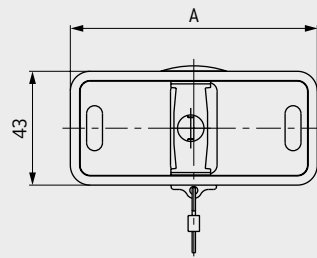

B VIEW WITHOUT LANYARD

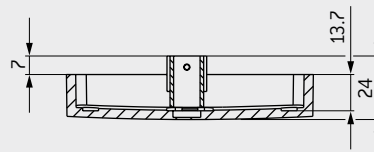

C METAL PROTECTIVE COVER

for cable hood and cable hood XXL for lever locking

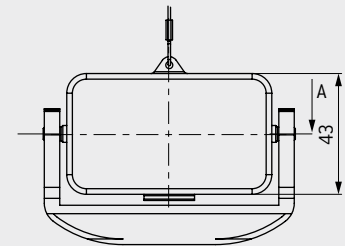

Lever locking just an example.

C VIEW WITHOUT LOCKING LATCH

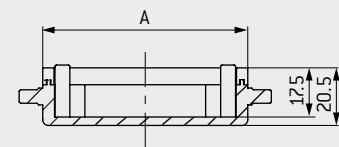

Size	IP 65 Part number A Metal protective cover with bolt and lanyard	IP 50 Part number B Metal protective cover for spindle locking with lanyard and middle section	IP 65 Part number C Metal protective cover with locking latch	Dim. A mm
1	490.097.500.644.001	—	490.097.500.644.000	60
2	491.097.133.644.000	491.097.613.644.000	491.097.212.644.000	73
3	492.097.133.644.000	492.097.613.644.000	492.097.214.644.000	93.5
4/XXL	493.097.133.644.000	493.097.613.644.000	493.097.214.644.000	120

CABLE HOOD IN IP 68/IP 69

For applications with extreme requirements. With 360° EMC shielding according to VG 95373-41:1997.
On request.

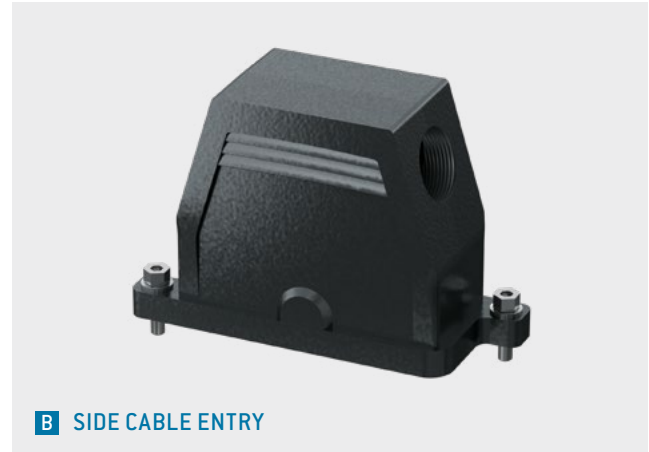
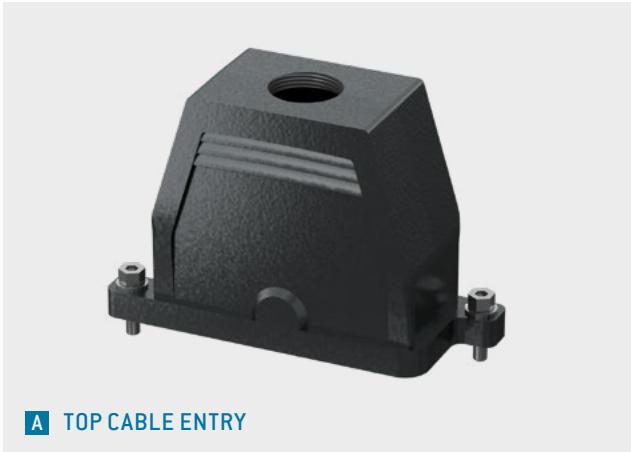

INSERTION LOSS

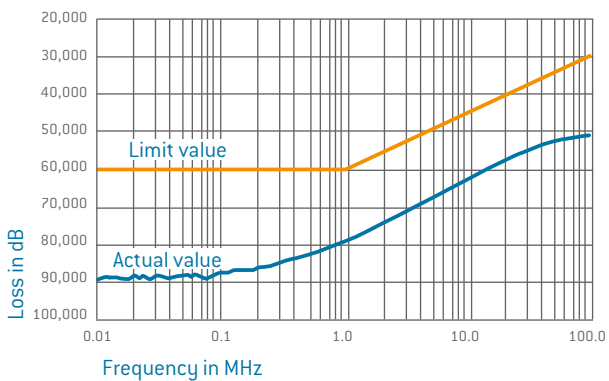

TECHNICAL DATA

EMC model

Surface	Electrically conductible
Sealing	Inside
Housing	Aluminium die casting alloy seawater resistance
Temperature range	-50 °C to +120 °C
Shielding attenuation	ca. 65 dB

Corrosion protection model

Pressure tightness	> 5 bar
Color	Black (similar to RAL 9002)
Protection class ¹	IP 68, IEC 60529:2013 (VDE 0470-1:2014) IP 69, IEC 60529:2013 (VDE 0470-1:2014)

Screw locking

Application areas

Used in EMC shielded applications.
Housing construction according to IEC 61373:2010 (VDE 0115-106:2011)
Cat. 2 (bogie) from rail engineering.

Size	Part number A Top cable entry	Part number B Side cable entry	Dim. B mm	Dim. C mm	Dim. M mm	Dim. H mm
1	490.260.550.641.000	490.261.550.641.000	132	44	M32	100.5
2	491.262.550.641.000	491.263.550.641.000	144	57	M32	100.5
3	492.262.550.641.000	492.263.550.641.000	164	77.5	M32	110.5
4	493.262.550.641.000	493.263.550.641.000	191	104	M40	110.5

¹ IEC 60529:2013 (VDE 0470-1:2014) [Depends on the hood cable clamp(s) used].



A TOP CABLE ENTRY

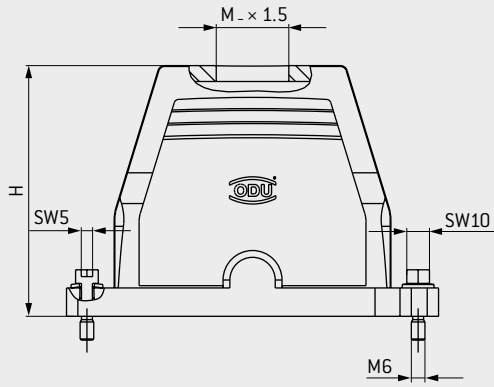

B SIDE CABLE ENTRY

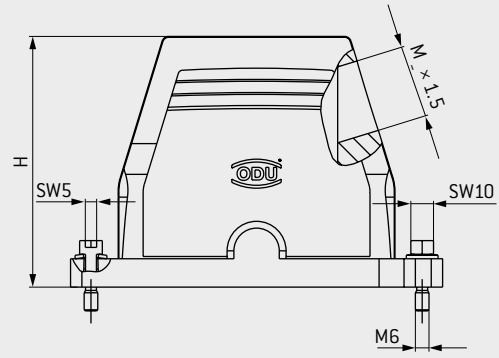

A

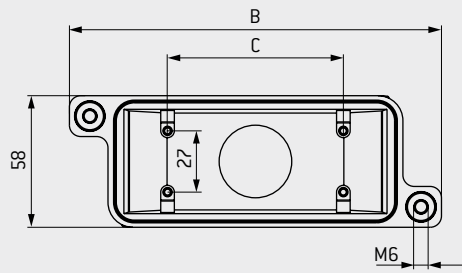

B

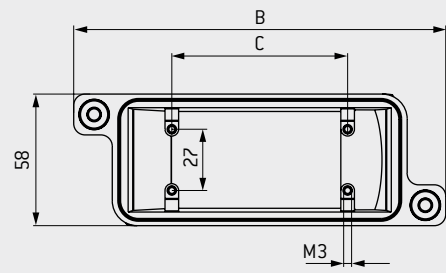

BULKHEAD MOUNTED- AND SURFACE MOUNTED HOUSING IN IP 68/IP 69

For applications with extreme requirements. With 360° EMC shielding according to VG 95373-41:1997.

On request.



A BULKHEAD MOUNTED HOUSING



B SURFACE MOUNTED HOUSING

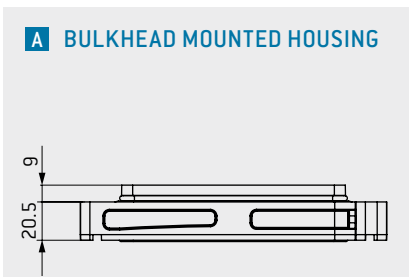

A BULKHEAD MOUNTED HOUSING

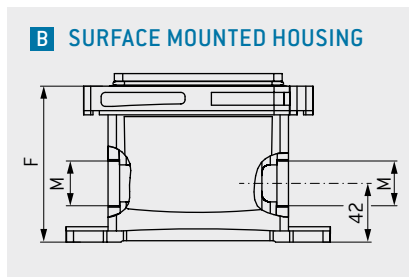

B SURFACE MOUNTED HOUSING

TECHNICAL DATA

EMC model

Surface	Electrically conductible
Sealing	Inside protected
Housing	Aluminium die casting alloy seawater resistance
Temperature range	-50 °C to +120 °C
Shielding attenuation	ca. 65 dB

Corrosion protection model

Pressure tightness	> 5 bar
Color	Black (similar to RAL 9002)
Protection class ¹	IP 68, IEC 60529:2013 (VDE 0470-1:2014) IP 69, IEC 60529:2013 (VDE 0470-1:2014)
Sealing	Conductive silicone

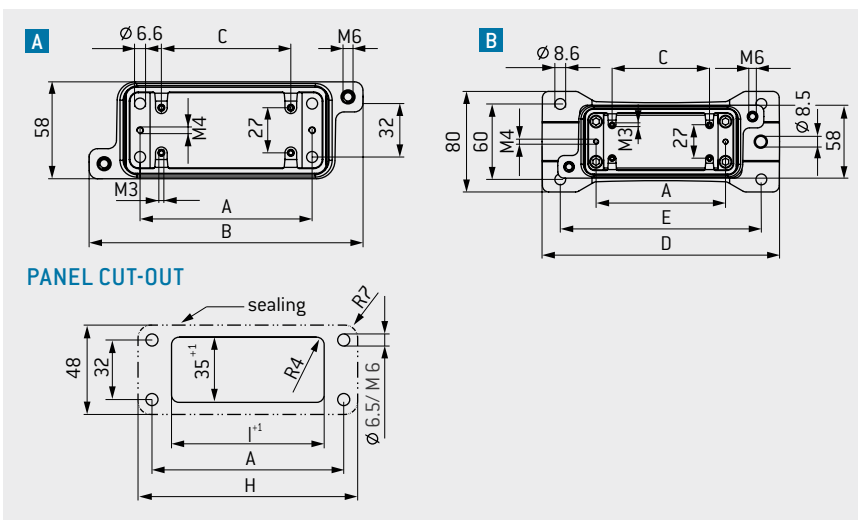

PANEL CUT-OUT

Application areas

Used in EMC shielded applications. Housing construction according to IEC 61373:2010 (VDE 0115-106:2011, bogie) from rail engineering.

Size	Part number Bulkhead mounted housing	Part number Surface mounted housing	Dim. A mm	Dim. B mm	Dim. C mm	Dim. D mm	Dim. E mm	Dim. F mm	Dim. H mm	Dim. I mm	Dim. M Cable entry
1	490.160.500.641.000	490.161.550.641.000	70	132	44	156	127	100.5	85	48	M32
2	491.161.500.641.000	491.162.550.641.000	83	144	57	169	140	100.5	98	60	M32
3	492.161.500.641.000	492.162.550.641.000	103	164	77.5	189	160	111.5	118	82	M32
4	493.161.500.641.000	493.162.550.641.000	130	191	104	216	187	111.5	145	108	M40

¹ IEC 60529:2013 (VDE 0470-1:2014) [Depends on the base and hood cable clamps used].

PROTECTIVE COVER FOR BULKHEAD MOUNTED AND SURFACE MOUNTED HOUSING IN IP 68/IP 69



For applications with extreme requirements. With 360° EMC shielding according to VG 95373-41:1997.
On request.

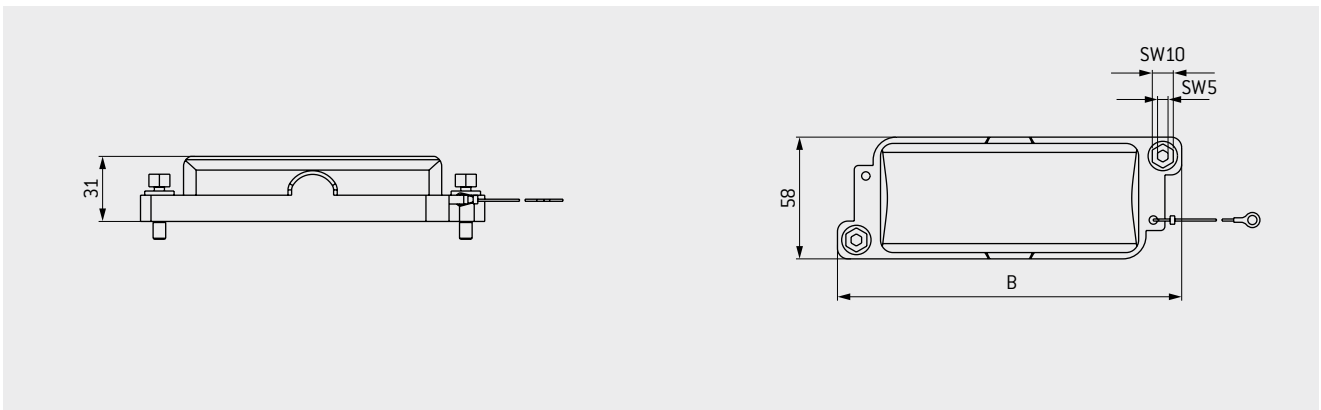

Size	Part number protective cover for bulkhead mounted and surface mounted housing with lanyard	Dim. B mm
1	490.060.500.641.000	132
2	491.060.500.641.000	144
3	492.060.500.641.000	164
4	493.060.500.641.000	191

ODU-MAC® FRAME FOR HOUSING



With grounded housing. (The frame is not required for the ODU-MAC® ZERO.)

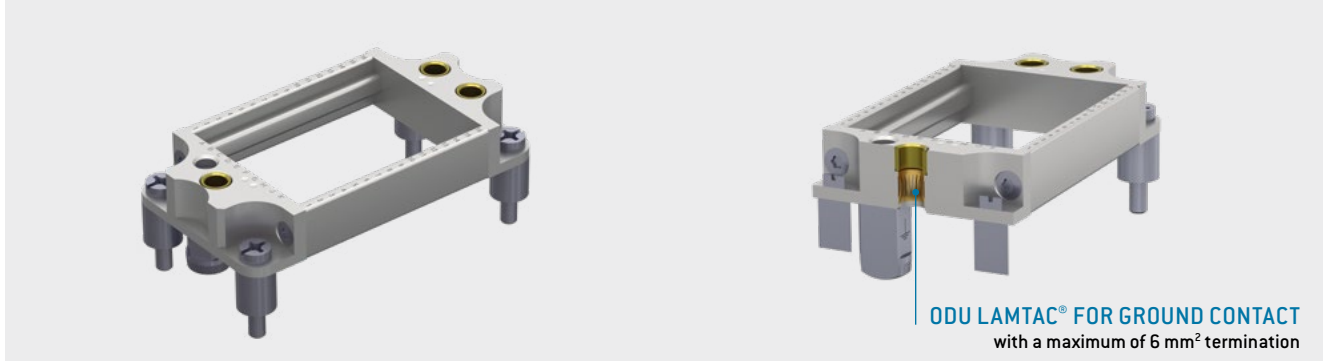

SOCKET FRAME WITH GUIDING BUSHES

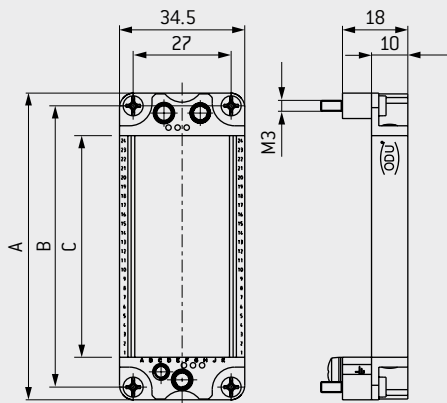

Sockets in bulkhead mounted housing, cable to cable hood or surface mounted housing. Pins in cable hood. Modules are mounted, contacts are not fixed enclosed. Coding possibilities see page 86.

PIN FRAME WITH GUIDING PIN

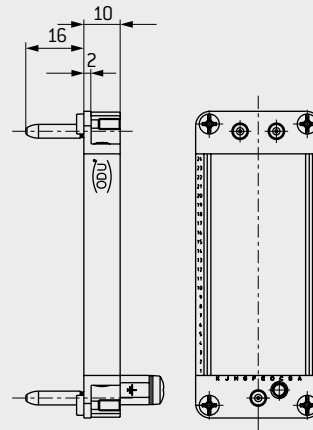

For the height of the contact pins the same dimensions are valid as described by the respective modules.

Size	Part number Socket frame	Part number Pin frame	Max. units 2.54 mm ¹	Dim. A mm	Dim. B mm	Dim. C mm
ZERO	No frame required.	No frame required.	9	–	–	–
1	610.190.000.600.000	611.190.000.600.000	10	51	44	25.5
2	610.191.000.600.000	611.191.000.600.000	16	64	57	40.8
3	610.192.000.600.000	611.192.000.600.000	24	84.5	77.5	61.1
4/XXL	610.193.000.600.000	611.193.000.600.000	34	111	104	86.5

FRAMES FOR CABLE HOOD WIDE

5	2 × part number size 3	2 × part number size 3	2 × 24	84.5	77.5	61.1
6	2 × part number size 4	2 × part number size 4	2 × 34	111	104	86.5

Please note that when equipping size 5 and 6 housings two frames are required.

¹ If the configuration doesn't fill the frame completely, please use blank modules (see page 164).

CABLE CLAMP AND REDUCING RING



CABLE CLAMP¹ FOR HOUSINGS ACCORDING TO IEC 62444:2010 (VDE 0619:2014)



TECHNICAL DATA

Material Body	PA
Sealing	NBR; sealing material
Protection class	IP 68 to 5 bar
Temperature range	-40 °C to +100 °C

EMC clamp on request.

Part number	Thread	Color	Width across flats	Tightening torque Nm	Cable diameter mm		
					min.	max.	
027.825.060.130.007	M25 × 1.5	Gray	30	8	6	13	
027.825.090.170.007					9	17	
027.832.070.150.007	M32 × 1.5		36	10	7	15	
027.832.110.210.007					11	21	
027.840.190.280.007	M40 × 1.5		46	13	19	28	
027.850.270.350.007	M50 × 1.5		55	15	27	35	
027.825.060.130.003	M25 × 1.5		White (RAL 7035)	30	8	6	13
027.825.090.170.003						9	17
027.832.070.150.003	M32 × 1.5			36	10	7	15
027.832.110.210.003						11	21
027.840.190.280.003	M40 × 1.5	46		13	19	28	
027.832.070.150.008	M32 × 1.5	Black		36	10	7	15
027.832.110.210.008						11	21
027.840.190.280.008	M40 × 1.5			46	13	19	28

REDUCING RING FOR PLASTIC HOUSING



TECHNICAL DATA

Color	Black (RAL 9005)
Material	Plastic PA6 GF20, UL 94-V0
Protection class	IP65
Temperature range	-40 °C to +125 °C
Sealing	NBR; sealing material

Part number	External thread	Internal thread
921.000.006.000.360	M32 × 1.5	M25 × 1.5
921.000.006.000.356	M40 × 1.5	M32 × 1.5

¹ Delivery doesn't contain cable clamp, but o-ring is enclosed with the housing.

ADAPTER RING, BLIND GROMMET AND LOCKNUT



ADAPTER RING FOR CABLE CLAMPS WITH PG THREAD

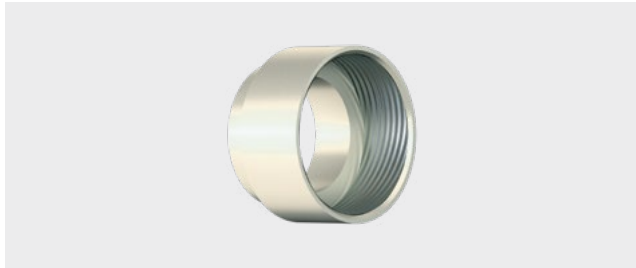

TECHNICAL DATA

Material Nickel-plated brass

Part number	External thread	Internal thread
921.000.006.000.254	M25 × 1.5	PG 21
921.000.006.000.255	M32 × 1.5	PG 29
921.000.006.000.267	M32 × 1.5	M40 × 1.5

BLIND GROMMET FOR SURFACE MOUNTED HOUSING



TECHNICAL DATA

Color Gray
 Material PA fiber glass reinforced
 Protection class IP68
 Temperature range -40 °C to +125 °C
 Sealing NBR; sealing material

Part number	Thread
921.000.006.000.279	M25 × 1.5
921.000.006.000.268	M32 × 1.5
On request	M40 × 1.5
On request	M50 × 1.5

LOCKNUT FOR CABLE CLAMP



TECHNICAL DATA

Material Nickel-plated brass

Part number	Thread
931.000.003.000.112	M32 × 1.5
931.000.003.000.113	M40 × 1.5

For fixing the cable clamp in the ODU-MAC strain relief housing .

PROTECTIVE TRANSPORT COVER



For protection of the assembled connector during transport.



TECHNICAL DATA

Material Plastic
Color Black [similar to RAL 9002]

Size	Part number	
	With carry lanyard	Without carry lanyard
1	490.097.900.924.000	490.097.900.924.101
2	491.097.900.924.000	491.097.900.924.101
3	492.097.900.924.000	492.097.900.924.101
4/XXL	493.097.900.924.000	493.097.900.924.101

SILICONE BEND RELIEFS FOR ODU-MAC® ZERO



TECHNICAL DATA

Material Silicone
Temperature -50 °C to $+200\text{ °C}$

DESCRIPTION

Bend reliefs for cable- \varnothing 8–14.5 mm
(MINI-SNAP Size 4, Silicone)
Ideal for color coding.

Part number	Dim. L mm	Cable jacket (\varnothing outside)	
		min.	max.
704.023.____.965.080	60	8	10
704.023.____.965.100		10	12
704.023.____.965.120		12	14
704.023.____.965.140		14	16

Color code	Color	RAL no. ¹ (similar)
202	Red	3020
203	White ²	9010
204	Yellow	1016
205	Green	6029
206	Blue	5002
207	Gray ²	7005
208	Black ²	9005

¹ Due to variations in raw materials, colors may differ slightly from RAL numbers. ² Standard colors with short delivery period.

CODING OPTIONS FOR LEVER LOCKING



To prevent mismatching.

In order to prevent mismatching, it is in some cases useful to provide the connection systems with a coding system.

Instead of cylinder screws, coding pins and coding sockets can be used in the ODU-MAC in the housing. ODU offers 16 different coding options. Standard frames do not include additional coding upon delivery. If several adjacent connectors are used, this can prevent mismatching.



CODING OPTIONS

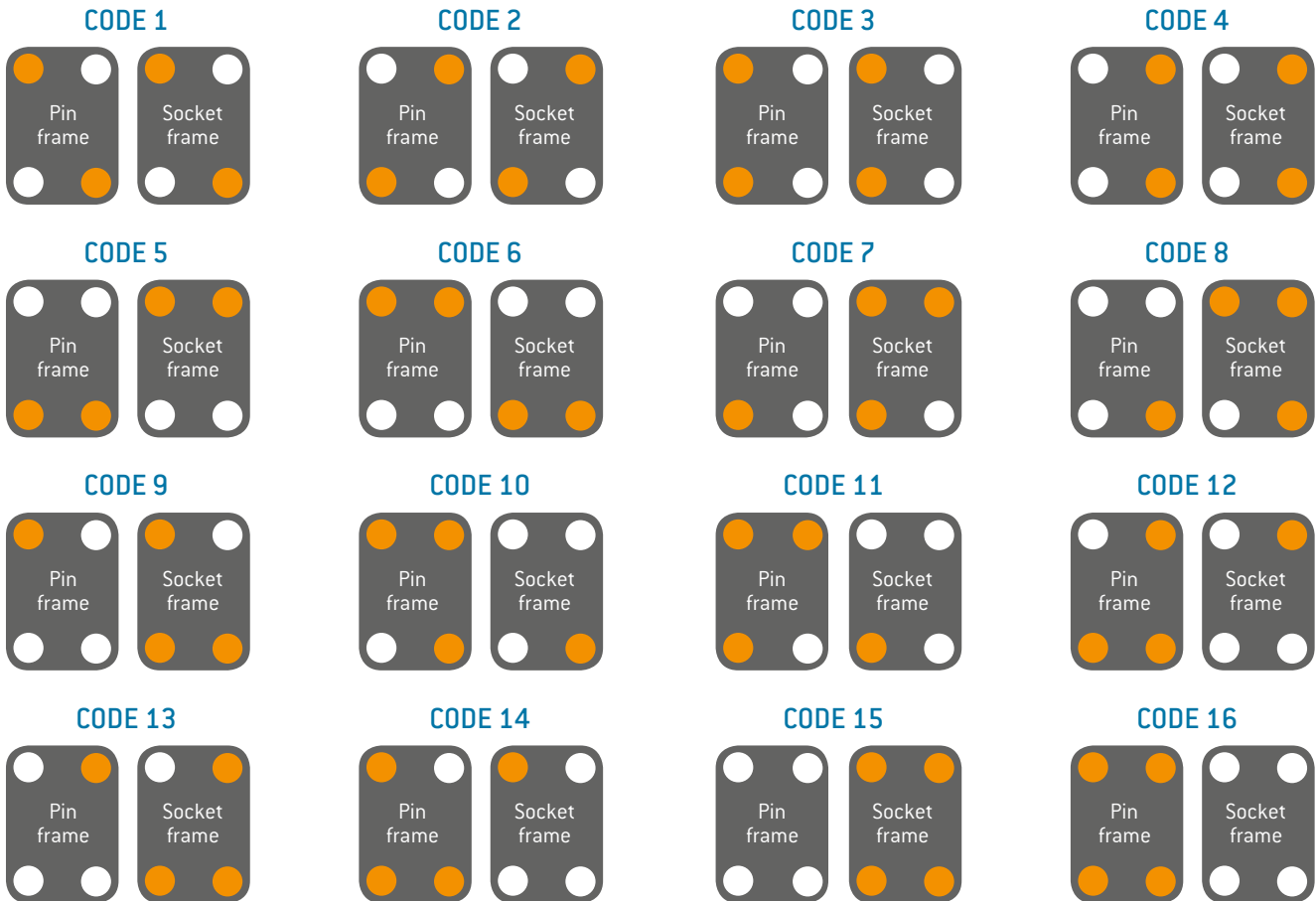

- = Coding pin
- = Coding socket



CODING EXAMPLE

CODE 1

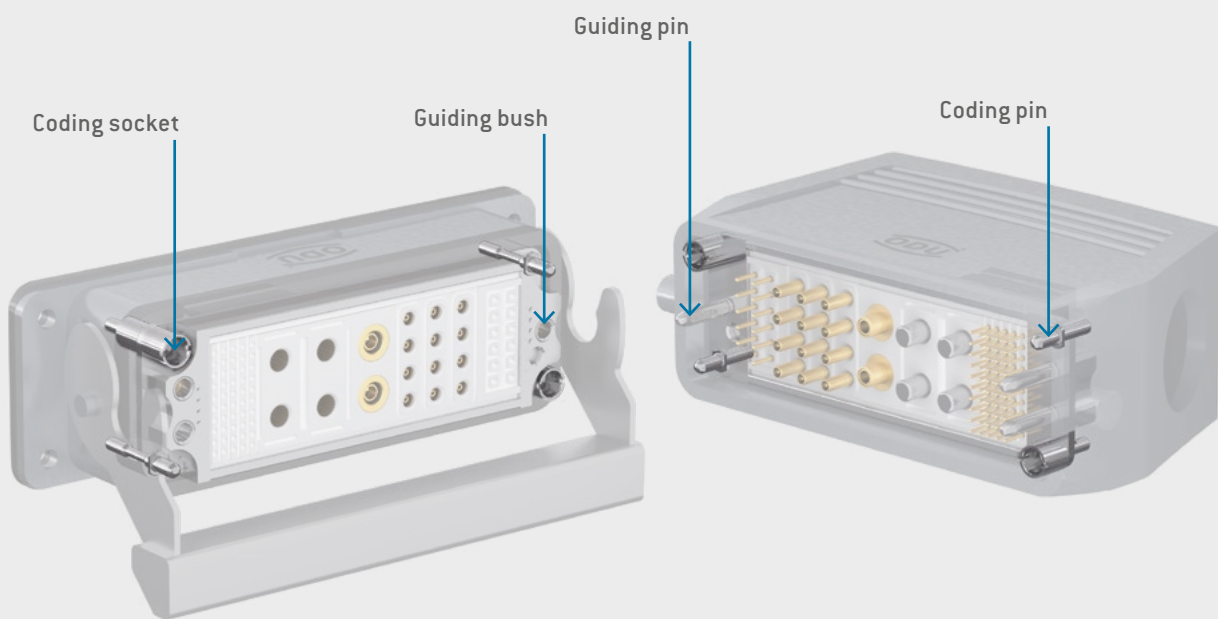
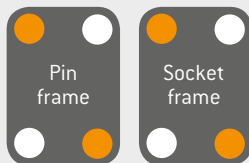

Frame	Part number matching the frame no.	Coding	
		● Part number pin	● Part number socket
Pin	611.19X.000.600.000	611.090.303.902.000 	610.090.304.902.000
Socket	610.19X.000.600.000	611.090.304.902.000 	610.090.303.902.000

PART NUMBER BASIC TOOL, SCREWDRIVER/1.2 Nm: 598.054.002.000.000
 PART NUMBER TOOL INSERT FOR CODING PIN: 598.054.203.000.000
 PART NUMBER TOOL INSERT FOR CODING SOCKET: 598.054.110.000.000

An overview of all tools is on page 176.

CODING OPTIONS FOR HOUSING WITH SPINDLE LOCKING



To prevent mismatching.

In order to prevent mismatching, it is in some cases useful to provide the connection systems with a coding system.

Instead of cylinder screws, coding pins and coding sockets can be used in the ODU-MAC in the housing. ODU offers 4 coding variations with these coding options in combination with spindle locking. Standard frames do not include additional coding upon delivery. If several adjacent connectors are used, this can prevent mismatching.



Alternatively, if additional coding options are required, ODU offers an innovative option with the coded spindle of pages [90–91](#).

CODING OPTIONS

CODE 1

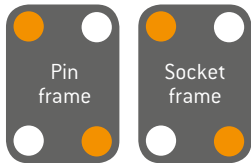

CODE 2

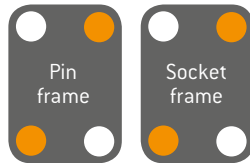

CODE 5

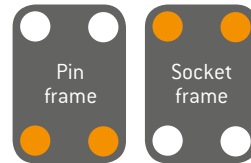

CODE 6

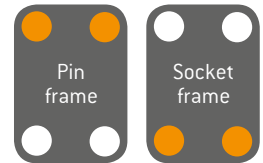

● = Coding pin

○ = Coding socket



CODING EXAMPLE

CODE 2

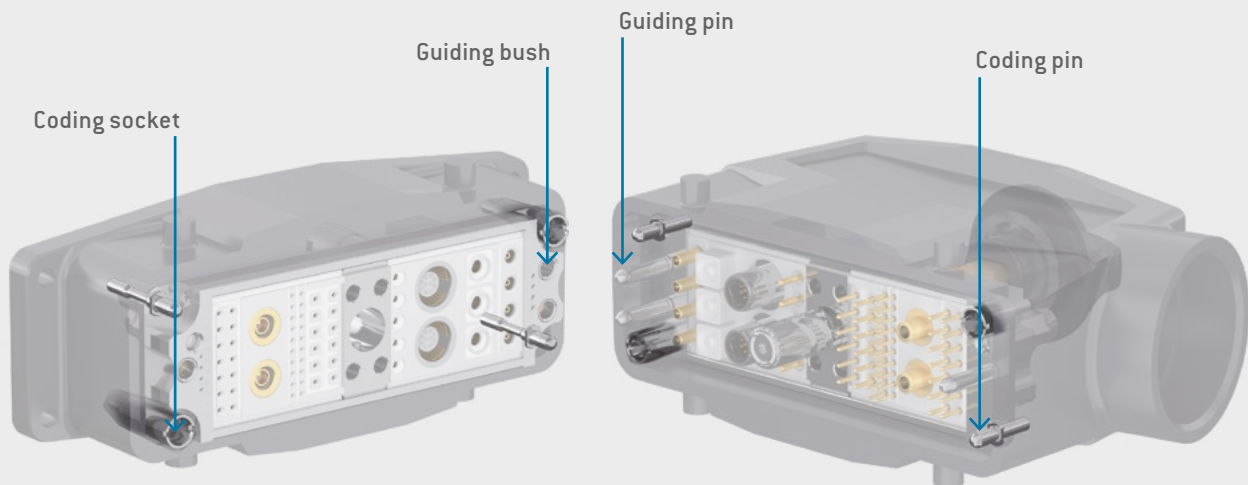
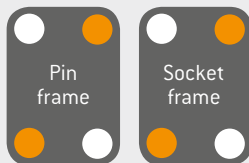

Frame	Part number matching the frame no.	Coding	
		● Part number pin	● Part number socket
Pin	611.19X.000.600.000	611.090.303.902.000 	610.090.304.902.000
Socket	610.19X.000.600.000	611.090.304.902.000 	610.090.303.902.000

PART NUMBER BASIC TOOL, TORQUE SCREWDRIVER/1.2 Nm: 598.054.002.000.000
 PART NUMBER TOOL INSERT FOR CODING PIN: 598.054.203.000.000
 PART NUMBER TOOL INSERT FOR CODING SOCKET: 598.054.110.000.000

An overview of all tools is on page 176.

CODING OPTIONS FOR CODED SPINDLE



To prevent mismatching.

In order to prevent mismatching, it is in some cases useful to provide the connection systems with a coding system.

For this purpose, ODU has developed innovative coding to provide housing variation that is directly integrated into the spindle of the ODU-MAC. ODU provides up to six different coding options with the installation of 2 keying pins in the spindle locking and 2 closure plugs in the center module. If several adjacent connectors are used, this can prevent mismatching.



Reversed gender version on request only.

CODING OPTIONS

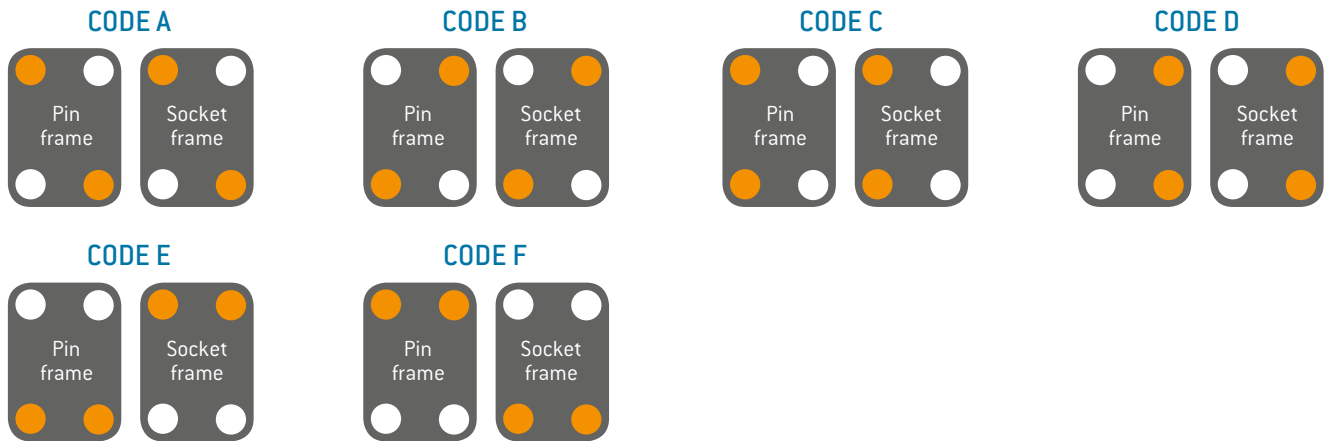

- = Keying pin
- = closure plug



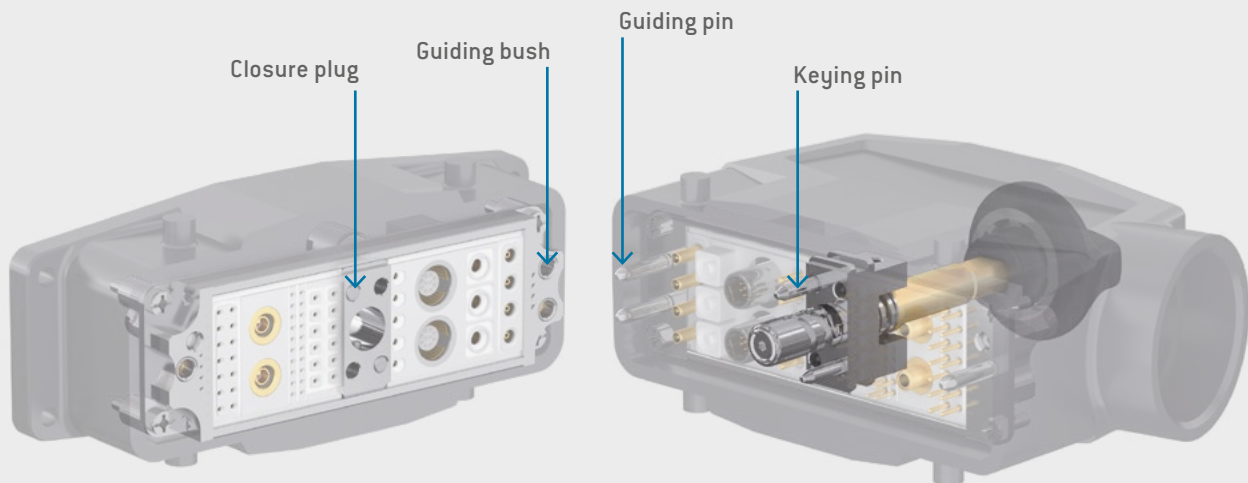
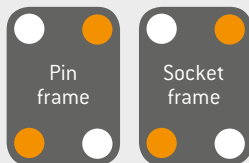

CODING EXAMPLE

CODE B



Size	WITH CODING ¹		Angle of rotation
	Part number Center module for bulkhead mounted, surface mounted housing and cable-to-cable-hoods	Part number Spindle locking for cable hoods	
2 (52 mm high)	614.090.001.304.010	615.091.003.200.010	180°
2 (72 mm high)	614.090.001.304.010	615.091.001.200.010	180°
3/4	614.090.001.304.010	615.092.021.200.013	360°
XXL	614.090.001.304.010	615.093.021.200.013	360°

¹ Keying pins and closure plugs are included as loose parts.

ONLY IF A REPLACEMENT IS REQUIRED ²	
Part number keying pin	Part number closure plug
	
615.090.107.902.000	614.090.107.902.000

² They are included in the standard scope of delivery.

TORQUE SCREWDRIVER/0.9 Nm FOR LEFT-HAND THREAD
PART NUMBER BIT SLOT FOR THE ASSEMBLY OF THE SPINDLE CODING: 598.054.109.000.000

An overview of all tools is on page [176](#).

FLEXIBLE CIRCULAR CONNECTORS WITH ODU-MAC[®] MODULES



Suitable for rugged housing from series 209 and housing ODU DOCK.

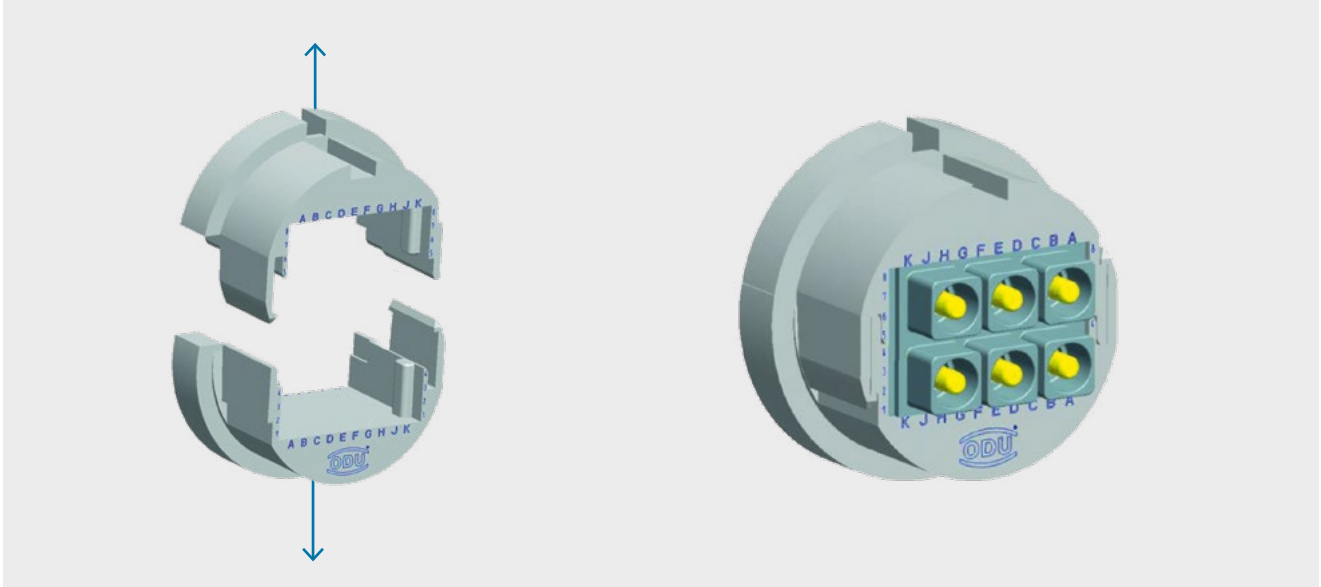

Modular circular connectors from the existing portfolio can be easily configured with the flexible ODU-MAC inserts. The flexible insulators (half shells) are compatible with the housings of the series 209 and ODU DOCK and can be easily installed in them. The result is a modular circular connector with a very robust housing.

The flexible use provides space for ODU-MAC modules with 8 units. Thanks to the divided insulator, installation of ODU-MAC modules is possible without a large expenditure of time. The modules are easily inserted into the insulator. Following the completed contact arrangement, the two halves are clipped together and integrated into the respective housing.

Due to the combination of two proven ODU products you can arrange the inserts individually:

- Combination of ODU DOCK housings with integrated modules from the ODU-MAC program
- Space for 8 units (1 unit = 2.54 mm)
- Material insulator: PBT

Description	Part number	
	Insulator socket	Insulator pin
Insulator half-shells	209.610.000.000.000	209.611.000.000.000

NOTE

- Please use only protruding contacts from $\varnothing 1.02$ mm
- Assembly instruction available on our website
- Delivery times according to series 209 and ODU DOCK



APPLICATION EXAMPLES

ODU-MAC[®]
IN ODU DOCK



ODU-MAC[®]
IN HEAVY DUTY CONNECTOR SERIES 209





CONFIGURE THE ODU-MAC®.
SIMPLY ONLINE AT WWW.ODU-MAC.COM

ODU-MAC®

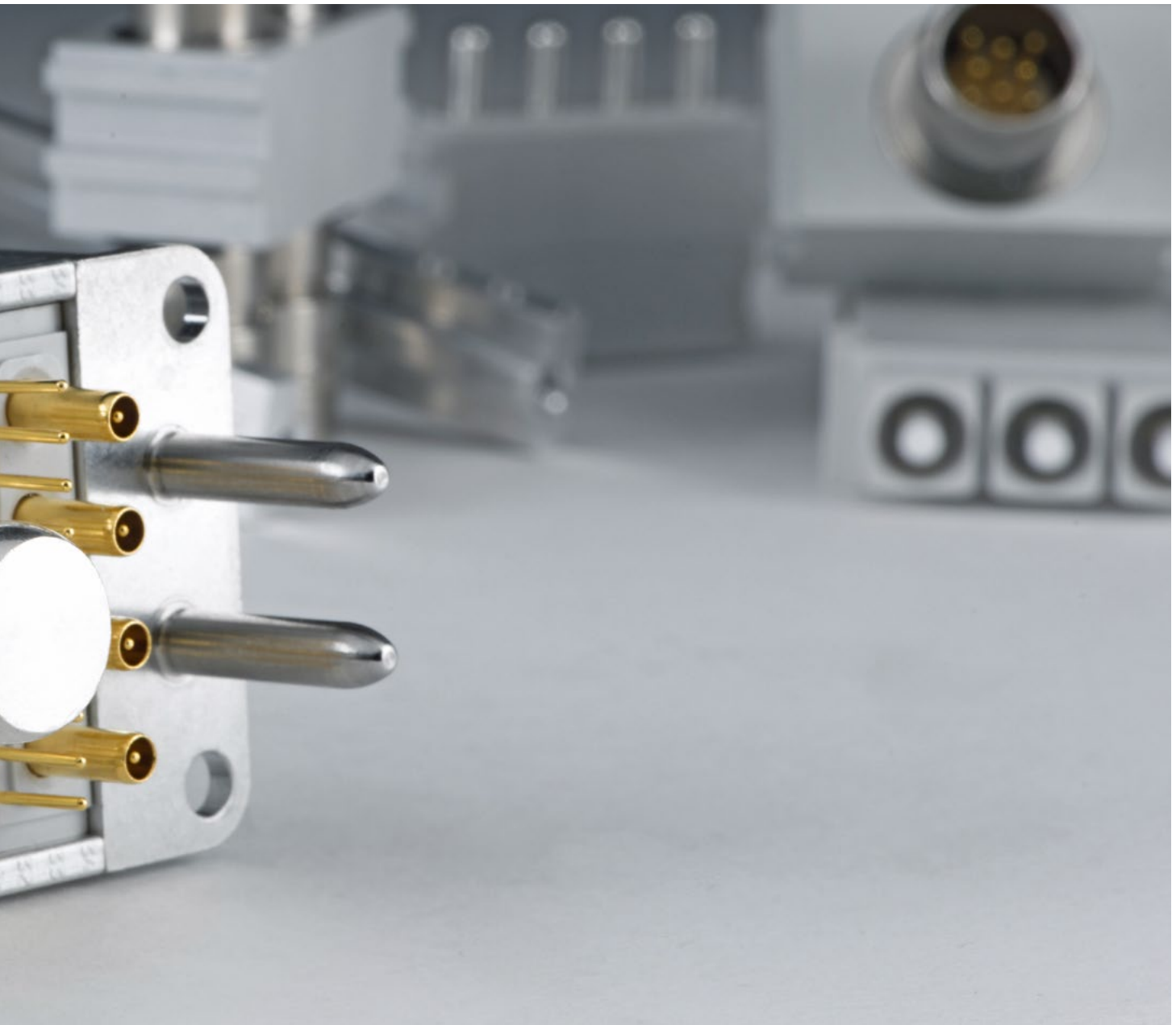

MODULES

Overview	96
Signal	102
Power	112
High current	120
High voltage	126
Coax	130
Compressed air and fluid modules	140
Fiber optic	150
Shielded implementation/high-speed connector	156
Blank modules/spacer modules/coding modules/pin protection modules	164

OVERVIEW OF ALL MODULES



Modules marked with this symbol can be used in the ODU-MAC® ZERO.

	Modules	Description	Units /width	Features	Page
Signal		14 contacts for turned contacts Contact Ø: 1.02 mm	 7.62 mm	High contact density Operating voltage ¹ 320 V Rated impulse voltage ¹ 2,500 V Max. continuous current ² 13.5 A for 0.5 mm ² Degree of pollution ¹ 2 Mating cycles minimum 100,000 	<u>102</u>
		10 contacts for turned contacts Contact Ø: 0.76 mm	 2.54 mm	Highest contact density Operating voltage ¹ 250 V Rated impulse voltage ¹ 1,500 V Max. continuous current ² 11 A for 0.38 mm ² Degree of pollution ¹ 2 Mating cycles minimum 100,000 	<u>104</u>
		10 contacts for stamped contacts Contact Ø: 0.7 mm	 2.54 mm	Economical solution Operating voltage ¹ 32 V Rated impulse voltage ¹ 1,500 V Max. continuous current ² 6 A for 0.38 mm ² Degree of pollution ¹ 2 Mating cycles minimum 5,000 	<u>106</u>
		6 contacts for turned contacts Contact Ø: 1.02 mm	 5.08 mm	Operating voltage ¹ 400 V Rated impulse voltage ¹ 3,000 V Max. continuous current ² 13.5 A for 0.5 mm ² Degree of pollution ¹ 2 Mating cycles minimum 100,000 	<u>108</u>
		5 contacts for turned contacts Contact Ø: 1.5 mm	 5.08 mm	Operating voltage ¹ 500 V Rated impulse voltage ¹ 2,500 V Max. continuous current ² 27 A for 1.5 mm ² Degree of pollution ¹ 2 Mating cycles minimum 100,000 	<u>110</u>
Power		4 contacts for turned contacts Contact Ø: 2.41 mm	 7.62 mm	Operating voltage ¹ 500 V Rated impulse voltage ¹ 3,000 V Max. continuous current ² 41 A for AWG 12 Degree of pollution ¹ 2 Mating cycles minimum 100,000 	<u>112</u>

¹Acc. to IEC 60664-1:2007 (VDE 0110-1:2008) for degree of pollution 2. ²Definition max. continuous current see page 189.

OVERVIEW OF ALL MODULES



Modules marked with this symbol can be used in the ODU-MAC® ZERO.

	Modules	Description	Units /width	Features	Page
Power		3 contacts for turned contacts Contact Ø: 3 mm	 7.62 mm	Operating voltage ¹ 500 V Rated impulse voltage ¹ 3,000 V Max. continuous current ² 58 A for 6 mm ² Degree of pollution ¹ 2 Mating cycles minimum 100,000 	114
		3 contacts for turned contacts Contact Ø: 3 mm	 10.16 mm	High voltage Operating voltage ¹ 2,500 V Rated impulse voltage ¹ 10,000 V Max. continuous current ² 58 A for 6 mm ² Degree of pollution ¹ 2 Mating cycles minimum 100,000 	116
		2 contacts for turned contacts Contact Ø: 5 mm	 12.7 mm	Operating voltage ¹ 1,000 V Rated impulse voltage ¹ 4,000 V Max. continuous current ² 119 A for 16 mm ² Degree of pollution ¹ 2 Mating cycles minimum 100,000	118
High current		2 contacts for turned contacts with ODU SPRINGTAC ³ Contact Ø: 8 mm	 15.24 mm	Operating voltage ¹ 500 V Rated impulse voltage ¹ 3,000 V Max. continuous current ² 142 A for 25 mm ² Degree of pollution ¹ 2 Mating cycles minimum 100,000	120
		2 contacts for turned contacts with ODU LAMTAC ⁴ Contact Ø: 8 mm	 15.24 mm	Operating voltage ¹ 500 V Rated impulse voltage ¹ 3,000 V Max. continuous current ² 154 A for 25 mm ² Degree of pollution ¹ 2 Mating cycles minimum 10,000	122
		1 contact for turned contacts with ODU LAMTAC ⁴ Contact Ø: 10 mm or Contact Ø: 12 mm	 17.78 mm for both versions	Highest current Model 10 mm 12 mm Operating voltage ¹ 250 V 200 V Rated impulse voltage ¹ 4,000 V 3,000 V Max. continuous current ² 179 A 220 A for 35 mm ² for 50 mm ² Degree of pollution 2 2 Mating cycles min. 10,000 min. 10,000	124

¹Acc. to IEC 60664-1:2007 (VDE 0110-1:2008). ²Definition max. continuous current see page 189. ³Contact with springwire technology. ⁴Contact with lamella technology.

OVERVIEW OF ALL MODULES

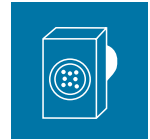

Modules marked with this symbol can be used in the ODU-MAC® ZERO.











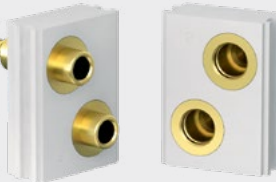

	Modules	Description	Units / width	Features	Page
High voltage		4 contacts for turned contacts Contact Ø: 1.5 mm	 7.62 mm	High contact density high voltage Operating voltage ¹ 2,500 V Rated impulse voltage ¹ 10,000 V Max. continuous current ² 27 A for 1.5 mm ² Degree of pollution ¹ 2 Mating cycles minimum 100,000	126
		1 contact Contact Ø: 2 mm	 20.32 mm	High voltage Operating voltage ¹ 6,300 V Rated impulse voltage ¹ 20,000 V Degree of pollution ¹ 2 Mating cycles minimum 10,000	128
Coax		4 contacts for 50 Ω coax contacts	 7.62 mm	High contact density Frequency range 0 to 1.3 GHz Mating cycles minimum 60,000 	130
		2 contacts for 50 Ω coax contacts SMA termination	 12.7 mm	9.0 GHz Frequency range 0 to 9.0 GHz Mating cycles minimum 100,000 	132
		2 contacts for 50 Ω coax contacts	 12.7 mm	Frequency range 0 to 2.4 GHz Mating cycles minimum 100,000 	134
		2 contacts for 50 Ω coax contacts	 12.7 mm	High voltage Frequency range 0 to 2.8 GHz Mating cycles minimum 100,000 	136

¹Acc. to IEC 60664-1:2007 (VDE 0110-1:2008) for degree of pollution 2. ²Definition max. continuous current see page 189.

OVERVIEW OF ALL MODULES

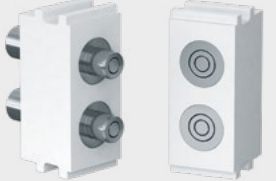

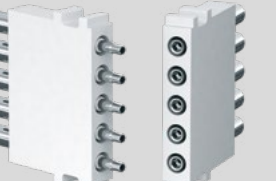
Modules marked with this symbol can be used in the ODU-MAC® ZERO.

	Modules	Description	Units / width	Features	Page	
Coax		2 contacts for 75 Ω coax contacts	 12.7 mm	Frequency range Mating cycles	0 to 3.0 GHz minimum 100,000	138
Compressed air and fluid modules		2 contacts for Compressed air valves	 12.7 mm	20 bar Tube diameter Mating cycles	M5 or max. 4 mm minimum 100,000	140
		2 contacts for Compressed air valves	 40.64 mm	12 bar Tube diameter Mating cycles	max. 6 mm minimum 100,000	142
		1 contact for Compressed air valve	 20.32 mm	12 bar Tube diameter Mating cycles	max. 6 mm minimum 100,000	144
		2 contacts for fluid coupling plug	 12.7 mm	10 bar Tube diameter Mating cycles	M5 internal thread minimum 100,000	146
Fiber optic		5 contacts for fiber optic contacts for plastic fiber (POF)	 5.08 mm	High contact density Insertion loss typical Mating cycles	1.5 dB for 670 nm minimum 40,000	150

OVERVIEW OF ALL MODULES

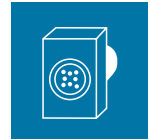

Modules marked with this symbol can be used in the ODU-MAC® ZERO.









	Modules	Description	Units / width	Features	Page
Fiber optic		2 contacts for fiber optic contacts for plastic fiber (POF)	 12.7 mm	Mating cycles minimum 100,000 Insertion loss typical 1.5 dB for 670 nm	152
		3 contacts for fiber optic contacts for fiber glass (GOF)	 10.16 mm	Mating cycles minimum 100,000 Insertion loss typical 1 dB for 670 nm	154
Shielded implementation/high-speed connector		2 to 10 contacts for inserts size 0	 12.7 mm	Mating cycles minimum 10,000 Suitable for all common bus systems USB® 1.1 ¹ , USB® 2.0 ¹ , USB® 3.1 Gen1 ¹ , FireWire® ¹ , Ethernet ¹ , CAT 5 ¹	 156
		2 to 14 contacts for inserts size 1	 15.24 mm	Mating cycles minimum 10,000 With springwire minimum 60,000 Suitable for all common bus systems USB® 2.0 ¹ , Ethernet ¹ , CAT 5 ¹	 158
		4 to 16 contacts for inserts size 2	 17.78 mm	Mating cycles minimum 10,000 With springwire minimum 60,000 Suitable for all common bus systems HDMI ¹ , Ethernet ¹ , CAT 5 ¹ , CAT 6 _A ¹	160
		10 to 30 contacts for inserts size 3	 20.32 mm	Mating cycles minimum 10,000 Suitable for all common bus systems Ethernet ¹	162

¹ Concerning data transmission protocols please note page 2.

OVERVIEW OF ALL MODULES



Modules marked with this symbol can be used in the ODU-MAC® ZERO.

	Modules	Description	Units / width	Features	Page
Blank modules / spacer modules / coding modules / pin protection modules		Blank modules	<div style="display: flex; justify-content: space-around;"> <div style="border: 1px solid black; padding: 2px; text-align: center;">1 Unit</div> <div style="border: 1px solid black; padding: 2px; text-align: center;">3 Units</div> </div> <p>2.54 mm 7.62 mm</p> <div style="border: 1px solid black; padding: 2px; text-align: center; margin: 5px auto; width: 30px;">5 Units</div> <p>12.7 mm</p>	<p>Used to fill incomplete frames.</p> 	164
		Spacer module	<div style="display: flex; justify-content: space-around;"> <div style="border: 1px solid black; padding: 2px; text-align: center;">1 Unit</div> <div style="border: 1px solid black; padding: 2px; text-align: center;">2 Units</div> </div> <p>2.54 mm 5.08 mm</p> <div style="display: flex; justify-content: space-around; margin-top: 5px;"> <div style="border: 1px solid black; padding: 2px; text-align: center;">3 Units</div> <div style="border: 1px solid black; padding: 2px; text-align: center;">5 Units</div> </div> <p>7.62 mm 12.7 mm</p>	<p>Not equipped, enable the pluggability despite different contact equipment in the pin piece.</p> <p>For information on the individual spacer modules please look at the corresponding modules.</p> 	165
		Coding modules	<div style="border: 1px solid black; padding: 2px; text-align: center; margin: 0 auto; width: 30px;">1 Unit</div> <p>2.54 mm</p>	<p>Arranged between the modules to create keyed guiding system.</p> 	166
		Pin protection modules	<div style="border: 1px solid black; padding: 2px; text-align: center; margin: 0 auto; width: 30px;">1 Unit</div> <p>2.54 mm</p>	<p>Used to protect the pins in conjunction with small pin diameters.</p> 	167

¹Concerning data transmission protocols please note page 2.

MODULES 14 CONTACTS

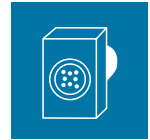

Contact diameter: 1.02 mm
Mating cycles: minimum 100,000
Current-carrying capacity¹: 13.5 A

TECHNICAL NOTES

- The current load information is valid for single contacts or fully equipped modules. For use in connector systems, the load should be reduced according to VDE 0298-4:2013 (see page 189).
- Contacts and insulators up to 200 °C on request.
- Crimp information see page 170.



Removal of the already assembled contact (incl. cable).
PART NUMBER: 087.170.362.000.000



Removal of unassembled contacts, or contacts from which the cable has been removed.
PART NUMBER: 087.611.001.001.000

For an overview of all tools please see from page 177.

TECHNICAL DATA

Voltage information²

Operating voltage	320 V	100 V
Rated impulse voltage	2,500 V	2,500 V
Degree of pollution	2	3

Voltage information acc. to MIL³

Operating voltage	950 V
Test voltage	2,850 V

Mechanical data

Total mating force (average)	18.9 N / Module
Total sliding force (average)	13.7 N / Module
Contact diameter	1.02 mm
Operating temperature	-40 °C to +125 °C
Mating cycles	minimum 100,000

Materials

Insulator	Thermoplastic fiber glass reinforced acc. to UL-94
Contact body	Cu alloy
Contact spring	CuBe alloy
Contact processing	Au over Ni

¹ Definition max. continuous current see page 189. ² IEC 60664-1:2007 (VDE 0110-1:2008) see page 183. ³ See page 187.



INSULATOR PIN AND SOCKET

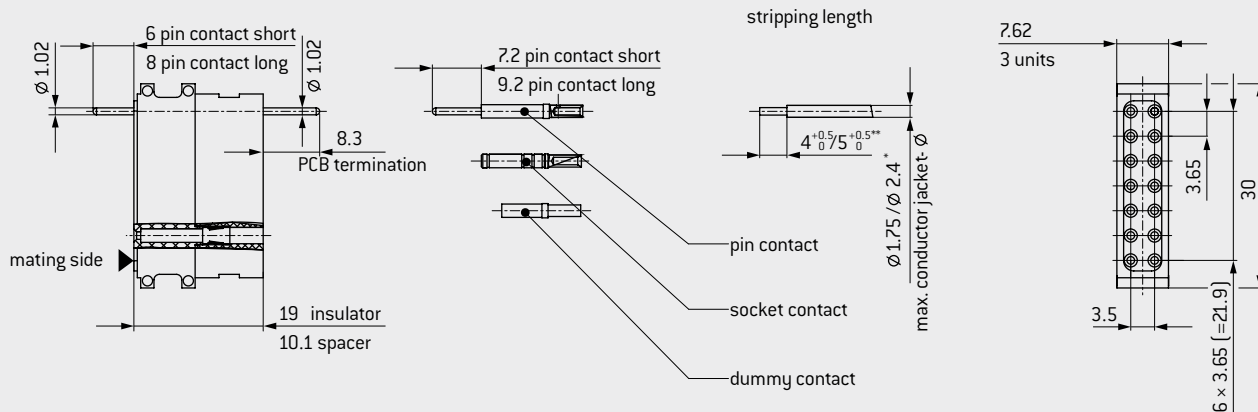

Module 14 contacts	Part number
Insulator	611.130.114.923.000
Spacer	611.130.111.923.000
Dummy contact	021.341.124.923.000

* ≤ Ø 1.75 removal possible / ≤ Ø 2.4 removal not possible.

** 4^{+0.5/-0}: AWG 24–28; 0.25–0.08 mm²

5^{+0.5/-0}: AWG 20–22; 0.5–0.38 mm²

Description	Part number	Conductor cross-section mm ²	Termination AWG/mm	Nominal current ²		Max. continuous current ³ Single contact A	Contact resistance mΩ
				Single contact A	Module fully equipped A		
Pin contact short ¹	180.362.000.307.000	0.5–0.38	20–22	9	7	13.5	2.1
Pin contact long ¹	180.382.000.307.000						
Socket contact	170.362.700.207.000						
Pin contact short ¹	180.544.000.307.000	0.25–0.08	24–28	6	5	9	2.1
Pin contact long ¹	180.574.000.307.000						
Socket contact	170.544.700.207.000						
Pin contact short ¹	180.818.000.307.000		PCB termination Ø 1.02 mm	9	7	13.5	2.1
Pin contact long ¹	180.819.000.307.000						
Socket contact	170.818.700.207.000						



¹ Non-magnetic version on request. ² Determined acc. to IEC 60512-5-1:2002 (DIN EN 60512-5-1:2003) at a temperature increase of 45 K.

³ Definition max. continuous current see page 189.

MODULE 10 CONTACTS FOR TURNED CONTACTS

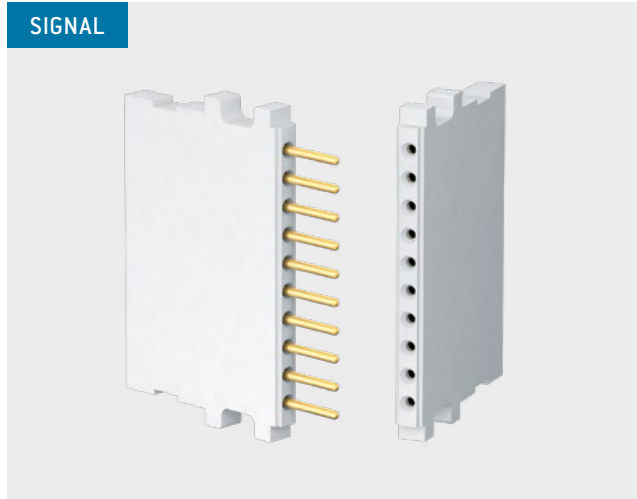
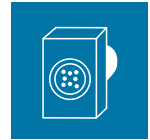

Contact diameter: 0.76 mm
Mating cycles: minimum 100,000
Current-carrying capacity¹: 11 A

TECHNICAL NOTES

- The current load information is valid for single contacts or fully equipped modules. For use in connector systems, the load should be reduced according to VDE 0298-4:2013 (see page 189).
- The 10 contacts modules with turned contacts are not compatible with stamped contacts or modules.
- Contacts and insulators up to 200 °C on request.
- Crimp information see page 170.



Removal of the already assembled contact (incl. cable).
PART NUMBER: 087.170.361.000.000



Removal of unassembled contacts, or contacts from which the cable has been removed.
PART NUMBER: 087.611.001.001.000

For an overview of all tools please see from page 177.

TECHNICAL DATA

Voltage information²

Operating voltage	250 V	32 V
Rated impulse voltage	1,500 V	1,500 V
Degree of pollution	2	3

Voltage information acc. to MIL³

Operating voltage	500 V
Test voltage	1,500 V

Mechanical data

Total mating force (average)	13.5 N / Module
Total sliding force (average)	9.8 N / Module
Contact diameter	0.76 mm
Operating temperature	-40 °C to +125 °C acc. to UL 1977, Second edition, max. 75 °C
Mating cycles	minimum 100,000

Materials

Insulator	Thermoplastic fiber glass reinforced acc. to UL-94
Contact body	Cu alloy
Contact spring	CuBe alloy
Contact processing	Au over Ni

¹ Definition max. continuous current see page 189. ² IEC 60664-1:2007 (VDE 0110-1:2008) see page 183. ³ See page 187.



INSULATOR PIN AND SOCKET

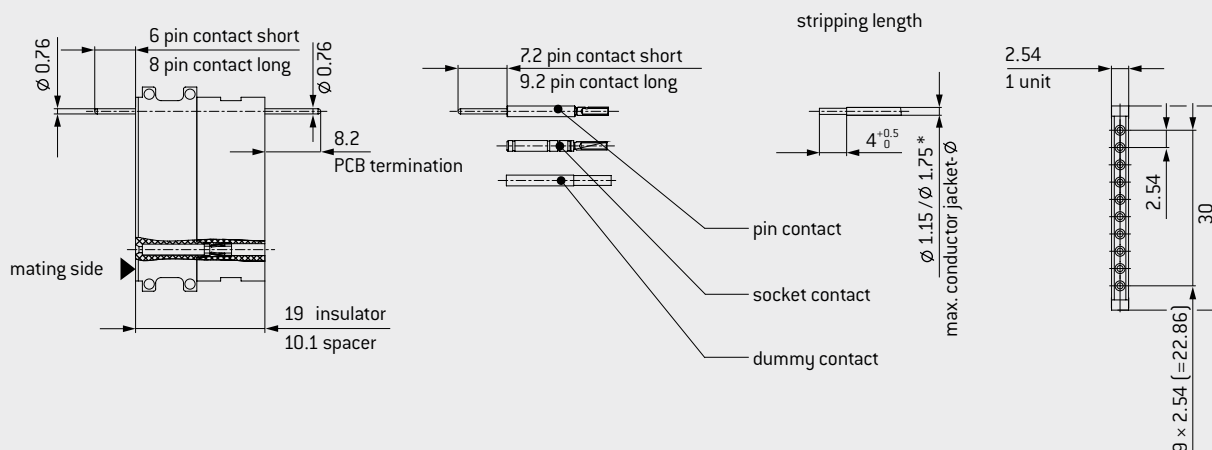

* ≤ Ø 1.15 removal possible / ≤ Ø 1.75 removal not possible.

Module 10 contacts	Part number
Insulator	611.122.110.923.000
Spacer	611.122.111.923.000
Dummy contact	021.341.123.923.000

Description	Part number	Conductor cross-section mm ²	Termination AWG/mm	Nominal current ²		Max. continuous current ³ Single contact A	Contact resistance mΩ
				Single contact A	Module fully equipped A		
Pin contact short ¹	180.361.000.307.000	0.38	22	7.5	6	11	3.8
Pin contact long ¹	180.381.000.307.000						
Socket contact ¹	170.361.700.207.000						
Pin contact short ¹	180.540.000.307.000	0.25–0.08	24 – 28	6	5	9	3.8
Pin contact long ¹	180.570.000.307.000						
Socket contact ¹	170.540.700.207.000						
Pin contact short ¹	180.850.000.307.000		PCB termination Ø 0.76 mm	7.5	6	11	3.8
Pin contact long ¹	180.851.000.307.000						
Socket contact ¹	170.850.700.207.000						



¹ Non-magnetic version on request. ² Determined acc. to IEC 60512-5-1:2002 [DIN EN 60512-5-1:2003] at a temperature increase of 45 K. ³ Definition max. continuous current see page 189.

MODULE 10 CONTACTS FOR STAMPED CONTACTS



SIGNAL

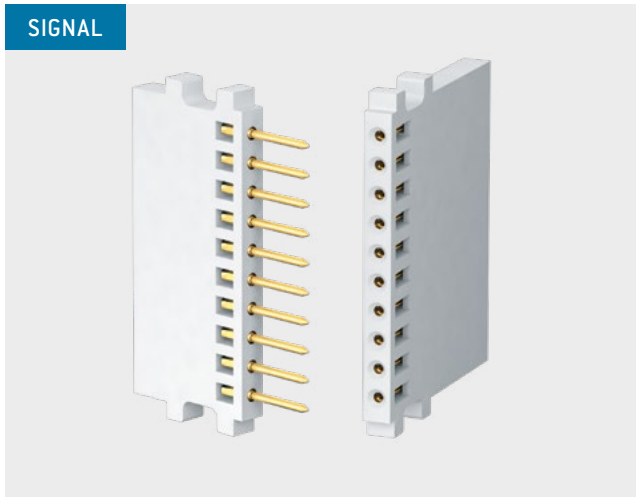

Contact diameter: 0.7 mm
Mating cycles: minimum 5,000
Current-carrying capacity¹: 6 A

TECHNICAL NOTES

- The current load information is valid for single contacts or fully equipped modules. For use in connector systems, the load should be reduced according to VDE 0298-4:2013 (see page 189).
- The 10 contacts modules with turned contacts are not compatible with stamped contacts or modules.
- Contacts are not removable.
- Crimp information see page 170.

TECHNICAL DATA

Voltage information²

Operating voltage	32 V	10 V
Rated impulse voltage	1,500 V	1,500 V
Degree of pollution	2	3

Voltage information acc. to MIL³

Operating voltage	450 V
Test voltage	1,350 V

Mechanical data

Total mating force (average)	5 N / Module
Total sliding force (average)	4.8 N / Module
Contact diameter	0.7 mm
Operating temperature	-40 °C to +125 °C
Mating cycles	minimum 5,000

Materials

Insulator	Thermoplastic fiber glass reinforced acc. to UL-94
Contact	CuSn6 alloy
Contact finish	
in termination area	Sn over Ni
in contact area	Au over Ni

¹Definition max. continuous current see page 189. ²IEC 60664-1:2007 (VDE 0110-1:2008) see page 183. ³See page 187.



INSULATOR PIN

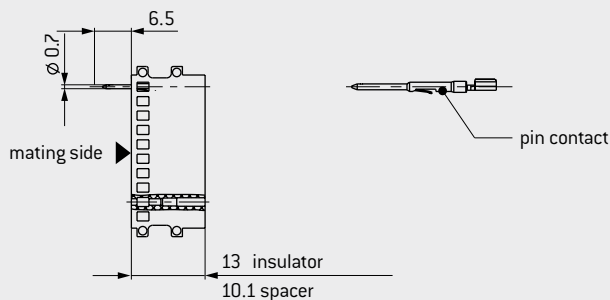

INSULATOR SOCKET

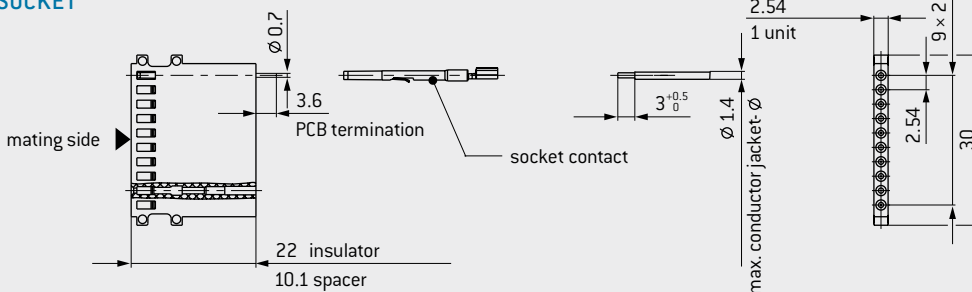

Module 10 contacts	Part number
Insulator socket (crimp)	610.158.110.923.000
Insulator pin (crimp)	611.158.110.923.000
Insulator socket (PCB equipped)	610.158.010.923.000
Spacer	611.122.111.923.000

Description	Part number	Conductor cross-section mm ²	Termination AWG	Nominal current ¹		Max. continuous current ² Single contact A	Contact resistance mΩ
				Single contact A	Module fully equipped A		
Pin contact	186.080.103.535.1__	0.14 – 0.08	26 – 28	3.5	2.5	4.5	3.8
Socket contact	176.082.103.535.1__						
Pin contact	186.080.103.535.2__	0.38 – 0.25	22 – 24	4.5	3.5	6	3.8
Socket contact	176.082.103.535.2__						

Packaging unit for crimp model (per reel)

Quantity	500	900	5,000	10,000	20,000
Code number	51	52	54	55	50

¹ Determined acc. to IEC 60512-5-1:2002 (DIN EN 60512-5-1:2003) at a temperature increase of 45 K. ² Definition max. continuous current see page 189.

MODULE 6 CONTACTS

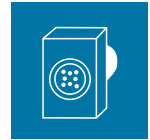

Contact diameter: 1.02 mm
Mating cycles: minimum 100,000
Current-carrying capacity¹: 13.5 A

TECHNICAL NOTES

- The current load information is valid for single contacts or fully equipped modules. For use in connector systems, the load should be reduced according to VDE 0298-4:2013 (see page 189).
- Contacts and insulators up to 200 °C on request.
- Crimp information see page 170.



Removal of the already assembled contact (incl. cable).
PART NUMBER: 087.170.362.000.000



Removal of unassembled contacts, or contacts from which the cable has been removed.
PART NUMBER: 087.611.001.001.000

For an overview of all tools please see from page 177.

TECHNICAL DATA

Voltage information²

Operating voltage	400 V	160 V
Rated impulse voltage	3,000 V	3,000 V
Degree of pollution	2	3

Voltage information acc. to MIL³

Operating voltage	850 V
Test voltage	2,550 V

Mechanical data

Total mating force (average)	8.1 N / Module
Total sliding force (average)	5.9 N / Module
Contact diameter	1.02 mm
Operating temperature	-40 °C to +125 °C
Mating cycles	minimum 100,000

Materials

Insulator	Thermoplastic fiber glass reinforced acc. to UL-94
Contact body	Cu alloy
Contact spring	CuBe alloy
Contact processing	Au over Ni

¹ Definition max. continuous current see page 189. ² IEC 60664-1:2007 (VDE 0110-1:2008) see page 183. ³ See page 187.



INSULATOR PIN AND SOCKET

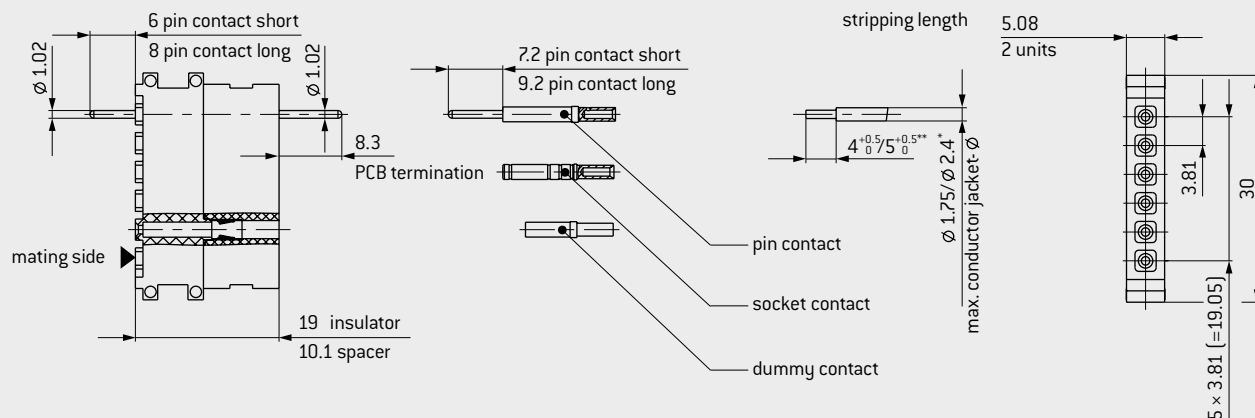

Module 6 contacts	Part number
Insulator	611.123.106.923.000
Spacer	611.123.111.923.000
Dummy contact	021.341.124.923.000

* ≤ Ø 1.75 removal possible / ≤ Ø 2.4 removal not possible.

** 4^{+0.5/0}: AWG 24 – 28; 0.25 – 0.08 mm²

5^{+0.5/0}: AWG 20 – 22; 0.5 – 0.38 mm²

Description	Part number	Conductor cross-section mm ²	Termination AWG/mm	Nominal current ²		Max. continuous current ³ Single contact A	Contact resistance mΩ
				Single contact A	Module fully equipped A		
Pin contact short ¹	180.362.000.307.000	0.5 – 0.38	20 – 22	9	8	13.5	2.1
Pin contact long ¹	180.382.000.307.000						
Socket contact ¹	170.362.700.207.000						
Pin contact short ¹	180.544.000.307.000	0.25 – 0.08	24 – 28	6	6	9	2.1
Pin contact long ¹	180.574.000.307.000						
Socket contact ¹	170.544.700.207.000						
Pin contact short ¹	180.818.000.307.000		PCB termination Ø 1.02 mm	9	8	13.5	2.1
Pin contact long ¹	180.819.000.307.000						
Socket contact ¹	170.818.700.207.000						



¹ Non-magnetic version on request. ² Determined acc. to IEC 60512-5-1:2002 (DIN EN 60512-5-1:2003) at a temperature increase of 45 K.

³ Definition max. continuous current see page 189.

MODULE 5 CONTACTS

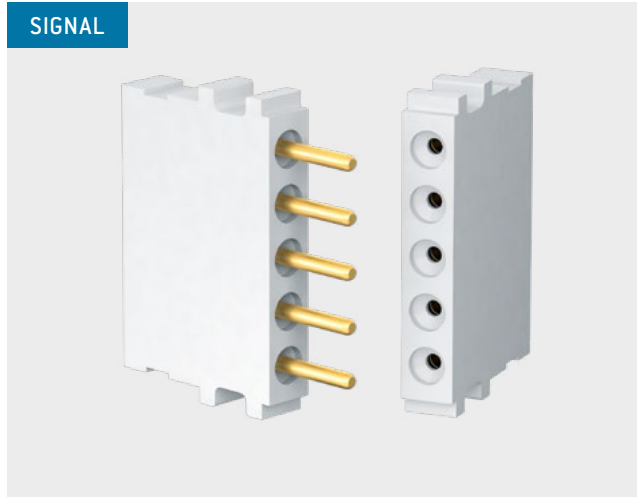
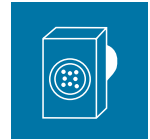

Contact diameter: 1.5 mm
Mating cycles: minimum 100,000
Current-carrying capacity¹: 27 A

TECHNICAL NOTES

- The current load information is valid for single contacts or fully equipped modules. For use in connector systems, the load should be reduced according to VDE 0298-4:2013 [see page 189].
- Contacts and insulators up to 200 °C on request.
- Crimp information see page 170.



Removal of the already assembled contact (incl. cable).
PART NUMBER: 087.170.138.000.000



Removal of the already assembled contact (incl. cable).
PART NUMBER: 087.170.363.000.000



Removal of unassembled contacts, or contacts from which the cable has been removed.
PART NUMBER: 087.611.001.001.000

For an overview of all tools please see from page 177.

TECHNICAL DATA

Voltage information²

Operating voltage	500 V	200 V
Rated impulse voltage	2,500 V	2,500 V
Degree of pollution	2	3

Voltage information acc. to MIL³

Operating voltage	750 V
Test voltage	2,250 V

Mechanical data

Total mating force (average)	15 N / Module
Total sliding force (average)	11.3 N / Module
Contact diameter	1.5 mm
Operating temperature	-40 °C to +125 °C
Mating cycles	minimum 100,000

Materials

Insulator	Thermoplastic fiber glass reinforced acc. to UL-94
Contact body	Cu alloy
Contact spring	CuSn alloy
Contact finish	
Contact body	Au over Ni
Contact springs	Ag

¹ Definition max. continuous current see page 189. ² IEC 60664-1:2007 (VDE 0110-1:2008) see page 183. ³ See page 187.



INSULATOR PIN AND SOCKET

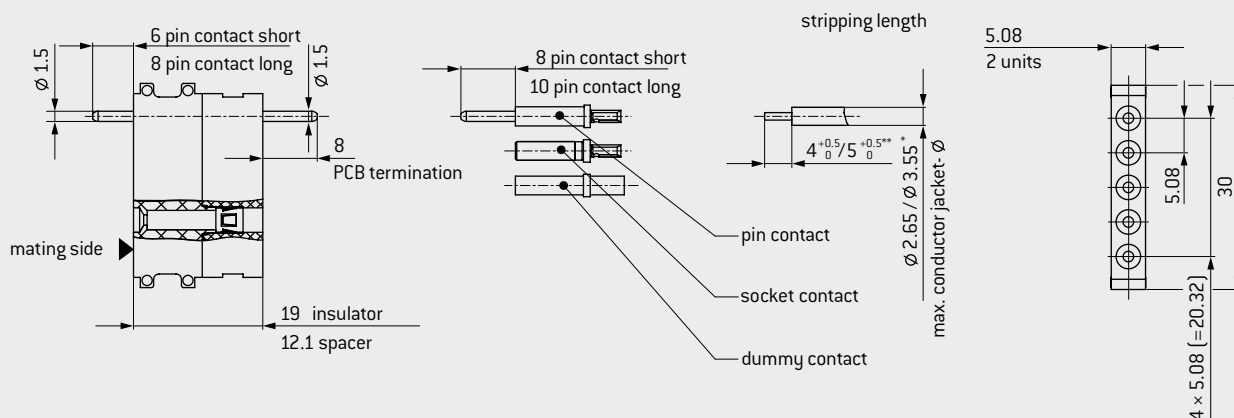

Module 5 contacts	Part number
Insulator	611.124.105.923.000
Spacer	611.124.111.923.000
Dummy contact	021.341.125.923.000

* ≤ Ø 2.65 removal possible / ≤ Ø 3.55 removal not possible.

** 4^{+0.5}/₀: AWG 24–28; 0.25–0.08 mm²

5^{+0.5}/₀: AWG 20–22; 0.5–0.38 mm²
 AWG 14–18; 0.75–1.5 mm²

Description	Part number	Conductor cross-section mm ²	Termination AWG/mm	Nominal current ²		Max. continuous current ³ Single contact A	Contact resistance mΩ
				Single contact A	Module fully equipped A		
Pin contact short ¹	180.363.000.307.000	1.5	14	18	14.5	27	0.95
Pin contact long ¹	180.383.000.307.000						
Socket contact ¹	170.363.700.201.000						
Pin contact short	180.543.000.307.000	1 – 0.75	16	18	14.5	27	0.95
Pin contact long	180.573.000.307.000						
Socket contact	170.543.700.201.000						
Pin contact short ¹	180.545.000.307.000	0.5 – 0.38	18	16	13	22.5	0.95
Pin contact long ¹	180.575.000.307.000						
Socket contact ¹	170.545.700.201.000						
Pin contact short ¹	180.541.000.307.000	0.25 – 0.08	20 – 22	10	8	15	0.95
Pin contact long ¹	180.571.000.307.000						
Socket contact ¹	170.541.700.201.000						
Pin contact short	180.857.000.307.000	0.25 – 0.08	24 – 28	6	6	9	0.95
Pin contact long	180.856.000.307.000						
Socket contact	170.857.700.201.000						
Pin contact short	180.539.000.307.000	PCB termination Ø 1.5 mm	PCB termination Ø 1.5 mm	18	14.5	27	0.95
Pin contact long	180.569.000.307.000						
Socket contact	170.539.700.201.000						



¹ Non-magnetic version on request. ² Determined acc. to IEC 60512-5-1:2002 (DIN EN 60512-5-1:2003) at a temperature increase of 45 K.

³ Definition max. continuous current see page 189.

MODULE 4 CONTACTS



Contact diameter: 2.41 mm
Mating cycles: minimum 100,000
Current-carrying capacity¹: 41 A



Removal of the already assembled contact (incl. cable).
PART NUMBER: 087.170.139.000.000



Removal of the already assembled contact (incl. cable).
PART NUMBER: 087.170.365.000.000



Removal of unassembled contacts, or contacts from which the cable has been removed.
PART NUMBER: 087.611.001.001.000

For an overview of all tools please see from page [177](#).

TECHNICAL NOTES

- The current load information is valid for single contacts or fully equipped modules. For use in connector systems, the load should be reduced according to VDE 0298-4:2013 (see page [189](#)).
- Crimp information see page [170](#).

TECHNICAL DATA

Voltage information²

Operating voltage	500 V	200 V
Rated impulse voltage	3,000 V	3,000 V
Degree of pollution	2	3

Voltage information acc. to MIL³

Operating voltage	1,100 V
Test voltage	3,300 V

Mechanical data

Total mating force (average)	13 N / Module
Total sliding force (average)	12 N / Module
Contact diameter	2.41 mm
Operating temperature	-40 °C to +125 °C
Mating cycles	minimum 100,000

Materials

Insulator	Thermoplastic fiber glass reinforced acc. to UL-94
Contact body	Cu alloy
Contact spring	CuSn alloy
Contact finish	Ag

¹ Definition max. continuous current see page [189](#). ² IEC 60664-1:2007 (VDE 0110-1:2008) see page [183](#). ³ See page [187](#).



INSULATOR PIN AND SOCKET

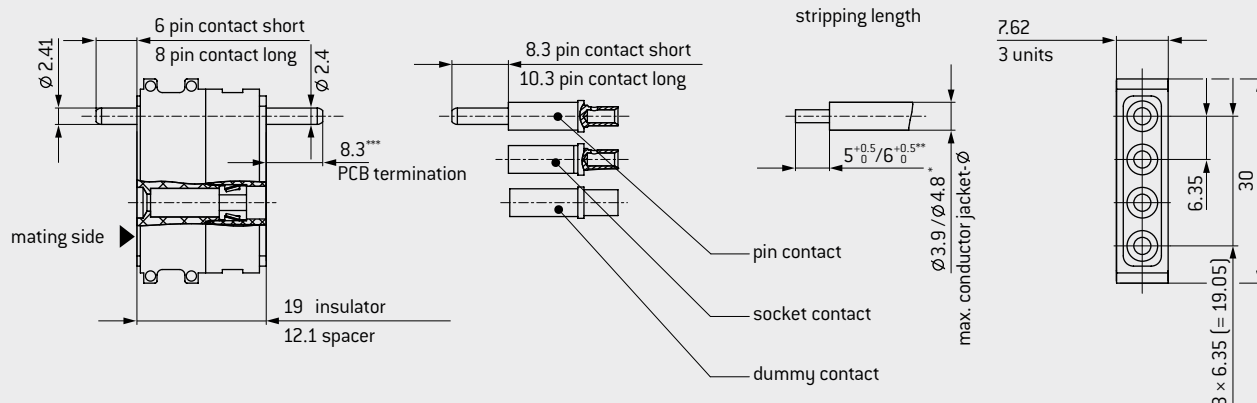

Module 4 contacts	Part number
Insulator	611.126.104.923.000
Spacer	611.126.111.923.000
Dummy contact	021.341.127.923.000

* ≤ Ø 3.9 removal possible / ≤ Ø 4.8 removal not possible.

** 5^{+0.5}: AWG 14 – 22; 0.38 – 1.5 mm²

6^{+0.5}: AWG 12; 2.5 mm²

*** PCB termination / crimp termination at 6 mm², protection against contact in the termination area recommended, e. g. heat-shrink tubing.

Description	Part number	Conductor cross-section mm ²	Termination AWG/mm	Nominal current ²		Max. continuous current ³ Single contact A	Contact resistance mΩ
				Single contact A	Module fully equipped A		
Pin contact short	180.365.000.301.000	2.5	12	28	25	41	0.45
Pin contact long	180.385.000.301.000						
Socket contact	170.365.100.201.000						
Pin contact short ¹	180.910.000.301.000	1.5	14	18	15	27	0.45
Pin contact long ¹	180.911.000.301.000						
Socket contact ¹	170.910.100.201.000						
Pin contact short	182.607.000.301.000	1 – 0.75	18	16	13	23.5	0.45
Pin contact long	182.604.000.301.000						
Socket contact	172.604.100.201.000						
Pin contact short	182.606.000.301.000	0.5 – 0.38	20 – 22	10.5	8	15.5	0.55
Pin contact long	182.605.000.301.000						
Socket contact	172.605.100.201.000						
Pin contact short	180.820.000.301.000	PCB termination Ø 2.4 mm	28	25	25	41	0.45
Pin contact long	180.821.000.301.000						
Socket contact	170.820.100.201.000						



¹ Non-magnetic version on request. ² Determined acc. to IEC 60512-5-1:2002 (DIN EN 60512-5-1:2003) at a temperature increase of 45 K.

³ Definition max. continuous current see page 189.

MODULE 3 CONTACTS

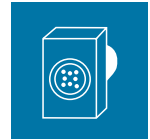

Contact diameter: 3 mm
Mating cycles: minimum 100,000
Termination cross-section: from 0.38 to 6 mm²

TECHNICAL NOTES

- The current load information is valid for single contacts or fully equipped modules. For use in connector systems, the load should be reduced according to VDE 0298-4:2013 (see page 189).
- Crimp information see page 170.

TECHNICAL DATA

Voltage information¹

Operating voltage	500 V	200 V
Rated impulse voltage	3,000 V	3,000 V
Degree of pollution	2	3

Voltage information acc. to MIL²

Operating voltage	1,200 V
Test voltage	3,600 V

Mechanical data

Total mating force (average)	13.5 N / Module
Total sliding force (average)	9.8 N / Module
Contact diameter	3 mm
Operating temperature	-40 °C to +125 °C
Mating cycles	minimum 100,000

Materials

Insulator	Thermoplastic fiber glass reinforced acc. to UL-94
Contact body	Cu alloy
Contact spring	CuSn alloy
Contact finish	Ag



Removal of the already assembled contact (incl. cable).
PART NUMBER: 087.170.136.000.000



Removal of the already assembled contact (incl. cable).
PART NUMBER: 087.170.366.000.000



Removal of unassembled contacts, or contacts from which the cable has been removed.
PART NUMBER: 087.611.001.001.000

For an overview of all tools please see from page 177.

¹ IEC 60664-1:2007 (VDE 0110-1:2008) see page 183. ² See page 187.



INSULATOR PIN AND SOCKET

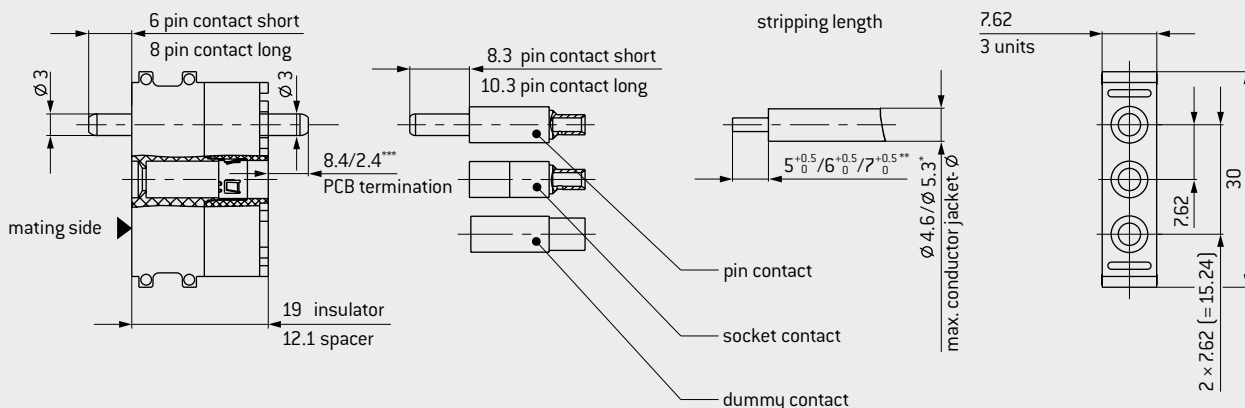

* ≤ Ø 4.6 removal possible / ≤ Ø 5.3 removal not possible.

** $5_{0}^{+0.5}$: AWG 14/22; 0.38–4 mm²

$6_{0}^{+0.5}$: 2.5–4 mm²

$7_{0}^{+0.5}$: 6 mm²

*** PCB termination / crimp termination at 6 mm², protection against contact in the termination area recommended, e. g. heat-shrink tubing.

Module 3 contacts	Part number
Insulator	611.127.103.923.000
Spacer	611.127.111.923.000
Dummy contact	021.341.128.923.000

Description	Part number	Conductor cross-section mm ²	Termination AWG/mm	Nominal current ²		Max. continuous current ³ Single contact A	Contact resistance mΩ
				Single contact A	Module fully equipped A		
Pin contact short	182.980.000.301.000	6		39	30	58	0.3
Pin contact long	182.981.000.301.000						
Socket contact	172.978.100.201.000						
Pin contact short ¹	180.366.000.301.000	4		39	30	58	0.3
Pin contact long ¹	180.386.000.301.000						
Socket contact ¹	172.366.100.201.000						
Pin contact short	180.546.000.301.000	2.5		25	21	37	0.3
Pin contact long	180.576.000.301.000						
Socket contact	170.546.100.201.000						
Pin contact short ¹	182.582.000.301.000	1.5	14	19	16	28	1
Pin contact long	182.583.000.301.000						
Socket contact ¹	172.582.100.201.000						
Pin contact short	182.584.000.301.000	1–0.75	18	16.5	14	24.5	1
Pin contact long ¹	182.585.000.301.000						
Socket contact ¹	172.584.100.201.000						
Pin contact short	182.586.000.301.000	0.5–0.38	20–22	11.5	9.5	17	0.4
Pin contact long	182.587.000.301.000						
Socket contact	172.586.100.201.000						
Pin contact short	182.571.000.301.000		PCB termination Ø 3.0 mm	39	30	58	0.3
Pin contact long	182.572.000.301.000						
Socket contact	172.843.100.201.000						



¹ Non-magnetic version on request. ² Determined acc. to IEC 60512-5-1:2002 (DIN EN 60512-5-1:2003) at a temperature increase of 45 K.

³ Definition max. continuous current see page 189.

MODULE 3 CONTACTS

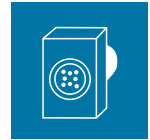

Contact diameter: 3 mm
Mating cycles: minimum 100,000
Current-carrying capacity¹: 58 A

TECHNICAL NOTES

- The current load information is valid for single contacts or fully equipped modules. For use in connector systems, the load should be reduced according to VDE 0298-4:2013 (see page [189](#)).
- Crimp information see page [170](#).



Removal of the already assembled contact (incl. cable).
PART NUMBER: 087.170.136.000.000



Removal of unassembled contacts, or contacts from which the cable has been removed.
PART NUMBER: 087.611.001.001.000

For an overview of all tools please see from page [177](#).

TECHNICAL DATA

Voltage information²

Operating voltage	2,500 V	1,000 V
Rated impulse voltage	10,000 V	8,000 V
Degree of pollution	2	3

Voltage information acc. to MIL³

Operating voltage	2,500 V
Test voltage	7,500 V

Mechanical data

Total mating force (average)	13.5 N / Module
Total sliding force (average)	9.8 N / Module
Contact diameter	3 mm
Operating temperature	-40 °C to +125 °C acc. to UL 1977, Second Edition, max. 75 °C
Mating cycles	minimum 100,000

Materials

Insulator	Thermoplastic fiber glass reinforced acc. to UL-94
Contact body	Cu alloy
Contact spring	CuSn alloy
Contact finish	Ag

¹ Definition max. continuous current see page [189](#). ² IEC 60664-1:2007 (VDE 0110-1:2008) see page [183](#). ³ See page [187](#).



INSULATOR PIN

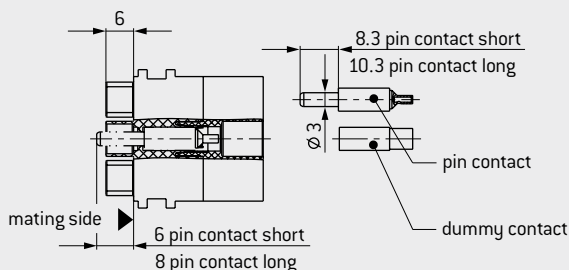

INSULATOR SOCKET

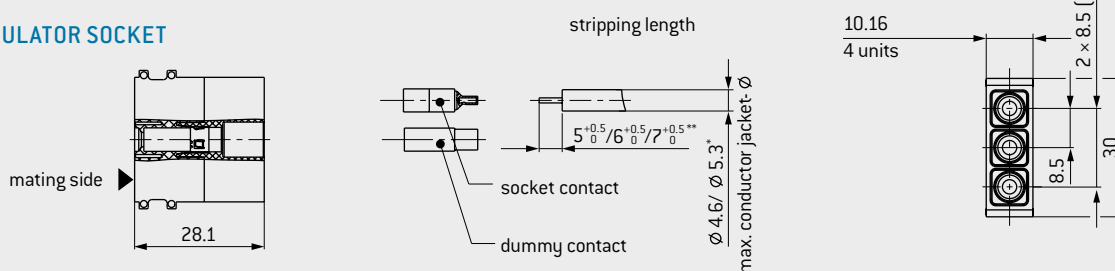

Module 3 contacts	Part number
Insulator socket	610.162.103.923.000
Insulator pin	611.162.103.923.000
Dummy contact	021.341.128.923.000

* ≤ Ø 4.6 removal possible / ≤ Ø 5.3 removal not possible.

** $5_{0}^{+0.5}$: AWG 14–22; 0.38–4 mm²

$6_{0}^{+0.5}$: 2.5–4 mm²

$7_{0}^{+0.5}$: 6 mm²

Description	Part number	Conductor cross-section mm ²	Termination AWG	Nominal current ²		Max. continuous current ³ Single contact A	Contact resistance mΩ
				Single contact A	Module fully equipped A		
Pin contact	182.980.000.301.000	6		39	30	58	0.3
Pin contact long	182.981.000.301.000						
Socket contact	172.978.100.201.000						
Pin contact short ¹	180.366.000.301.000	4		39	30	58	0.3
Pin contact long ¹	180.386.000.301.000						
Socket contact ¹	172.366.100.201.000						
Pin contact short	180.546.000.301.000	2.5		25	21	37	0.3
Pin contact long	180.576.000.301.000						
Socket contact	170.546.100.201.000						
Pin contact short ¹	182.582.000.301.000	1.5	14	19	16	28	1
Pin contact long	182.583.000.301.000						
Socket contact ¹	172.582.100.201.000						
Pin contact short	182.584.000.301.000	1–0.75	18	16.5	14	24.5	1
Pin contact long ¹	182.585.000.301.000						
Socket contact ¹	172.584.100.201.000						
Pin contact short	182.586.000.301.000	0.5–0.38	20–22	11.5	9.5	17	1
Pin contact long	182.587.000.301.000						
Socket contact	172.586.100.201.000						



¹ Non-magnetic version on request. ² Determined acc. to IEC 60512-5-1:2002 (DIN EN 60512-5-1:2003) at a temperature increase of 45 K.

³ Definition max. continuous current see page 189.

MODULE 2 CONTACTS

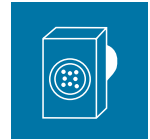

Removal of the already assembled contact (incl. cable).
PART NUMBER: 087.170.391.000.000

For an overview of all tools please see from page [177](#).

Contact diameter: 5 mm
Mating cycles: minimum 100,000
Current-carrying capacity¹: 119 A

TECHNICAL NOTES

- The current load information is valid for single contacts or fully equipped modules. For use in connector systems, the load should be reduced according to VDE 0298-4:2013 (see page [189](#)).
- When automatic docking due to the high mating forces and the high cable cross sections we recommend the assembly in the ODU-MAC P+ [Power] frame (see page [41](#)).
- Crimp information see page [170](#).
- Contacts and insulators up to 200 °C on request.

TECHNICAL DATA

Voltage information²

Operating voltage	1,000 V	250 V
Rated impulse voltage	4,000 V	4,000 V
Degree of pollution	2	3

Voltage information acc. to MIL³

Operating voltage	1,250 V
Test voltage	3,750 V

Mechanical data

Total mating force (average)	21 N / Module
Total sliding force (average)	15 N / Module
Contact diameter	5 mm
Operating temperature	-40 °C to +125 °C
Mating cycles	minimum 100,000

Materials

Insulator	Thermoplastic fiber glass reinforced acc. to UL-94
Contact body	Cu alloy
Contact spring	CuSn alloy
Contact finish	Ag

¹Definition max. continuous current see page [189](#). ²IEC 60664-1:2007 (VDE 0110-1:2008) see page [183](#). ³See page [187](#).



INSULATOR PIN AND SOCKET

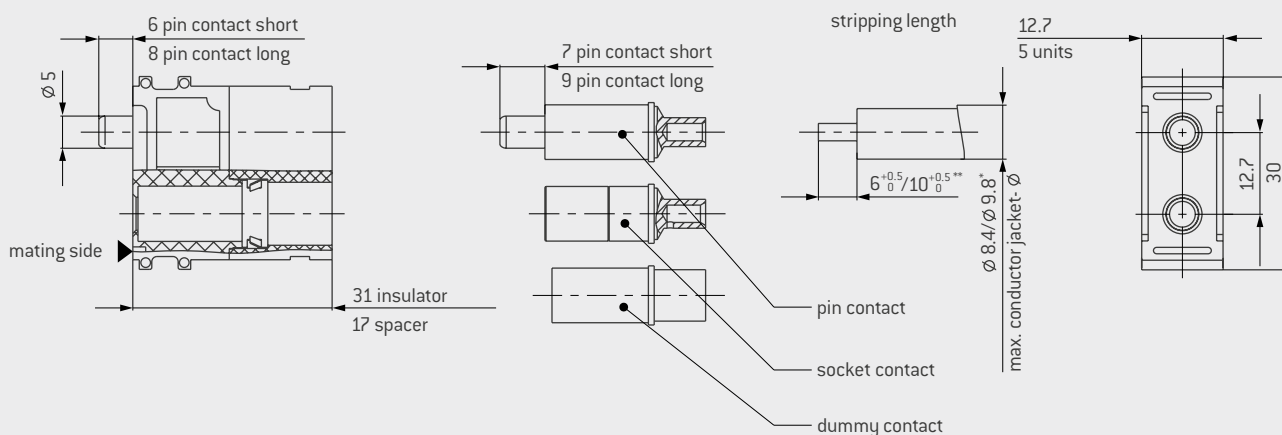

Module 2 contacts	Part number
Insulator	611.129.102.923.000
Spacer	611.129.111.923.000
Dummy contact	021.341.130.923.000

* ≤ Ø 8.4 removal possible / ≤ Ø 9.8 removal not possible.

** 6^{+0.5}/₀: 4 mm²
10^{+0.5}/₀: 10–16 mm²

Description	Part number	Conductor cross-section mm ²	Nominal current ¹		Max. continuous current ² Single contact A	Contact resistance mΩ
			Single contact A	Module fully equipped A		
Pin contact short	182.891.000.301.000	16	80	70	119	0.21
Pin contact long	182.892.000.301.000					
Socket contact	172.891.100.201.000					
Pin contact short	180.490.000.301.000	10	65	57	97	0.21
Pin contact long	180.491.000.301.000					
Socket contact	170.490.100.201.000					
Pin contact short	180.369.000.301.000	4	39	34	58	0.21
Pin contact long	180.389.000.301.000					
Socket contact	170.369.100.201.000					

¹ Determined acc. to IEC 60512-5-1:2002 (DIN EN 60512-5-1:2003) at a temperature increase of 45 K. ² Definition max. continuous current see page 189.

MODULE 2 CONTACTS

ODU SPRINGTAC[®] (contacts with springwire technology).

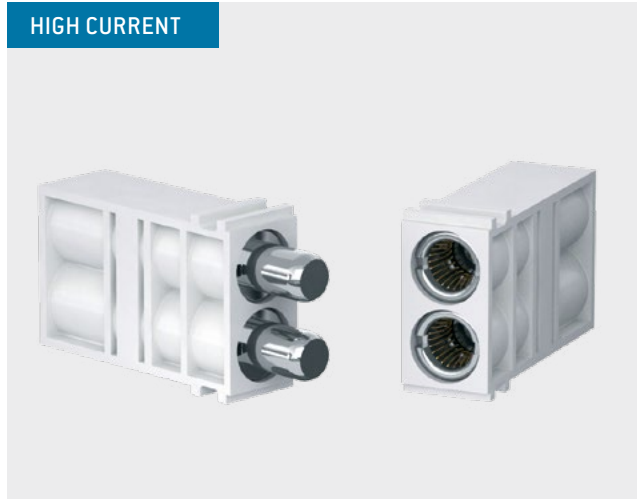
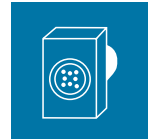

Contact diameter: 8 mm
Mating cycles¹: minimum 100,000
Current-carrying capacity²: 142 A

TECHNICAL NOTES

- The current load information is valid for single contacts or fully equipped modules. For use in connector systems, the load should be reduced according to VDE 0298-4:2013 (see page 189).
- When automatic docking due to the high mating forces and the high cable cross sections we recommend the assembly in the ODU-MAC P+ (Power) frame (see page 45).
- Crimp information see page 170.

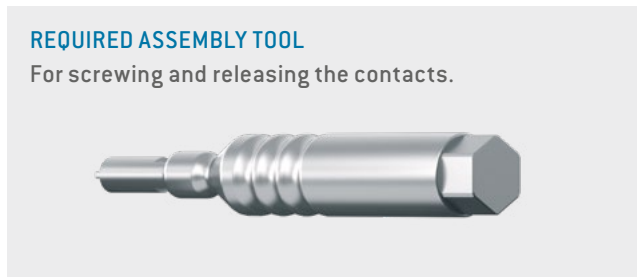

PART NUMBER: 087.611.002.001.000

Locking torque: 2.7 Nm ± 0.1 Nm

For an overview of all tools please see from page 177.

TECHNICAL DATA

Voltage information³

Operating voltage	500 V	200 V
Rated impulse voltage	3,000 V	3,000 V
Degree of pollution	2	3

Voltage information acc. to MIL⁴

Operating voltage	700 V
Test voltage	2,100 V

Mechanical data

Total mating force (average)	54 N / Module
Total sliding force (average)	39 N / Module
Contact diameter	8 mm
Operating temperature	-40 °C to +125 °C
Mating cycles ¹	minimum 100,000

Materials

Insulator	Thermoplastic fiber glass reinforced acc. to UL-94
Contact body	Cu alloy
Contact spring	CuSn alloy
Contact finish	Ag

¹ Higher mating cycles by easy exchange of the wear parts (pin/socket from front) possible. The termination area remains unaffected, because of two-part contact.
² Definition max. continuous current see page 189. ³ IEC 60664-1:2007 (VDE 0110-1:2008) see page 183. ⁴ See page 187.



INSULATOR PIN AND SOCKET

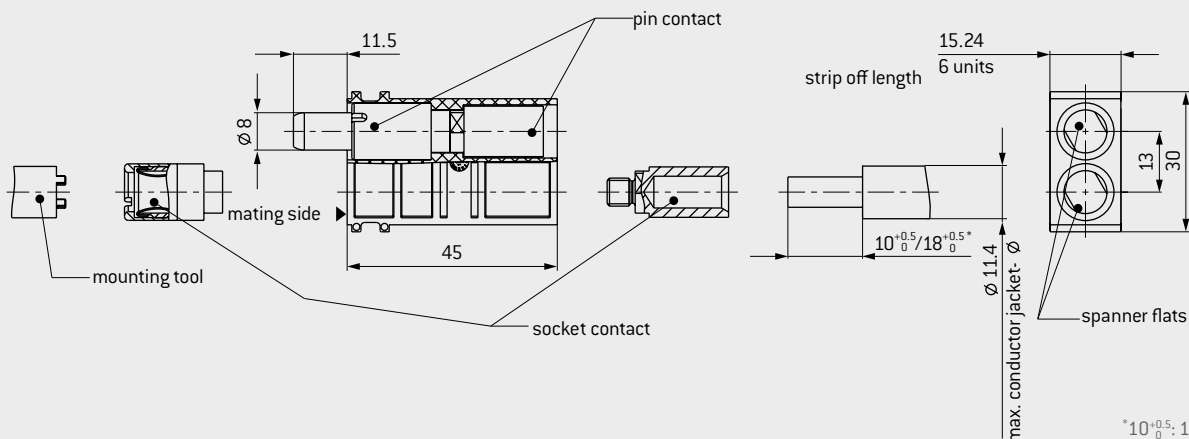

In application with a housing please check the cable space requirement.

*10^{+0.5}/₀: 16 mm²
18^{+0.5}/₀: 25 mm²

ODU SPRINGTAC® (CONTACTS WITH SPRINGWIRE TECHNOLOGY)

ODU SPRINGTAC offers a large number of contact surfaces. The wires are mounted individually and connected with a lathe-turned body. The springwires contact and flex independently from one another (see also page 30).

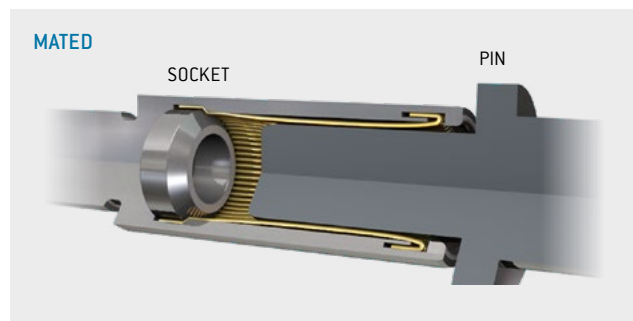
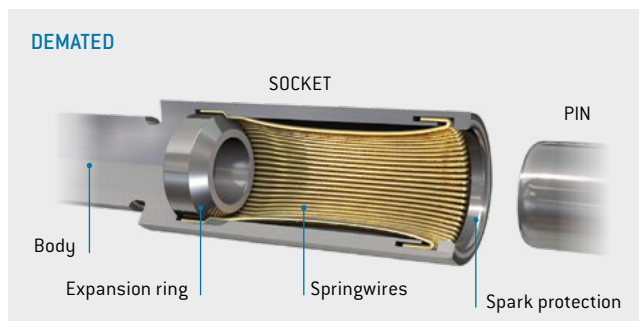

Module 2 contacts	Part number
Insulator	611.173.102.923.000

Description	Part number	Conductor cross-section ¹ mm ²	Nominal current ²		Max. continuous current ³ Single contact A	Contact resistance mΩ
			Single contact A	Module fully equipped A		
Pin contact	181.873.100.200.000	25	100	95	142	0.2
Socket contact	170.045.100.201.000					
Pin contact	181.872.100.200.000	16	75	70	111	0.2
Socket contact	171.045.100.201.000					

¹Extra fine wire acc. to IEC 60228:2004 (VDE 0295:2005; class 5), class 5. ²Determined acc. to IEC 60512-5-1:2002 (DIN EN 60512-5-1:2003) at a temperature increase of 45 K. ³Definition max. continuous current see page 189.

MODULE 2 CONTACTS



ODU LAMTAC® (contacts with lamella technology).

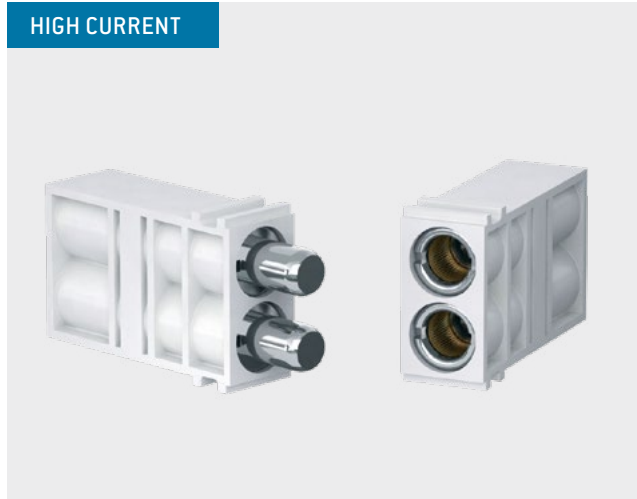

Contact diameter: 8 mm
Mating cycles¹: minimum 10,000
Current-carrying capacity²: 154 A

TECHNICAL NOTES

- The current load information is valid for single contacts or fully equipped modules. For use in connector systems, the load should be reduced according to VDE 0298-4:2013 (see page 189).
- When automatic docking due to the high mating forces and the high cable cross sections we recommend the assembly in the ODU-MAC P+ [Power] frame (see page 45).
- Crimp information see page 170.



PART NUMBER: 087.611.002.001.000

Locking torque: 2.7 Nm ± 0.1 Nm

For an overview of all tools please see from page 177.

TECHNICAL DATA

Voltage information³

Operating voltage	500 V	200 V
Rated impulse voltage	3,000 V	3,000 V
Degree of pollution	2	3

Voltage information acc. to MIL⁴

Operating voltage	900 V
Test voltage	2,700 V

Mechanical data

Total mating force (average)	60 N / Module
Total sliding force (average)	45 N / Module
Contact diameter	8 mm
Operating temperature	-40 °C to +125 °C
Mating cycles	minimum 10,000

Materials

Insulator	Thermoplastic fiber glass reinforced acc. to UL-94
Contact body	Cu alloy
Contact lamella	CuBe alloy
Contact finish	Ag

¹ Higher mating cycles by easy exchange of the wear parts (pin/socket from front) possible. The termination area remains unaffected, because of two-part contact.
² Definition max. continuous current see page 189. ³ IEC 60664-1:2007 (VDE 0110-1:2008) see page 183. ⁴ See page 187.



INSULATOR PIN AND SOCKET

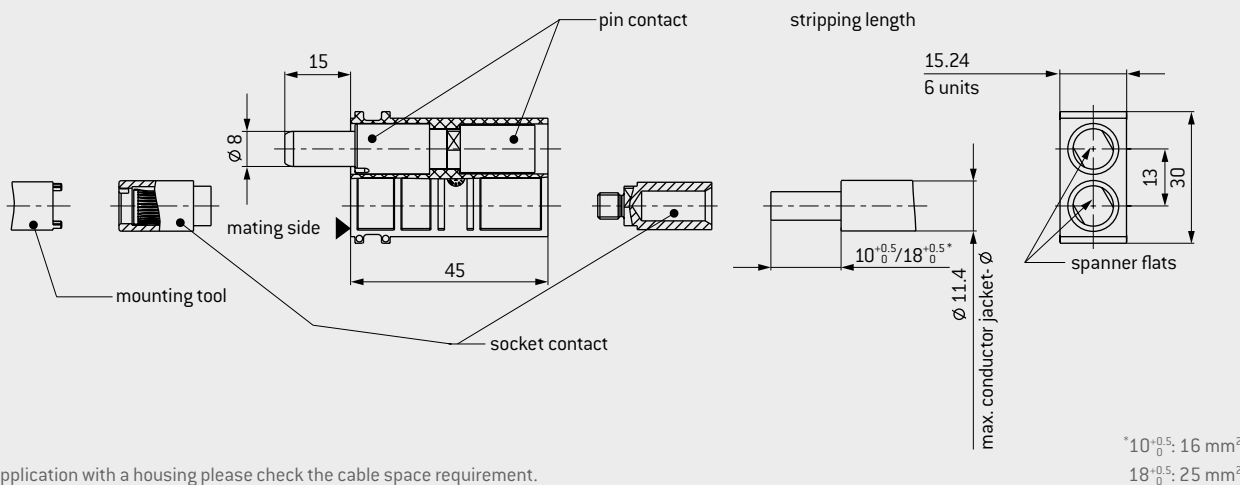

ODU LAMTAC® (CONTACTS WITH LAMELLA TECHNOLOGY)

In comparison to the ODU SPRINGTAC contact, ODU LAMTAC offers a lower number of contact surfaces. One or more of the stamped lamellas are mounted in a lathe-turned body (see also page 31).

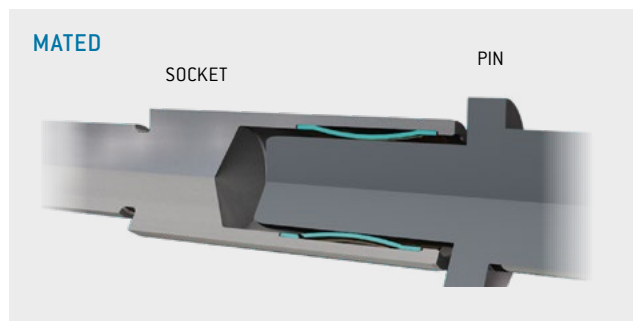
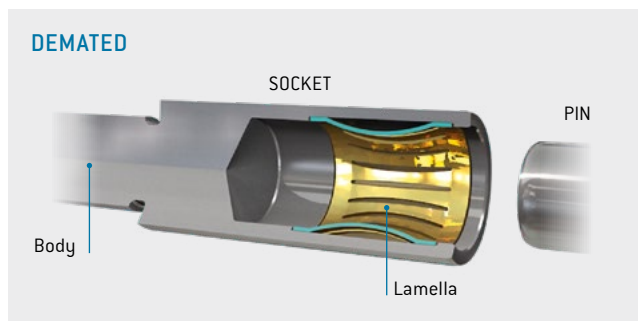

Module 2 contacts	Part number
Insulator	611.161.102.923.000

Description	Part number	Conductor cross-section ¹ mm ²	Nominal current ²		Max. continuous current ³ Single contact A	Contact resistance mΩ
			Single contact A	Module fully equipped A		
Pin contact	181.874.100.200.000	25	105	100	154	0.2
Socket contact	178.874.100.201.000					
Pin contact	181.875.100.200.000	16	90	85	133	0.2
Socket contact	178.875.100.201.000					

¹ Extra fine wire acc. to IEC 60228:2004 (VDE 0295:2005; class 5), class 5. ² Determined acc. to IEC 60512-5-1:2002 (DIN EN 60512-5-1:2003) at a temperature increase of 45 K. ³ Definition max. continuous current see page 189.

MODULE 1 CONTACT



ODU LAMTAC® (Contacts with lamella technology).



Contact diameter: 10 mm or 12 mm
Mating cycles¹: minimum 10,000
Current-carrying capacity²: max. 220 A

TECHNICAL NOTES

- The current load information is valid for single contacts or fully equipped modules. For use in connector systems, the load should be reduced according to VDE 0298-4:2013 [see page 189].
- When automatic docking due to the high mating forces and the high cable cross sections we recommend the assembly in the ODU-MAC P+ [Power] frame [see page 45].
- Crimp information see page 170.

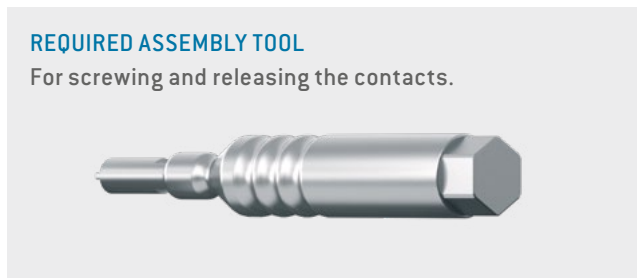

For contact diameter 10 mm.
PART NUMBER: 087.611.003.001.000
 Locking torque: 3.5 Nm ± 0.5 Nm

For contact diameter 12 mm.
PART NUMBER: 087.611.004.001.000
 Locking torque: 3.5 Nm ± 0.5 Nm

For an overview of all tools please see from page 177.

TECHNICAL DATA

Voltage information³

Operating voltage		
Ø 10 mm	250 V	160 V
Ø 12 mm	200 V	63 V
Rated impulse voltage		
Ø 10 mm	4,000 V	4,000 V
Ø 12 mm	3,000 V	3,000 V
Degree of pollution		
Ø 10 mm and Ø 12 mm	2	3

Voltage information acc. to MIL⁴

Operating voltage	
Ø 10 mm	2,000 V
Ø 12 mm	1,500 V
Test voltage	
Ø 10 mm	6,000 V
Ø 12 mm	4,500 V

Mechanical data

Total mating force (average)	
Ø 10 mm	33 N / Module
Ø 12 mm	45 N / Module
Total sliding force (average)	
Ø 10 mm	24 N / Module
Ø 12 mm	30 N / Module
Contact diameter	10 mm or 12 mm
Operating temperature	-40 °C to +125 °C
Mating cycles	minimum 10,000

Materials

Insulator	Thermoplastic fiber glass reinforced acc. to UL-94
Contact body	Cu alloy
Contact lamella	CuBe alloy
Contact finish	Ag

¹ Higher mating cycles by easy exchange of the wear parts (pin/socket from front) possible. The termination area remains unaffected, because of two-part contact.
² Definition max. continuous current see page 189. ³ IEC 60664-1:2007 (VDE 0110-1:2008) see page 183. ⁴ See page 187.



INSULATOR PIN AND SOCKET

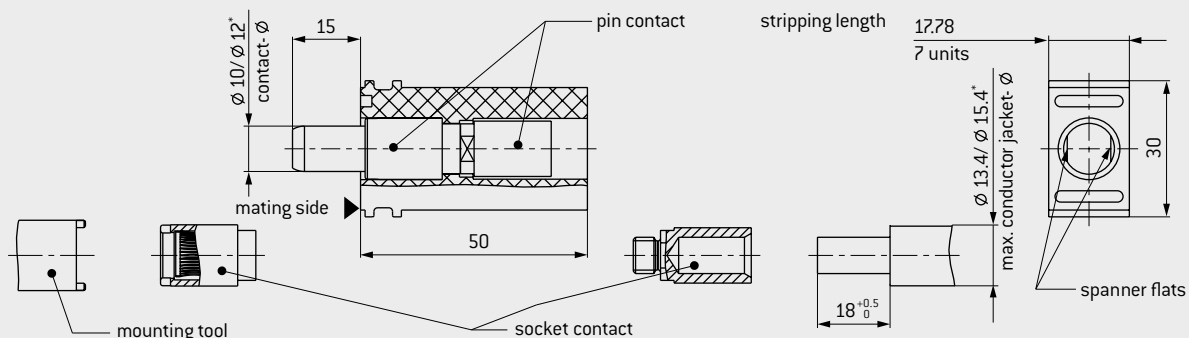

In application with a housing please check the space requirement.

$\varnothing 13.4$: contact- $\varnothing = 10$
 $\varnothing 15.4$: contact- $\varnothing = 12$

ODU LAMTAC® (CONTACTS WITH LAMELLA TECHNOLOGY)

In comparison to the ODU SPRINGTAC contact, ODU LAMTAC offers a lower number of contact surfaces. One or more of the stamped lamellas are mounted in a lathe-turned body (see also page 31).

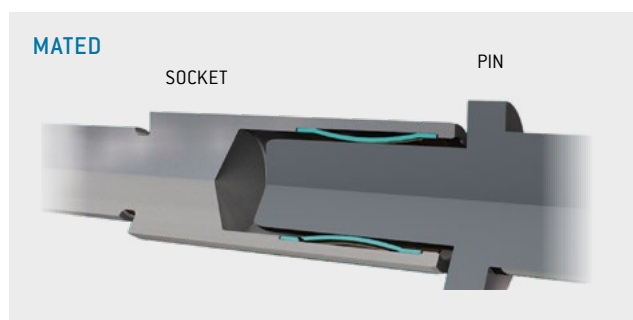
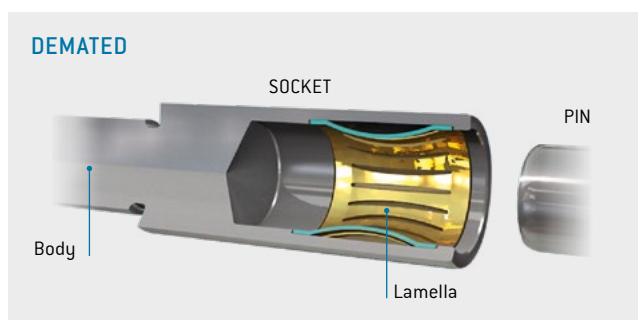

Module 1 contact	Part number
Insulator for contact $\varnothing 10$ mm	611.169.101.923.000
Insulator for contact $\varnothing 12$ mm	611.172.101.923.000

Description	Part number	Conductor cross-section ¹	Nominal current ²	Max. continuous current ³	Contact resistance
		mm ²	Single contact A	Single contact A	m Ω
Pin contact $\varnothing 10$ mm	181.878.100.200.000	35	120	179	0.15
Socket contact $\varnothing 10$ mm	178.878.100.201.000				
Pin contact $\varnothing 10$ mm	181.946.100.200.000	25	110	163	0.15
Socket contact $\varnothing 10$ mm	178.954.100.201.000				
Pin contact $\varnothing 12$ mm	181.943.100.200.000	50	145	220	0.1
Socket contact $\varnothing 12$ mm	178.943.100.201.000				
Pin contact $\varnothing 12$ mm	181.945.100.200.000	35	135	200	0.1
Socket contact $\varnothing 12$ mm	178.953.100.201.000				
Pin contact $\varnothing 12$ mm	181.944.100.200.000	25	115	172	0.1
Socket contact $\varnothing 12$ mm	178.948.100.201.000				

¹ Extra fine wire acc. to IEC 60228:2004 (VDE 0295:2005; class 5), class 5. ² Determined acc. to IEC 60512-5-1:2002 (DIN EN 60512-5-1:2003) at a temperature increase of 45 K. ³ Definition max. continuous current see page 189.

MODULE 4 CONTACTS

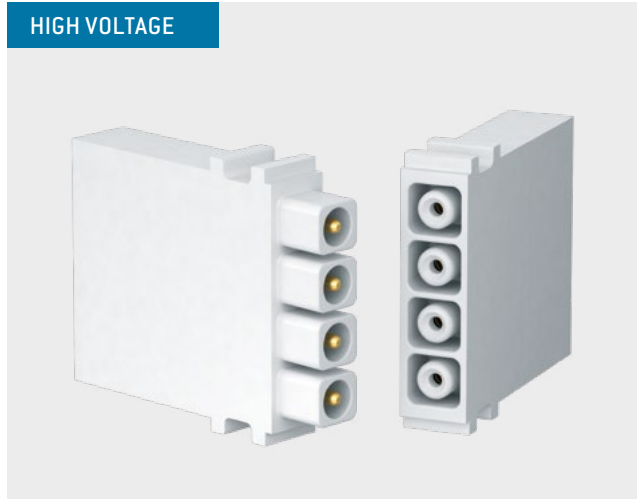
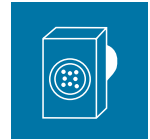

Contact diameter: 1.5 mm
Mating cycles: minimum 100,000
Operating voltage: 2,500 V



Removal of the already assembled contact (incl. cable).
PART NUMBER: 087.170.138.000.000



Removal of unassembled contacts, or contacts from which the cable has been removed.
PART NUMBER: 087.611.001.001.000

For an overview of all tools please see from page [177](#).

TECHNICAL NOTES

- The current load information is valid for single contacts or fully equipped modules. For use in connector systems, the load should be reduced according to VDE 0298-4:2013 (see page [189](#)).
- Crimp information see page [170](#).

TECHNICAL DATA

Voltage information¹

Operating voltage	2,500 V	1,000 V
Rated impulse voltage	10,000 V	8,000 V
Degree of pollution	2	3

Voltage information acc. to MIL²

Operating voltage	2,500 V
Test voltage	7,500 V

Mechanical data

Total mating force (average)	12 N / Module
Total sliding force (average)	9.2 N / Module
Contact diameter	1.5 mm
Operating temperature	-40 °C to +125 °C
Mating cycles	minimum 100,000

Materials

Insulator	Thermoplastic fiber glass reinforced acc. to UL-94
Contact body	Cu alloy
Contact spring	CuSn alloy
Contact finish	
Contact body	Au over Ni
Contact spring	Ag

¹IEC 60664-1:2007 (VDE 0110-1:2008) see page [183](#). ²See page [187](#).



INSULATOR PIN

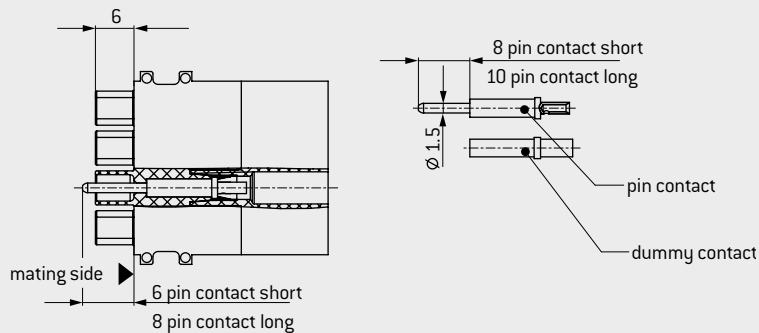

INSULATOR SOCKET

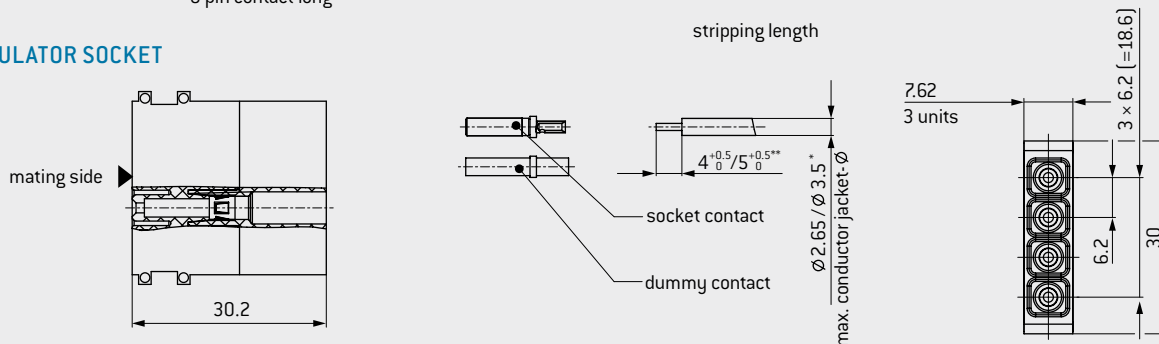

Module 4 contacts	Part number
Insulator socket	610.159.104.923.000
Insulator pin	611.159.104.923.000
Dummy contact	021.341.125.923.000

* ≤ Ø 2.65 removal possible / ≤ Ø 3.5 removal not possible.

** 4^{+0.5}₀: AWG 24–28; 0.25–0.08 mm²

5^{+0.5}₀: AWG 20–22; 0.5–0.38 mm²
AWG 14–18; 0.75–1.5 mm²

Description	Part number	Conductor cross-section mm ²	Termination AWG/mm	Nominal current ²		Max. continuous current ³ Single contact A	Contact resistance mΩ
				Single contact A	Module fully equipped A		
Pin contact short ¹	180.363.000.307.000	1.5	14	18	14.5	27	0.95
Pin contact long ¹	180.383.000.307.000						
Socket contact ¹	170.363.700.201.000						
Pin contact short	180.543.000.307.000	16	16	18	14.5	27	0.95
Pin contact long	180.573.000.307.000						
Socket contact	170.543.700.201.000						
Pin contact short ¹	180.545.000.307.000	1–0.75	18	16	13	22.5	0.95
Pin contact long ¹	180.575.000.307.000						
Socket contact ¹	170.545.700.201.000						
Pin contact short ¹	180.541.000.307.000	0.5–0.38	20–22	10	8	15	0.95
Pin contact long ¹	180.571.000.307.000						
Socket contact ¹	170.541.700.201.000						
Pin contact short	180.857.000.307.000	0.25–0.08	24–28	6	6	9	0.95
Pin contact long	180.856.000.307.000						
Socket contact	170.857.700.201.000						



¹ Non-magnetic version on request. ² Determined acc. to IEC 60512-5-1:2002 (DIN EN 60512-5-1:2003) at a temperature increase of 45 K.

³ Definition max. continuous current see page 189.

MODULE 1 CONTACT

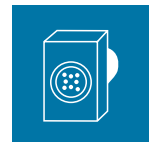

HIGH VOLTAGE

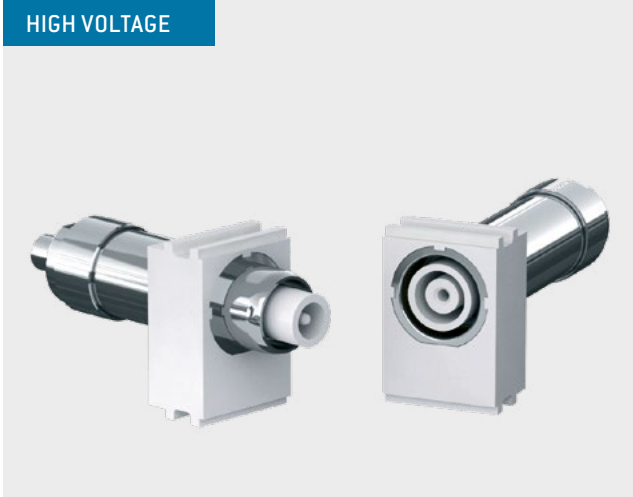

Contact diameter: 2 mm
Mating cycles: minimum 10,000
Operating voltage: 6,300 V

TECHNICAL NOTES

- The current load information is valid for single contacts or fully equipped modules. For use in connector systems, the load should be reduced according to VDE 0298-4:2013 [see page [189](#)].
- Center contact soldered.
- Outer contact crimped.
- Recommended cable construction see page [129](#).

TECHNICAL DATA

Voltage information¹

Operating voltage	6,300 V	2,500 V
Rated impulse voltage	20,000 V	20,000 V
Degree of pollution	2	3
Clearance distance	> 32 mm	
Creepage distance	> 32 mm	

Test of the partial discharge voltage (PDV) acc. to VDE

PDV inception voltage	6.000 V
PDV extinction voltage	5.700 V

Mechanical data

Total mating force (average)	17 N / Module
Total sliding force (average)	15 N / Module
Contact diameter	2 mm
Operating temperature	-40 °C to +125 °C
Mating cycles	minimum 10,000

Materials

Insulator	Thermoplastic fiber glass reinforced acc. to UL-94
Contact body / insulator	Cu alloy / PTFE
Contact spring	CuBe alloy
Contact finish	
Outer contact	gal. Ni
Center contact	gal. Ag

¹IEC 60664-1:2007 (VDE 0110-1:2008) see page [183](#).



INSULATOR FOR PIN AND SOCKET

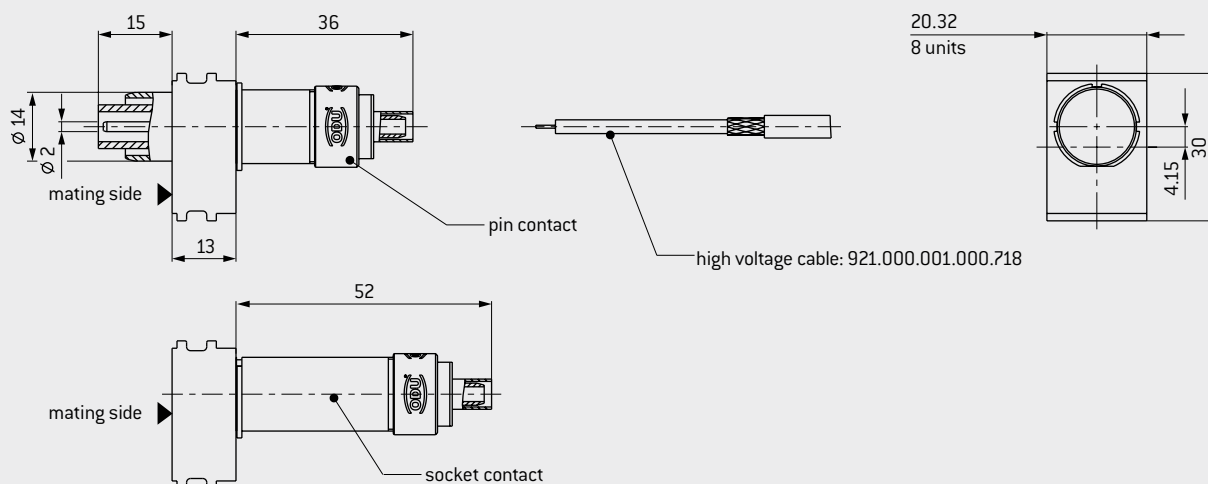

In application with a housing please check the cable space requirement.

CABLE TERMINATION

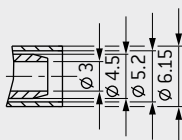

RECOMMENDED CABLE CONSTRUCTION / STRIPPING LENGTH

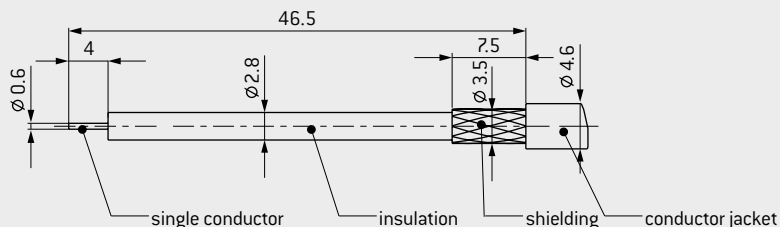

Module 1 contact	Part number
Insulator	611.171.101.923.000

Description	Part number	Part number crimp insert	Conductor cross-section AWG / mm ²	Nominal current A	Contact resistance average mΩ
Pin contact	122.138.001.201.000	082.000.039.106.000	22 / 24	3.5	0.4
Socket contact	122.138.002.201.000				
High voltage line ¹	921.000.001.000.718		0.25		
Crimping tool for shielding sleeve	080.000.039.000.000				

¹Partial discharge test carried out with recommended cable construction.

MODULE 4 CONTACTS FOR 50 Ω



Mating cycles: minimum 60,000

 Non-magnetic

Frequency range¹: 0–1.3 GHz

TECHNICAL NOTES

- Crimp information see page 170.

TECHNICAL DATA

Frequency range¹ 0–1.3 GHz¹
 Insulation resistance > 100 GΩ

Voltage information acc. to MIL²

Operating voltage 350 V
 Test voltage 1,050 V

Mechanical data

Total mating force (average) 17.8 N / Module
 Total sliding force (average) 15.3 N / Module
 Operating temperature –40 °C to +125 °C
 Mating cycles minimum 60,000

Materials

Insulator Thermoplastic fiber glass reinforced acc. to UL-94
 Contact body / insulator Cu alloy / PTFE
 Contact spring CuSn / CuBe alloy
 Contact finish Au over CuSnZn

HIGH FREQUENCY CHARACTERISTICS FOR 50 Ω COAX CONTACTS¹

Insertion loss

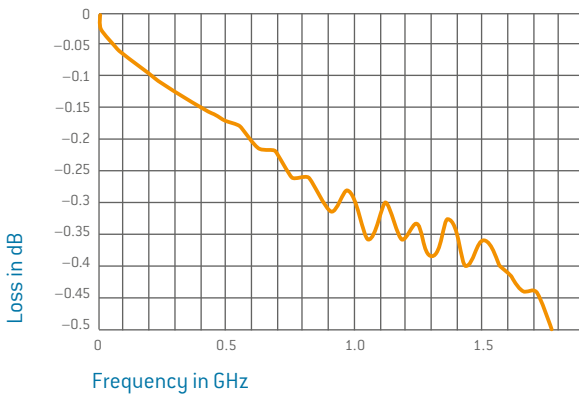

Voltage standing-wave ratio VSWR

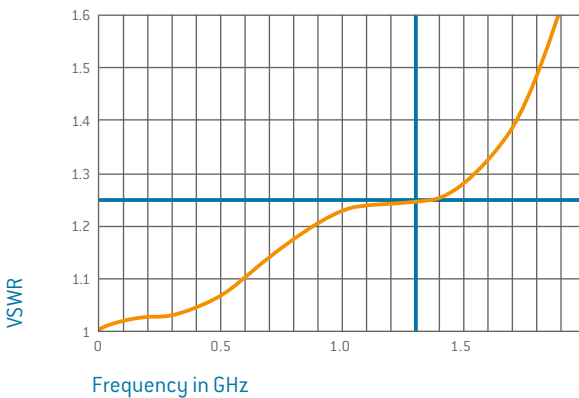

REMOVAL TOOL I (STRAIGHT)



Removal of the already assembled contact (incl. cable).

PART NUMBER: 087.170.139.000.000

REMOVAL TOOL I (ANGLED)



Removal of the already assembled contact (incl. cable).

PART NUMBER: 087.170.365.000.000

REMOVAL TOOL II



Removal of unassembled contacts, or contacts from which the cable has been removed.

PART NUMBER: 087.611.001.001.000

For an overview of all tools please see from page 177.

¹ Loss levels depend on used conductor type at a VSWR of 1.25. Further are available on request. Tested with per 2 × 5 cm conductor length. ² See from page 187.



INSULATOR FOR PIN AND SOCKET

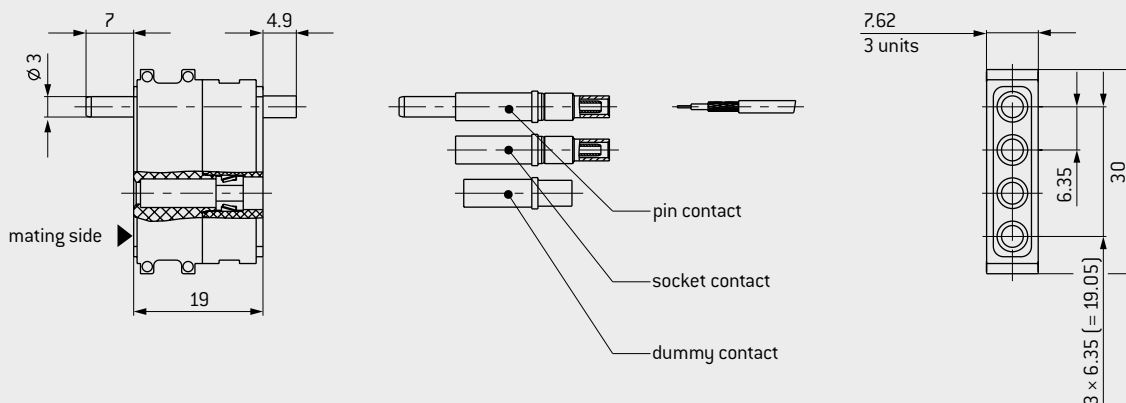

CABLE TERMINATION

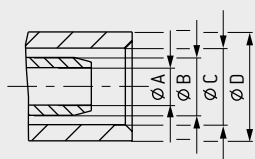

RECOMMENDED CABLE CONSTRUCTION / STRIPPING LENGTH

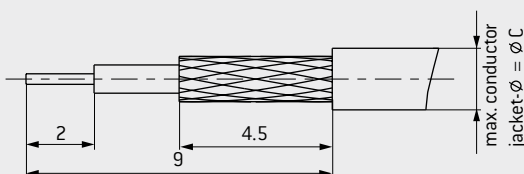

Module 4 contacts	Part number
Insulator	611.149.104.923.000
Dummy contact	021.341.127.923.000

Description	Part number	Characteristic impedance Ω	Frequency range GHz	Cable ¹	A	B	C	D	Part number crimp inserts
Pin contact	122.120.001.257.000	50	1.3	RG 178 / RG 196	1.1	1.7	2.25	3.2	082.000.039.101.000
Pin contact	122.120.003.257.000		0.8	RG 174 / RG 188 / RG 316 (75 Ω: RG 179, RG 187)	1.75	2.7	3.2	3.8	082.000.039.102.000
Pin contact	122.120.011.257.000		0.85	G 02232 (H+S) ²	1.75	2.7	3.5	4.3	082.000.039.103.000
Socket contact	122.120.002.257.000	50	1.3	RG 178 / RG 196	1.1	1.7	2.25	3.2	082.000.039.101.000
Socket contact	122.120.004.257.000		0.8	RG 174 / RG 188 / RG 316 (75 Ω: RG 179, RG 187)	1.75	2.7	3.2	3.8	082.000.039.102.000
Socket contact	122.120.012.257.000		0.85	G 02232 (H+S) ²	1.75	2.7	3.5	4.3	082.000.039.103.000
Crimping tool for shielding sleeve	080.000.039.000.000								

¹Special lines and alternative models on request. ²Removal tool II is not possible due to the conductor diameter.

MODULE 2 CONTACTS FOR 50 Ω WITH SMA TERMINATION



Mating cycles: minimum 100,000
 Frequency range¹: 0–9.0 GHz

TECHNICAL NOTES

Frequency range¹ 0–9.0 GHz
 Insulation resistance > 100 GΩ

Voltage information acc. to MIL²

Operating voltage 350 V
 Test voltage 1,050 V

Mechanical data

Total mating force (average) 11.9 N / Module
 Total sliding force (average) 8.5 N / Module
 Operating temperature –40 °C to +125 °C
 Mating cycles minimum 100,000

Materials

Insulator Thermoplastic fiber glass reinforced acc. to UL-94
 Contact body/insulator Cu alloy / PTFE
 Contact spring CuSn / CuBe alloy
 Contact finish
 Center contact Au over Ni
 Outer contact Ni

HIGH FREQUENCY CHARACTERISTICS FOR 50 Ω COAX CONTACTS¹

Insertion loss

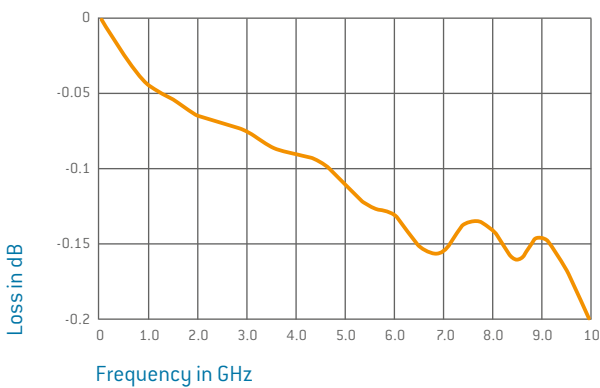

Voltage standing-wave ratio VSWR

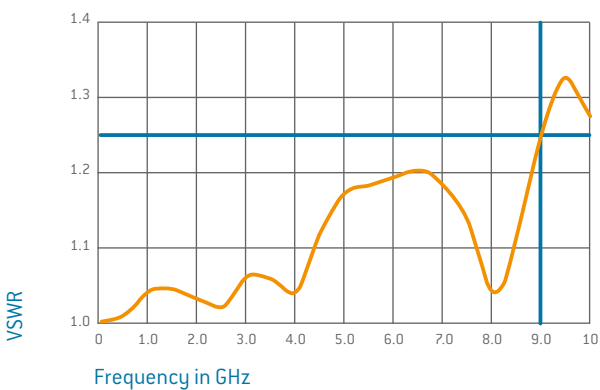

REMOVAL TOOL



PART NUMBER: 087.122.349.000.000

For an overview of all tools please see from page 177.

¹ Loss levels depend on used conductor type at a VSWR of 1.25. Further are available on request. Tested with per 2 × 5 cm conductor length. ² See from page 187.



INSULATOR PIN AND SOCKET

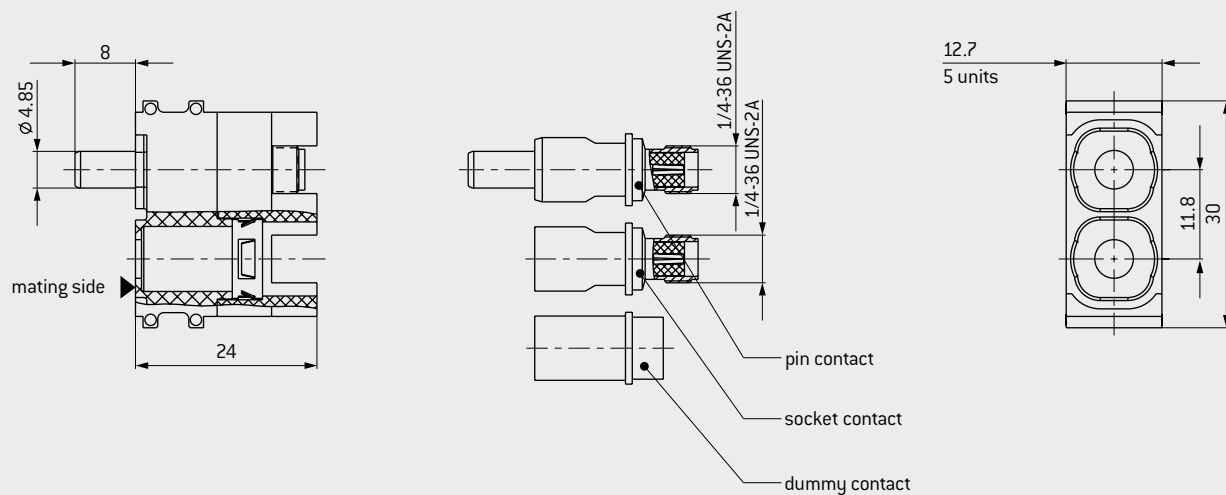

Module 2 contacts	Part number
Insulator	611.152.102.923.000
Dummy contact	021.341.177.300.000

Description	Part number	Characteristic impedance Ω	Frequency range GHz
Pin contact	122.349.001.207.000	50	9.0
Socket contact	122.349.002.207.000		

MODULE 2 CONTACTS FOR 50 Ω

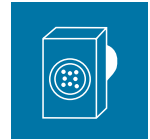

Mating cycles: minimum 100,000
Frequency range¹: 0–2.4 GHz

TECHNICAL NOTES

- Crimp information see page [170](#).

TECHNICAL DATA

Frequency range¹ 0–2.4 GHz
 Insulation resistance > 100 GΩ

Voltage information acc. to MIL²

Operating voltage 400 V
 Test voltage 1,200 V

Mechanical data

Total mating force (average) 11.9 N / Module
 Total sliding force (average) 8.5 N / Module
 Operating temperature –40 °C to +125 °C
 Mating cycles minimum 100,000

Materials

Insulator Thermoplastic fiber glass reinforced acc. to UL-94
 Contact body Cu alloy / PTFE
 Contact spring CuSn- / CuBe alloy
 Contact finish
 Center contact Au over Ni
 Outer contact Ni

HIGH FREQUENCY CHARACTERISTICS FOR 50 Ω COAX CONTACTS¹

Insertion loss

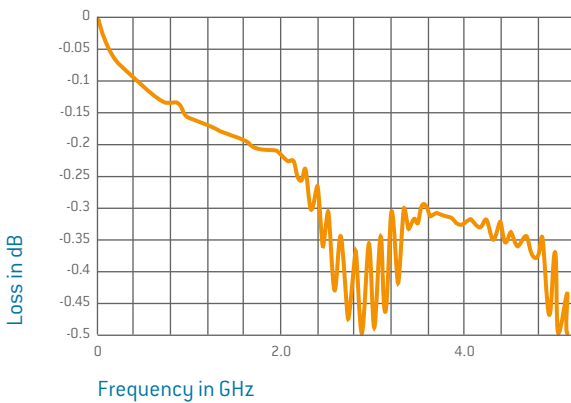

Voltage standing-wave ratio VSWR

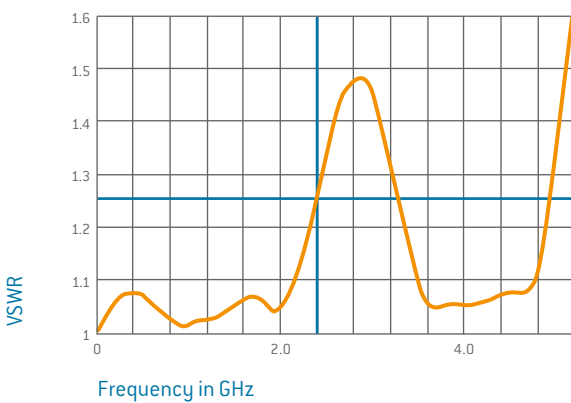

PART NUMBER: 087.170.391.000.000

For an overview of all tools please see from page [177](#).

¹ Loss levels depend on used conductor type at a VSWR of 1.25. Further are available on request. Tested with per 2 × 5 cm conductor length. ² See from page [187](#).



INSULATOR FOR PIN AND SOCKET

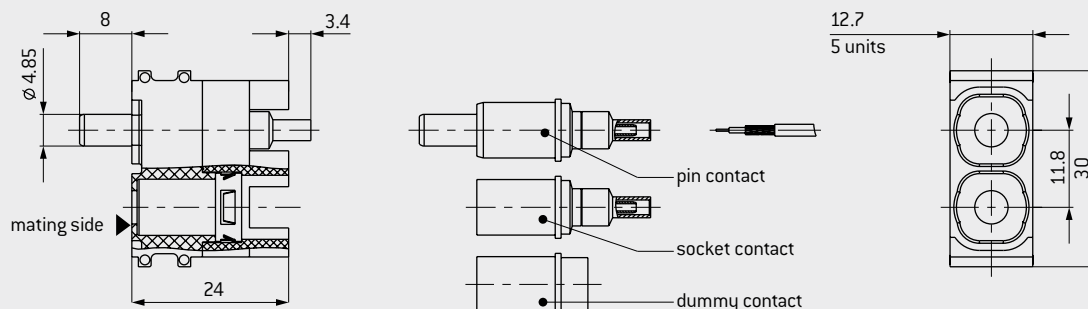

CABLE TERMINATION

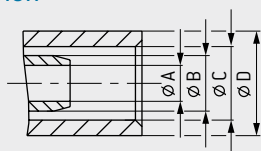

RECOMMENDED CABLE CONSTRUCTION / STRIPPING LENGTH

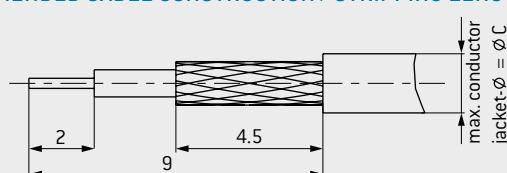

Module 2 contacts	Part number
Insulator	611.152.102.923.000
Dummy contact	021.341.177.300.000

Description	Part number	Characteristic impedance Ω	Frequency range GHz	Cable ¹	A	B	C	D	Part number crimp inserts
Pin contact	122.346.001.207.000	50	1.25	RG 178 / RG 196	1.1	1.7	2.25	3.2	082.000.039.101.000
Pin contact	122.346.003.207.000		2.1	RG 174 / RG 188 / RG 316	1.75	2.7	3.2	3.8	082.000.039.102.000
Pin contact	122.346.005.207.000		RG 122 (2YCY 0,4/2,5-75 Ω)	2.75	3.7	4.2	5	082.000.039.104.000	
Pin contact	122.346.007.207.000		2.4	RG 58	3.15	4.5	5.2	6.15	082.000.039.106.000
Pin contact	122.346.009.207.000		RG 223	3.15	4.5	5.5	6.15	082.000.039.108.000	
Pin contact	122.346.011.207.000		2.1	G 02232 D (H+S) RG 316 D	1.75	2.7	3.5	4.3	082.000.039.103.000
Socket contact	122.346.002.207.000	50	1.25	RG 178 / RG 196	1.1	1.7	2.25	3.2	082.000.039.101.000
Socket contact	122.346.004.207.000		2.1	RG 174 / RG 188 / RG 316	1.75	2.7	3.2	3.8	082.000.039.102.000
Socket contact	122.346.006.207.000		RG 122 (2YCY 0,4/2,5-75 Ω)	2.75	3.7	4.2	5	082.000.039.104.000	
Socket contact	122.346.008.207.000		2.4	RG 58	3.15	4.5	5.2	6.15	082.000.039.106.000
Socket contact	122.346.010.207.000		RG 223	3.15	4.5	5.5	6.15	082.000.039.108.000	
Socket contact	122.346.012.207.000		2.1	G 02232 D (H+S) RG 316 D	1.75	2.7	3.5	4.3	082.000.039.103.000
Crimping tool for shielding sleeve	080.000.039.000.000								

¹Special lines on request.

MODULE 2 CONTACTS FOR 50 Ω AND HIGH VOLTAGE

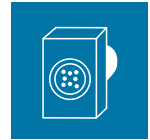

Mating cycles: minimum 100,000

 Non-magnetic

Frequency range¹: 0–2.8 GHz

TECHNICAL NOTES

- Crimp information see page [170](#).

TECHNICAL DATA

Voltage information

Frequency range ¹	0–2.8 GHz
Insulation resistance	> 100 GΩ

Voltage information acc. to MIL²

Operating voltage	850 V
Test voltage	2,600 V

Mechanical data

Total mating force (average)	13.9 N / Module
Total sliding force (average)	9.9 N / Module
Operating temperature	–40 °C to +125 °C
Mating cycles	minimum 100,000

Materials

Insulator	Thermoplastic fiber glass reinforced acc. to UL-94
Contact body	Cu alloy / PTFE
Contact spring	CuSn / CuBe alloy
Contact finish	Au over CuSnZn

HIGH FREQUENCY CHARACTERISTICS FOR 50 Ω COAX CONTACTS¹

Insertion loss

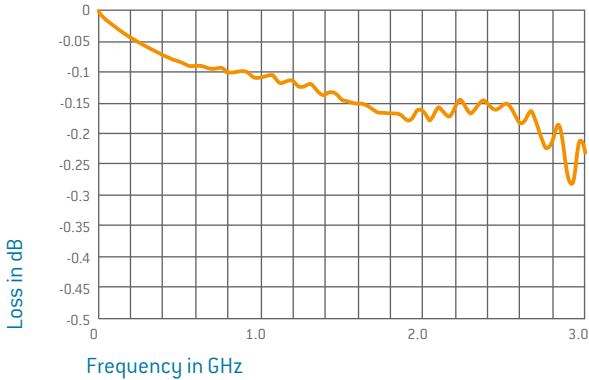

Voltage standing-wave ratio VSWR

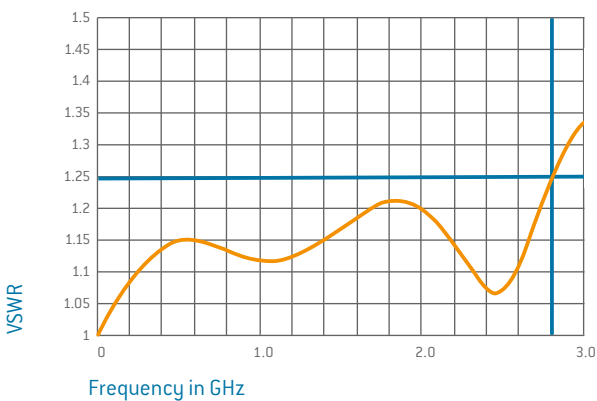

PART NUMBER: 087.170.391.000.000

For an overview of all tools please see from page [177](#).

¹ Loss levels depend on used conductor type at a VSWR of 1.25. Further are available on request. Tested with per 2 × 5 cm conductor length. ² See from page [187](#).



INSULATOR FOR PIN AND SOCKET

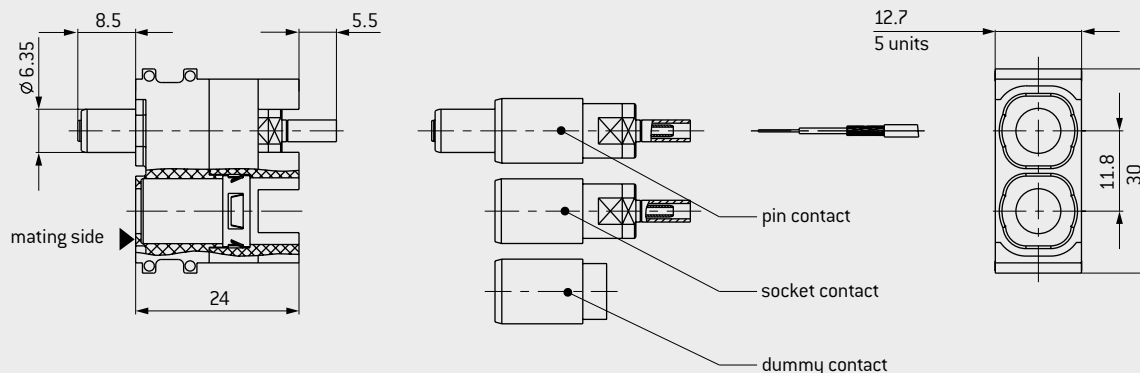

CABLE TERMINATION

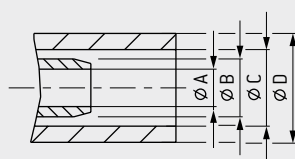

RECOMMENDED CABLE CONSTRUCTION / STRIPPING LENGTH

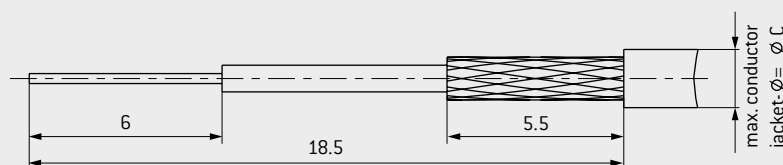

Module 2 contacts	Part number
Insulator	611.155.102.923.000
Dummy contact	021.341.179.923.000

Description	Part number	Characteristic impedance Ω	Frequency range GHz	Cable ¹	A	B	C	D	Part number crimp inserts
Pin contact	122.126.001.257.000	50	0.3	RG 178/RG 196	1.1	1.7	2.25	3.2	082.000.039.101.000
Pin contact	122.126.003.257.000		2.0	RG 174/RG 188/ RG 316	1.75	2.7	3.2	3.8	082.000.039.102.000
Pin contact	122.126.013.257.000		2.8	RG 223	3.15	4.5	5.9	6.75	082.000.039.108.000
Pin contact	122.126.007.257.000		2.6	RG 58	3.15	4.5	5.2	6.15	082.000.039.106.000
Socket contact	122.126.002.257.000	50	0.3	RG 178/RG 196	1.1	1.7	2.25	3.2	082.000.039.101.000
Socket contact	122.126.004.257.000		2.0	RG 174/RG 188/ RG 316	1.75	2.7	3.2	3.8	082.000.039.102.000
Socket contact	122.126.014.257.000		2.8	RG 223	3.15	4.5	5.9	6.75	082.000.039.108.000
Socket contact	122.126.008.257.000		2.6	RG 58	3.15	4.5	5.2	6.15	082.000.039.106.000
Crimping tool for shielding sleeve	080.000.039.000.000								

¹Special lines on request.

MODULE 2 CONTACTS FOR 75 Ω

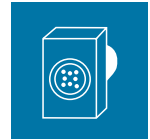

Mating cycles: minimum 100,000
Frequency range¹: 0–3.0 GHz

TECHNICAL NOTES

- Crimp information see page [170](#).

TECHNICAL DATA

Frequency range¹ 0–3.0 GHz
 Insulation resistance > 100 GΩ

Voltage information acc. to MIL²

Operating voltage 475 V
 Test voltage 1,425 V

Mechanical data

Total mating force (average) 13.3 N / Module
 Total sliding force (average) 9.5 N / Module
 Operating temperature –40 °C to +125 °C
 Mating cycles minimum 100,000

Materials

Insulator Thermoplastic fiber glass reinforced acc. to UL-94
 Contact body Cu alloy/PTFE
 Contact spring CuSn / CuBe alloy
 Contact finish
 Center contact Au over Ni
 Outer contact Ni

HIGH FREQUENCY CHARACTERISTICS FOR 75 Ω COAX CONTACTS¹

Insertion loss

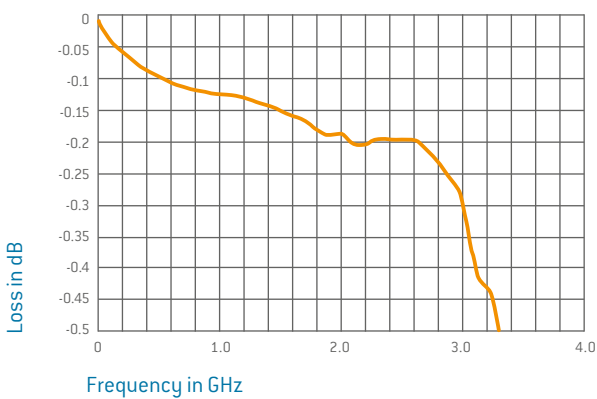

Voltage standing-wave ratio VSWR

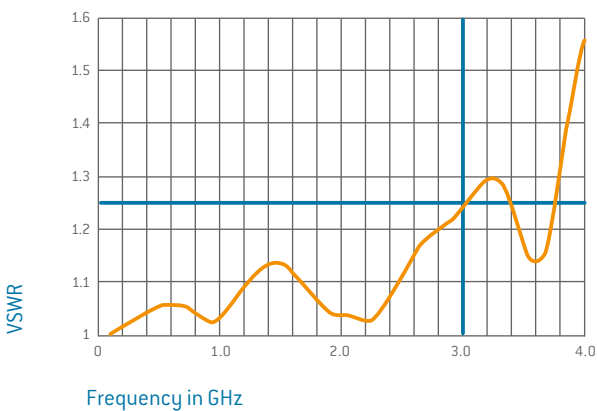

PART NUMBER: 087.170.391.000.000

For an overview of all tools please see from page [177](#).

¹ Loss levels depend on used conductor type at a VSWR of 1.25. Further are available on request. Tested with per 2 × 5 cm conductor length. ² See from page [187](#).



INSULATOR FOR PIN AND SOCKET

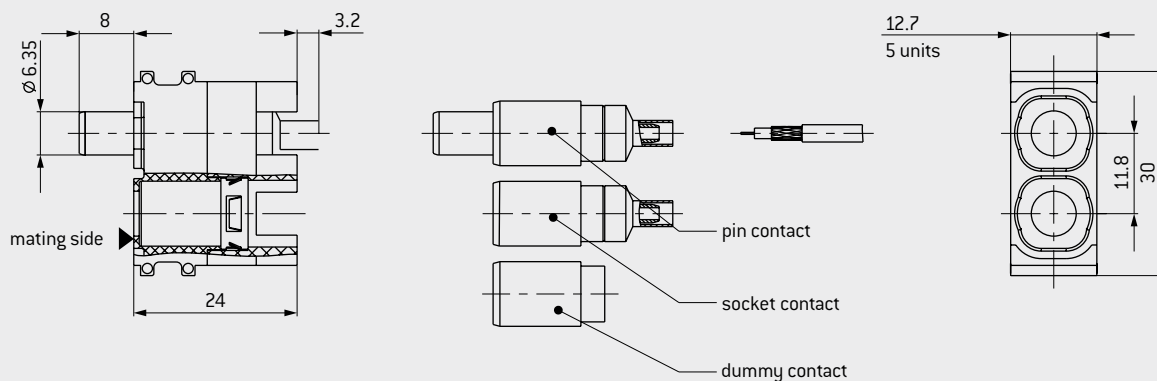

CABLE TERMINATION

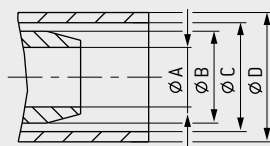

RECOMMENDED CABLE CONSTRUCTION / STRIPPING LENGTH

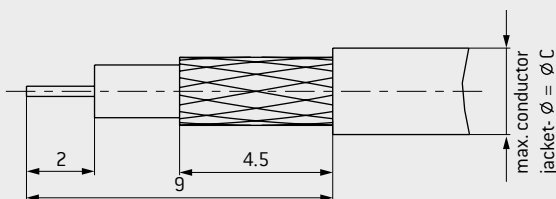

Module 2 contacts	Part number
Insulator	611.155.102.923.000
Dummy contact	021.341.179.923.000

Description	Part number	Characteristic impedance Ω	Frequency range GHz	Cable ¹	A	B	C	D	Part number crimp inserts
Pin contact	122.348.003.207.000	75	3.0	RG 179/RG 187	1.75	2.7	3.2	3.8	082.000.039.102.000
Pin contact	122.348.007.207.000		0.55	G 03233 (H+S)	3.15	4.5	5.2	6.15	082.000.039.106.000
Pin contact	122.348.009.207.000		3.0	RG 59	4	5.4	6.3	7.2	082.000.039.109.000
Socket contact	122.348.004.207.000	75	3.0	RG 179/RG 187	1.75	2.7	3.2	3.8	082.000.039.102.000
Socket contact	122.348.008.207.000		0.55	G 03233 (H+S)	3.15	4.5	5.2	6.15	082.000.039.106.000
Socket contact	122.348.010.207.000		3.0	RG 59	4	5.4	6.3	7.2	082.000.039.109.000
Crimping tool for shielding sleeve	080.000.039.000.000								

¹Special lines on request.

MODULE 2 CONTACTS FOR COMPRESSED AIR VALVES



Inner diameter of tube max. 4 mm, Push-in diameter max. 6 mm.

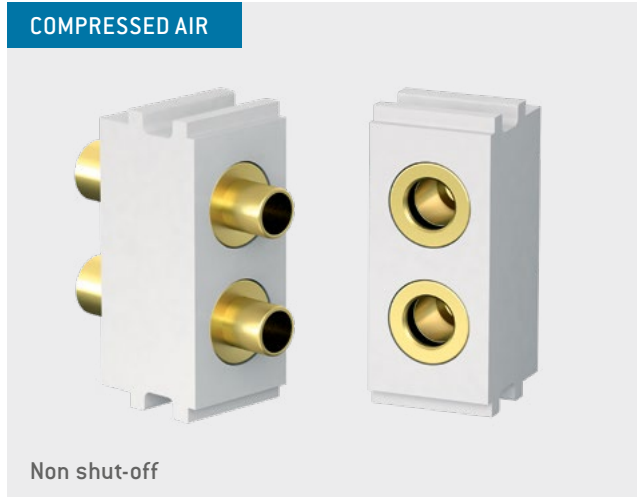

Operating pressure: 20 bar
 Mating cycles¹: minimum 100,000
 Inner diameter tube: M5 or max. 4 mm

TECHNICAL NOTES

- The contacts are pre-stressed in the mated state. The frame must maintain this pre-stress with a holding device.
- Vacuum model and further termination types on request.
- No O₂ model².

TECHNICAL DATA

Mechanical data

Valid max. operating pressure	20 bar
Total mating force (average)	
non shut-off	27 N / Module
one side shut-off	28 N / Module
both side shut-off	29 N / Module
Total sliding force (average)	
non shut-off	12.6 N / Module
one side shut-off	12.6 N / Module
both side shut-off	9.2 N / Module
Operating temperature	-40 °C to +125 °C
Mating cycles ¹	minimum 100,000
Tube termination	M5 internal thread for commercially available Push-in connections

Materials

Insulator	Thermoplastic fiber glass reinforced acc. to UL-94
Valve body	Cu alloy, blank
Sealing	NBR / FKM

FLOW RATE DIAGRAM

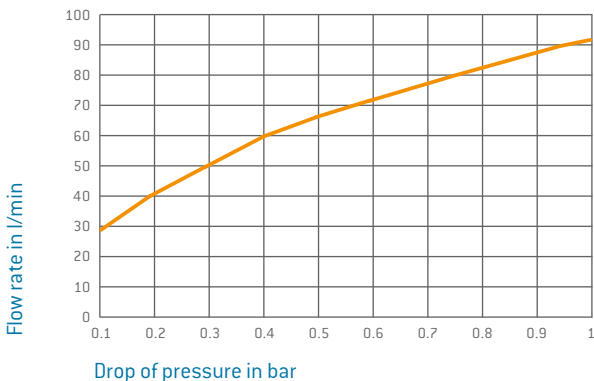

The flow rate diagram refers to the locking version with a maximum gap between socket and pin piece of ≤ 0.5 mm. If the clearance is modified, the drop of pressure increases.

¹ Specified mating cycles through regular service intervals possible. ² Not suitable for mixtures containing more than 25% oxygen content and explosive gases.



INSULATOR PIN AND SOCKET

ACCESSORIES SEE PAGE 148

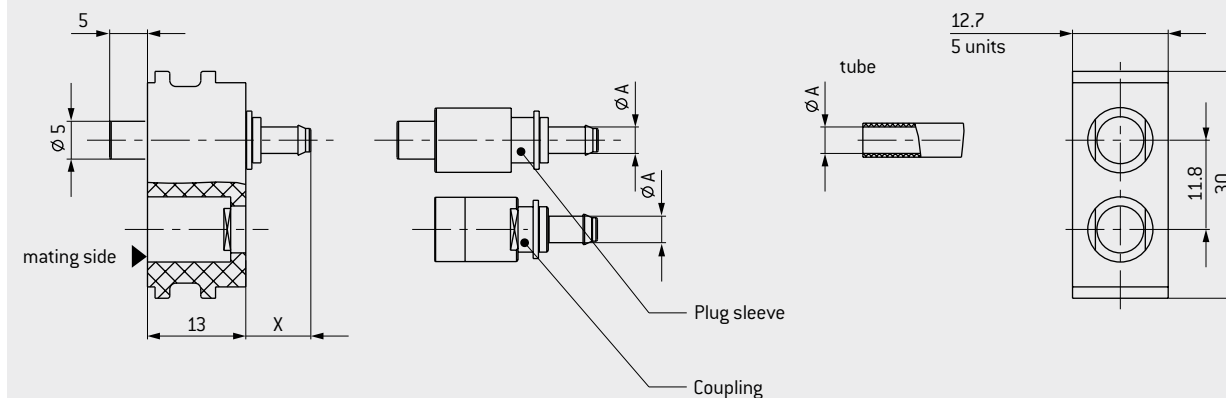

Module 2 contacts	Part number
Insulator	611.141.102.923.000

Description	Part number	Dim. A	Dim. X	Termination types see page 148	
				I	II
Plug sleeve (non shut-off)	196.023.001.300.000	3	8.5	x	
Plug sleeve (non shut-off)	196.024.001.300.000	4	10.5	x	
Plug sleeve (non shut-off)	196.025.001.300.000	M5	–		x
Coupling plug (non shut-off)	196.023.003.300.000	3	8.5	x	
Coupling plug (non shut-off)	196.024.003.300.000	4	10.5	x	
Coupling plug (non shut-off)	196.025.003.300.000	M5	–		x
Plug sleeve (shut-off) ^{1,2}	196.025.014.300.000	M5	–		x
Coupling plug (shut-off)	196.023.002.300.000	3	8.5	x	
Coupling plug (shut-off)	196.024.002.300.000	4	10.5	x	
Coupling plug (shut-off) ²	196.025.012.300.000	M5	–		x

¹Only pluggable on coupling plug 196.025.012.300.000. ²Material sealing: FKM.

MODULE 2 CONTACTS FOR COMPRESSED AIR VALVES

Inner diameter of tube max. 6 mm.

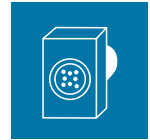

Operating pressure: 12 bar
Mating cycles¹: minimum 100,000
Inner diameter tube: max. 6 mm

TECHNICAL NOTES

- The contacts are pre-stressed in the mated state. The frame must maintain this pre-stress with a holding device.
- Vacuum model and further termination types on request.
- No O₂ model².

TECHNICAL DATA

Mechanical data

Valid max. operating pressure	12 bar
Total mating force (average)	
non shut-off	10.8 N / Module
one side shut-off	12.8 N / Module
Total sliding force (average)	
non shut-off	6.8 N / Module
one side shut-off	6.8 N / Module
Operating temperature	-40 °C to +125 °C
Mating cycles ¹	minimum 100,000

Materials

Insulator	Thermoplastic fiber glass reinforced acc. to UL-94
Valve body	Cu alloy, blank
Sealing	NBR

FLOW RATE DIAGRAM

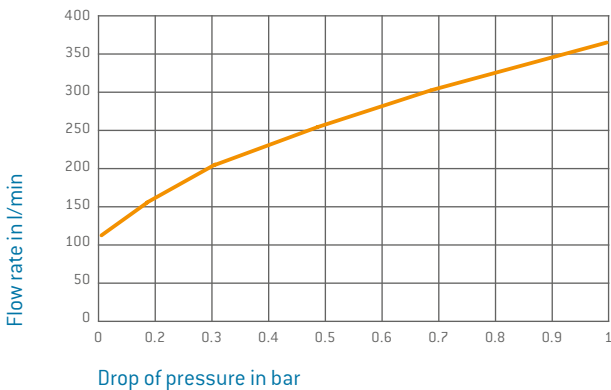

The flow diagram refers to the blocking variant with a maximum gap between socket and pin piece of ≤ 0.5 mm. The pressure reduction increases in the event of a changed gap measurement.

¹ Specified mating cycles through regular service intervals possible. ² Not suitable for mixtures containing more than 25% oxygen content and explosive gases.



INSULATOR PIN AND SOCKET

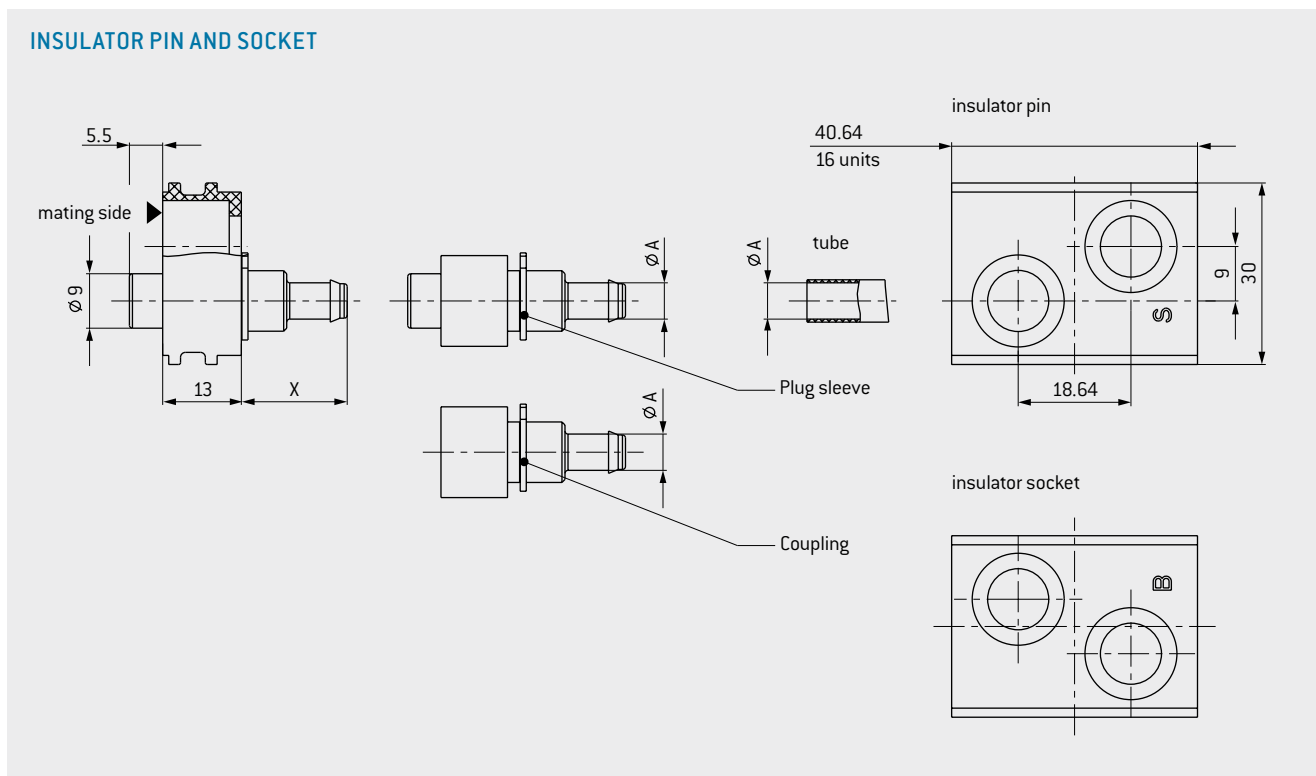

Module 2 contacts	Part number
Insulator socket	610.140.102.923.000
Insulator pin	611.140.102.923.000

Description	Part number	Dim. A mm	Dim. X mm
Plug sleeve (non shut-off)	196.001.001.300.000	4	15
Plug sleeve (non shut-off)	196.002.001.300.000	6	17.5
Coupling plug (non shut-off)	196.001.003.300.000	4	15
Coupling plug (non shut-off)	196.002.003.300.000	6	17.5
Coupling plug (shut-off)	196.001.002.300.000	4	15
Coupling plug (shut-off)	196.002.002.300.000	6	17.5

MODULE 1 CONTACT FOR COMPRESSED AIR VALVES



Inner diameter of tube max. 6 mm.



Operating pressure: 12 bar
Mating cycles¹: minimum 100,000
Inner diameter tube: max. 6 mm

TECHNICAL NOTES

- The contacts are pre-stressed in the mated state. The frame must maintain this pre-stress with a holding device.
- Vacuum model and further termination types on request.
- No O₂ model².

TECHNICAL DATA

Mechanical data

Valid max. operating pressure	12 bar
Total mating force (average)	
non shut-off	5.4 N / Module
one side shut-off	6.4 N / Module
Total sliding force (average)	
non shut-off	3.4 N / Module
one side shut-off	3.4 N / Module
Operating temperature	-40 °C to +125 °C
Mating cycles ¹	minimum 100,000

Materials

Insulator	Thermoplastic fiber glass reinforced acc. to UL-94
Valve body	Cu alloy, blank
Sealing	NBR

FLOW RATE DIAGRAM

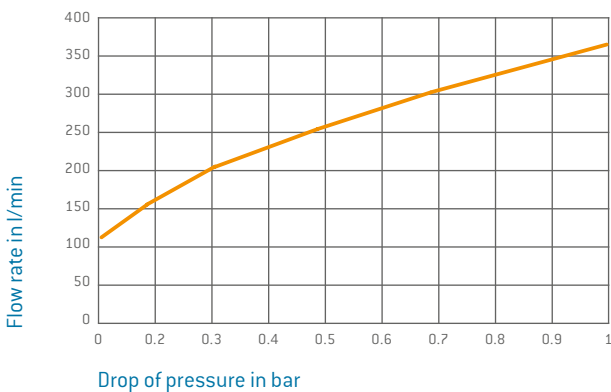

The flow diagram refers to the blocking variant with a maximum gap between socket and pin piece of ≤ 0.5 mm. The pressure reduction increases in the event of a changed gap measurement.

¹ Specified mating cycles through regular service intervals possible. ² Not suitable for mixtures containing more than 25% oxygen content and explosive gases.



INSULATOR PIN AND SOCKET

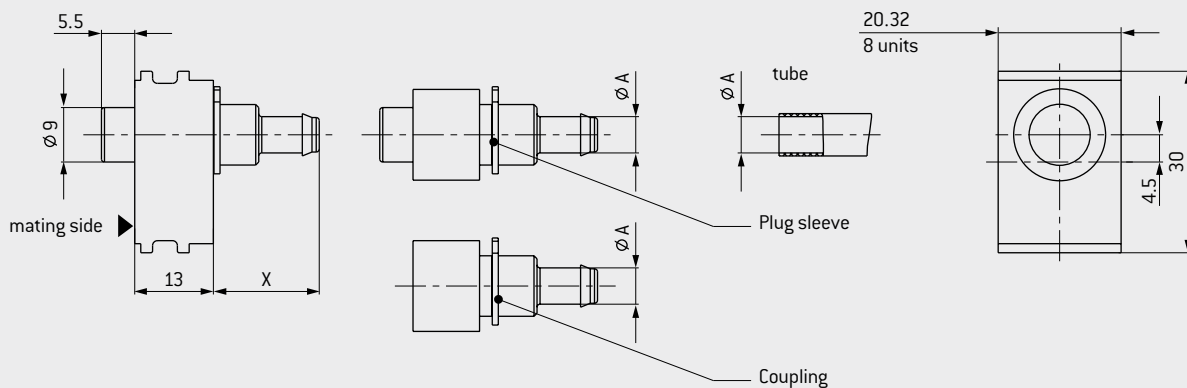

Module 1 contact	Part number
Insulator	611.142.101.923.000

Description	Part number	Dim. A mm	Dim. X mm
Plug sleeve (non shut-off)	196.001.001.300.000	4	15
Plug sleeve (non shut-off)	196.002.001.300.000	6	17.5
Coupling plug (non shut-off)	196.001.003.300.000	4	15
Coupling plug (non shut-off)	196.002.003.300.000	6	17.5
Coupling plug (shut-off)	196.001.002.300.000	4	15
Coupling plug (shut-off)	196.002.002.300.000	6	17.5

MODULE 2 CONTACTS

Suitable for conducting air, water and other fluids.

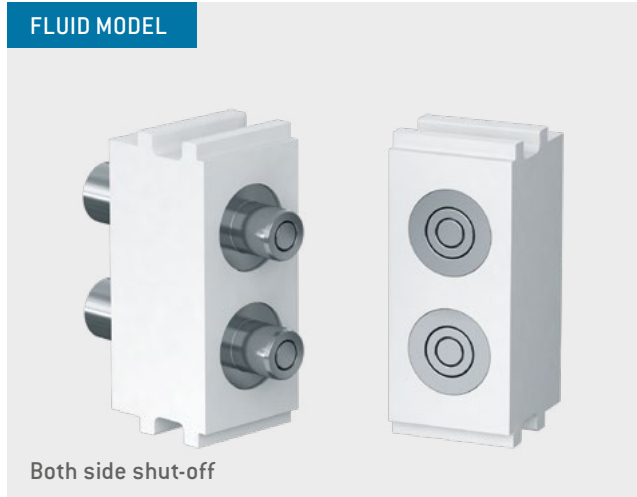
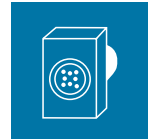

Operating pressure: 10 bar low-leakage model
Mating cycles¹: minimum 100,000
Inner diameter tube: M5

TECHNICAL NOTES

- The contacts are pre-stressed in the mated state. The frame must maintain this pre-stress with a holding device.
- The use of flammable or explosive liquids or gases is not allowed.
- No O₂ model².

TECHNICAL DATA

Mechanical data

Valid max. operating pressure	10 bar
Tube termination	M5 internal thread for commercially available Push-in connections
Total mating force (average)	64 N / Module
Total sliding force (average)	0 N / Module
Operating temperature	-40 °C to +125 °C
Mating cycles ¹	minimum 100,000

Materials

Insulator	Thermoplastic fiber glass reinforced acc. to UL-94
Fluid model	Stainless steel (1.4305)
Sealing	NBR

FLOW RATE DIAGRAM AIR

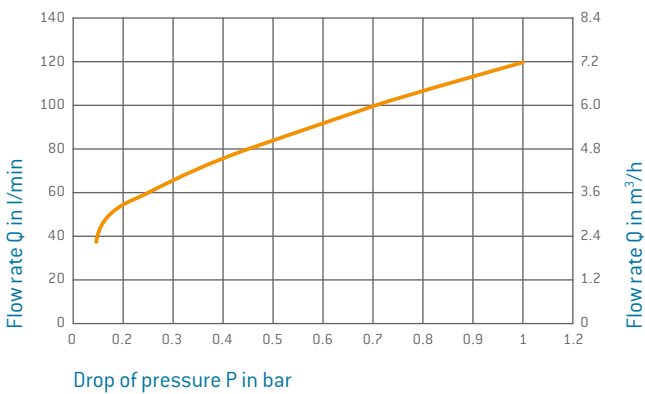

FLOW RATE DIAGRAM WATER

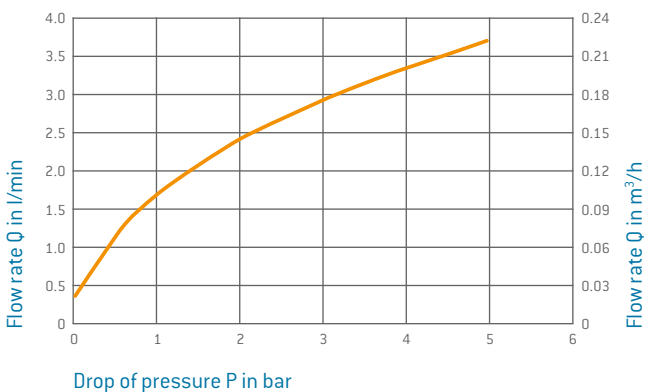

The flow diagram refers to the blocking variant with a maximum gap between socket and pin piece of ≤ 0.5 mm. The pressure reduction increases in the event of a changed gap measurement.

¹ Specified mating cycles through regular service intervals possible. ² Not suitable for mixtures containing more than 25% oxygen content and explosive gases.



INSULATOR PIN AND SOCKET

ACCESSORIES SEE PAGE 148

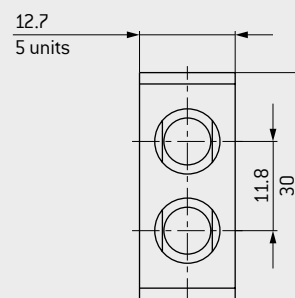
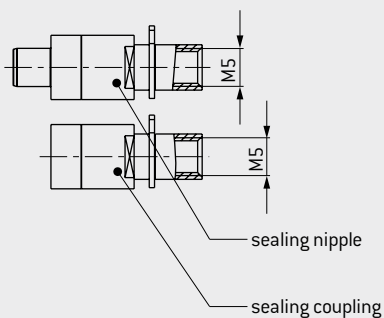
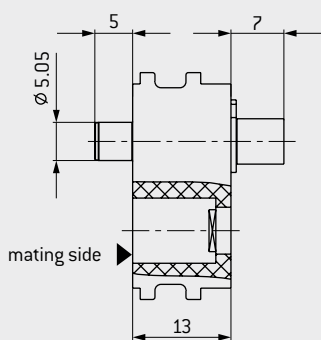

Module 2 contacts	Part number
Insulator	611.141.102.923.000

Description	Part number	Termination mm
Plug sleeve (pin piece)	196.025.015.902.001	M5
Coupling plug (socket piece)	196.025.016.902.001	M5

ACCESSORIES

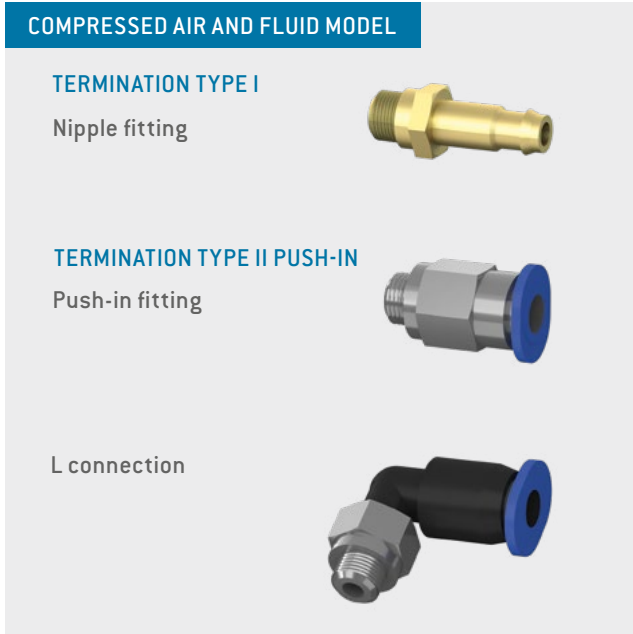

TECHNICAL NOTES

- Tightening torque 1.5 Nm

TECHNICAL DATA

Mechanical data

Valid operating pressure (static)	0.95 to 14 bar
Operating temperature	-10 °C to +80 °C
Thread termination	M5

Description	Part number	Dim. A	Dim. B	Dim. C	Dim. D	Dim. E	Dim. F
		Inner diameter of tube mm	Outer diameter of tube mm	incl. sealing washer			mm
Nipple fitting	945.000.001.000.123	2		10.2			
Nipple fitting	945.000.001.000.136	3		14.2			
Nipple fitting	945.000.001.000.137	4		15.8			
Push-in fitting	945.000.001.000.138		3		13		
Push-in fitting	945.000.001.000.139		4		13.2		
Push-in fitting	945.000.001.000.140		6		14.2		
L connection Push-in	945.000.001.000.141		3			14	11
L connection Push-in	945.000.001.000.142		4			14.9	15.6
L connection Push-in	945.000.001.000.143		6			17.2	16.2



TERMINATION DIMENSIONS, FOR ACCESSORIES USED WITH FLUID COUPLING AND RETAINER RING.

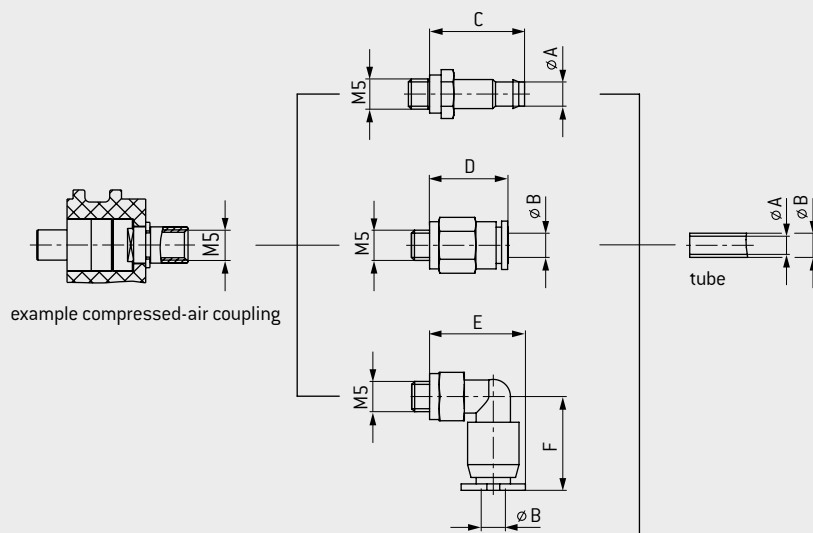

ASSEMBLY OF THE MODEL (DEPENDING ON MODEL)

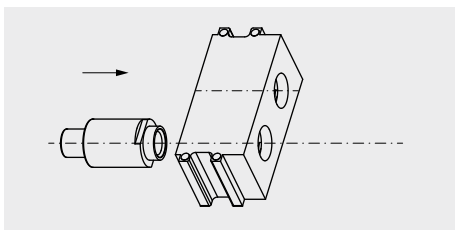

1. Insert model in insulator.

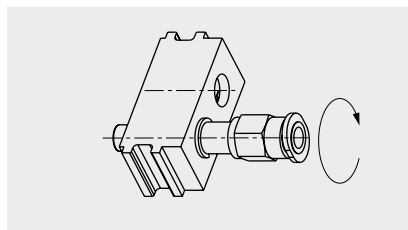

2. Screw termination accessories in model.
Tightening torque 1.5 Nm.

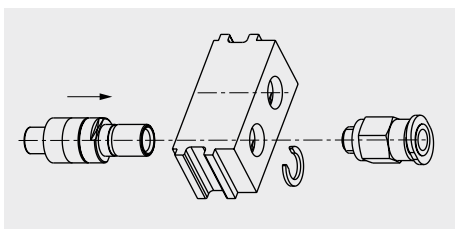

1. Insert model in insulator
and assemble retaining ring.

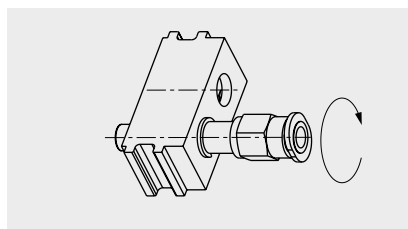

2. Screw termination accessories in model.
Tightening torque 1.5 Nm.

MODULE 5 CONTACTS FOR PLASTIC FIBER POF

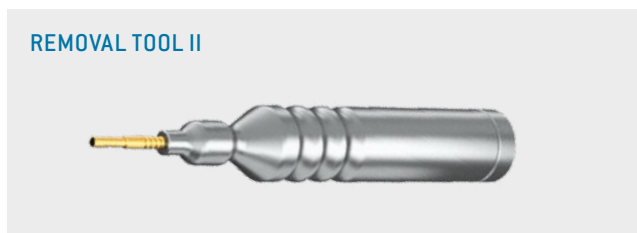
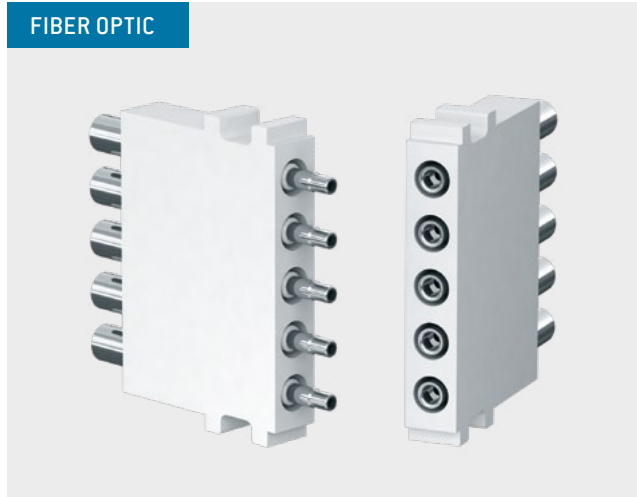
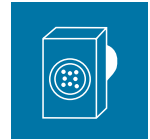

Removal from front, cutting-off not necessary.

PART NUMBER: 087.611.001.002.000

For an overview of all tools please see from page [177](#).

Ferrule

Mating cycles: minimum 40,000

Non-magnetic on request

TECHNICAL NOTES

- Conditional with the function, the contacts are pre-stressed in the mated state. This pre-stressing must be maintained by the frame via a holding device.

TECHNICAL DATA

Mechanical data

POF (Polymer Optical Fiber)	1 mm
Outer diameter	2.2 mm–2.3 mm
Fiber fastening	Crimp
Insertion loss	
Typical	1.5 dB at 670 nm
During life-time	< 2 dB at 670 nm
Total mating force (average)	< 17.5 N
Operating temperature (depending on fiber)	
Standard fiber	–40 °C to +85 °C
High temperature fiber	–40 °C to +115 °C
Mating cycles	minimum 40,000

Materials

Insulator	Thermoplastic fiber glass reinforced acc. to UL-94
Fiber optic contact	Cu alloy
Type of fiber	Plastic fiber 980/1.000 (POF)



INSULATOR PIN AND SOCKET

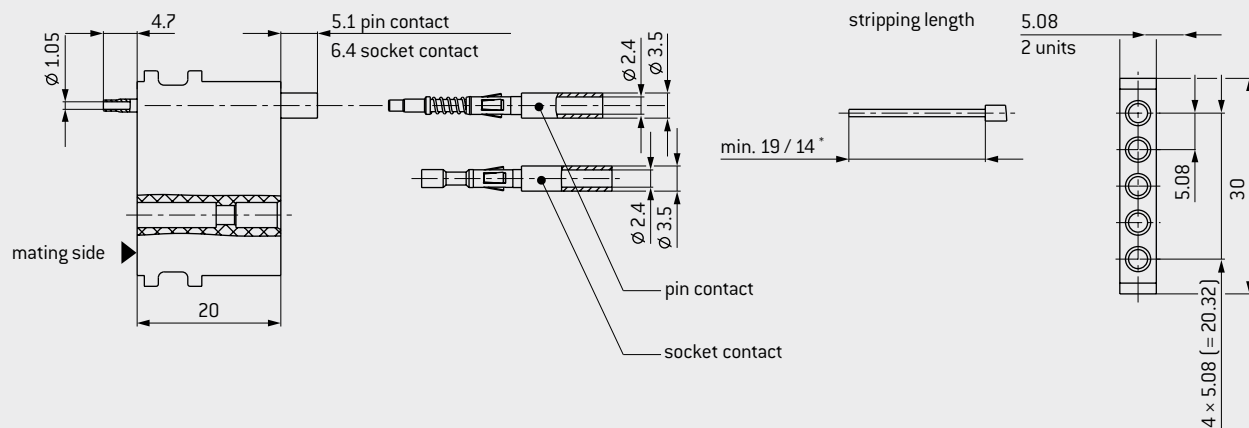

* min. 19 pin contact / min. 14 socket contact

Module 5 contacts	Part number
Insulator	611.163.105.923.000

Description	Part number
Socket contact 980 / 1,000 µm	196.503.001.901.000
Pin contact 980 / 1,000 µm	196.503.002.901.000
Processing set (multi-purpose and crimping tool)	080.000.048.000.000
Cutting/stripping universal pliers	080.000.048.100.000
Crimping tool	080.000.048.200.000

For assembly instructions please refer to our website: www.odu-connectors.com/downloads.

MODULE 2 CONTACTS FOR PLASTIC FIBER POF / MOST

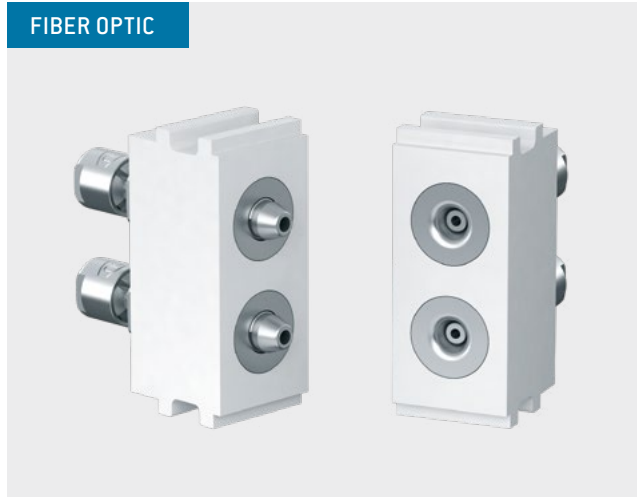
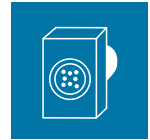

FIBER OPTIC

Ferrule
Mating cycles: minimum 100,000
Type of plastic fiber: POF / MOST

TECHNICAL NOTES

- The contacts are pre-stressed in the mated state. The frame must maintain this pre-stress with a holding device.
- Lens connector on request.

TECHNICAL DATA

Mechanical data

POF (Polymer Optical Fiber)	1 mm
Outer diameter	2.2 mm–2.3 mm
Fiber fastening	Clamping
Insertion loss	
Typical	1.5 dB at 670 nm
During life-time	< 2 dB at 670 nm
Total mating force (average)	16 N
Operating temperature (depending on fiber)	
Standard fiber	–40 °C to +85 °C
High temperature fiber	–40 °C to +115 °C
Mating cycles	minimum 100,000

Materials

Insulator	Thermoplastic fiber glass reinforced acc. to UL-94
Fiber optic contact	Cu alloy
Type of fiber	Plastic fiber 980/1.000 (POF) or 980/1.550 (MOST)



INSULATOR PIN AND SOCKET

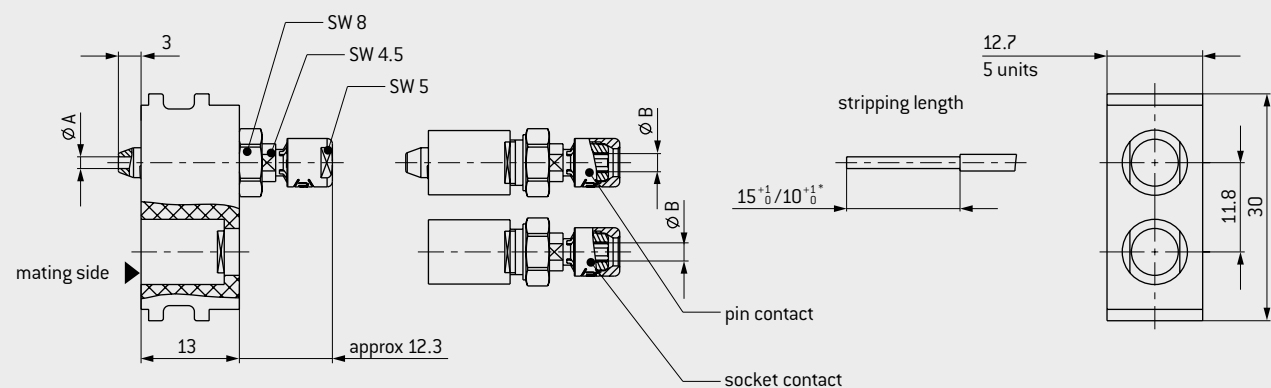

* 15^{+1}_0 pin contact / 10^{+1}_0 socket contact

Module 2 contacts	Part number
Insulator	611.141.102.923.000

Description	Part number	Dim. A mm	Dim. B mm
Socket contact 980 / 1,000 μ m	196.501.001.901.000	1.05	2.25
Pin contact 980 / 1,000 μ m	196.501.002.901.000	1.05	2.25
Socket contact 980 / 1,550 μ m (MOST standard)	196.502.001.901.000	1.6	2.35
Pin contact 980 / 1,550 μ m (MOST standard)	196.502.002.901.000	1.6	2.35
Cable-stripping tool	598.501.001.000.000		
Spanner wrench 4.5 mm	598.501.002.000.000		
Spanner wrench 5 mm	598.700.001.016.000		
Nutdriver 8 mm	598.501.003.000.000		
Polish-device for socket	598.501.004.000.000		
Spare blades	598.501.006.000.000		
Polish-device for pin	598.501.007.000.000		
Lapp foils, 12 μ m, 5 μ m	598.501.010.000.000		

For assembly instructions please refer to our website: www.odu-connectors.com/downloads.

MODULE 3 CONTACTS FOR FIBER GLASS GOF

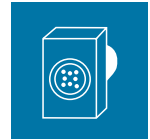

Ceramic Ferrule
Single-mode / multi-mode
Mating cycles¹: minimum 100,000

TECHNICAL NOTES

- The contacts are pre-stressed in the mated state. The frame must maintain this pre-stress with a holding device.
- Lens connector on request.

TECHNICAL DATA

Mechanical data

Fiber glass	Single-mode – 9/125 µm Multi-mode – 50/125 µm
Fiber fastening	Multi-mode – 62.5/125 µm Fiber optic glued ² Surface polished ² Sheath crimped
Insertion loss typical	< 1 dB for 670 nm
Total mating force (average)	≤ 36 N
Assembly holding force	10 N to 12 N / contact
Operating temperature	–40 °C to +85 °C
Mating cycles ¹	minimum 100,000

Materials

Insulator	Thermoplastic fiber glass reinforced acc. to UL-94
Ferrule holder	Nickel silver
Ferrule	Ceramic
Spring	CrNi steel



Removal of the already assembled contact (incl. cable).
PART NUMBER: 087.170.136.000.000



Removal of unassembled contacts, or contacts from which the cable has been removed.
PART NUMBER: 087.611.001.001.000

For an overview of all tools please see page [177](#).

¹ Specified mating cycles through regular service intervals possible. ² Fiber assembly (glue and polish) on request.



INSULATOR PIN

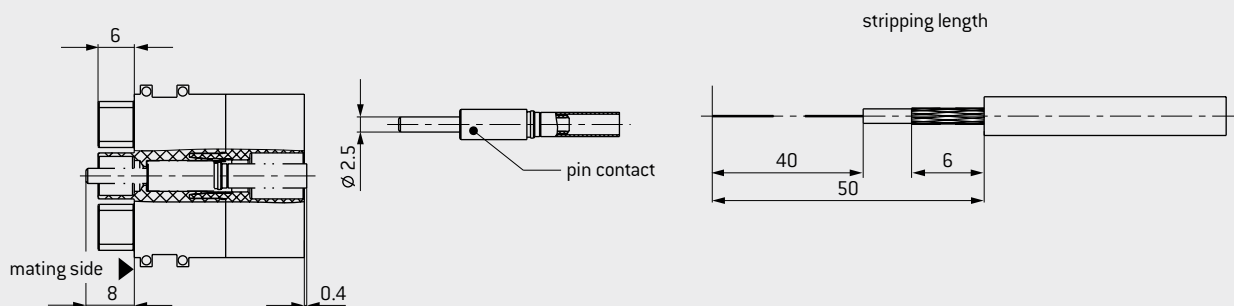

INSULATOR SOCKET

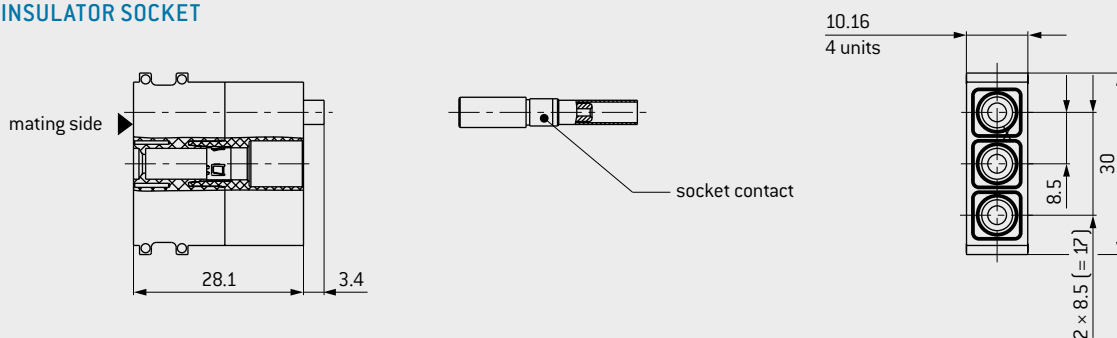

Module 3 contacts	Part number
Insulator pin piece	611.162.103.923.000
Insulator socket piece	610.162.103.923.000

Description	Part number	Part number crimp insert	Optical fiber
Pin contact	196.603.002.901.000	082.000.039.102.000	50 / 125 μm; 62.5 / 125 μm
Pin contact	196.603.004.901.000		9 / 125 μm
Socket contact	196.603.001.901.000		50 / 125 μm; 62.5 / 125 μm
Socket contact	196.603.003.901.000		9 / 125 μm
Crimping tool for shielding sleeve	080.000.039.000.000		

For assembly instructions please refer to our website: www.odu-connectors.com/downloads.

MODULE FOR MULTI-POSITION, SHIELDED IMPLEMENTATION/HIGH-SPEED CONNECTOR



Size 0 (e. g. insert in bus systems).



Mating cycles: minimum 10,000
 USB® 2.0¹, USB® 3.1 Gen1¹, CAT 5¹
 2 to 10 contacts

TECHNICAL NOTES

- The inserts listed here for shielded implementations / high-speed connectors are optimally suitable for all common bus systems with transfer rates up to 10 MHz. For example, Profibus®¹, USB® 1.1¹, RS485, FlexRay®¹, CAN-Bus¹ and RS232.
- Selected inserts are suitable and qualified for data rates up to 5 GBits/s. For example, Fast-Ethernet¹, USB® 2.0¹, USB® 3.1 Gen1¹, FireWire® S400¹ (on request), IEEE 1394.

HOW TO CONFIGURE YOUR HIGH-SPEED CONNECTOR

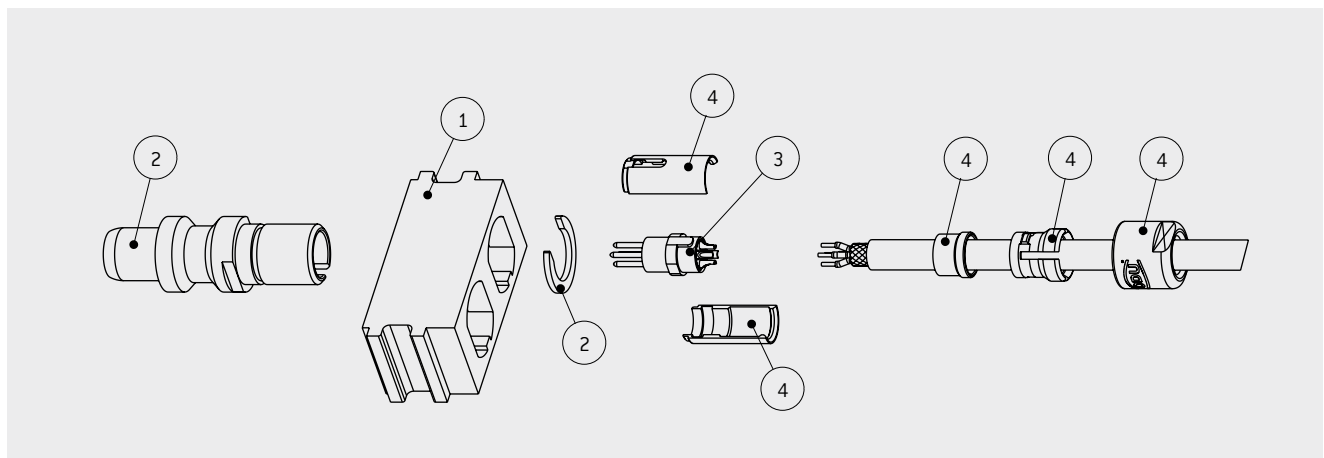

ASSEMBLY SET

Order	Base parts	Part number
1	Insulator	611.148.102.923.000
2	Socket housing complete	653.001.001.304.000
2	Connector housing complete	653.001.002.304.000
	Dummy contact	021.341.182.300.000
3	Insert complete solder contacts ²	see next page
4	Assembly set	see table on the right

Cable Ø mm	Part number
1.5 to 2	653.001.001.304.020
2 to 2.5	653.001.001.304.025
2.5 to 3	653.001.001.304.030
3 to 3.5	653.001.001.304.035
3.5 to 4	653.001.001.304.040
4 to 4.5	653.001.001.304.045
4.5 to 5	653.001.001.304.050
5 to 6.1	653.001.001.304.061 ³

¹ Concerning data transmission protocols please note page 2. ² Available with crimp contact upon request. ³ It's possible that the cable collet cannot be covered completely over the cable.



INSULATOR PIN

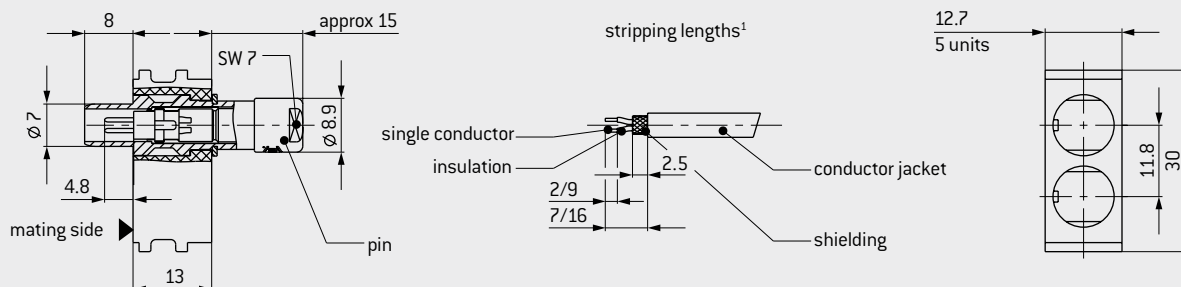

INSULATOR SOCKET

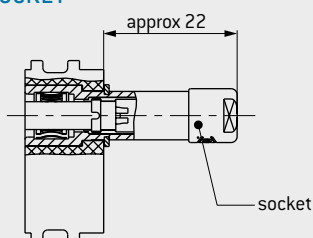

In application with a housing please check the space requirement.

CONTACT ARRANGEMENTS

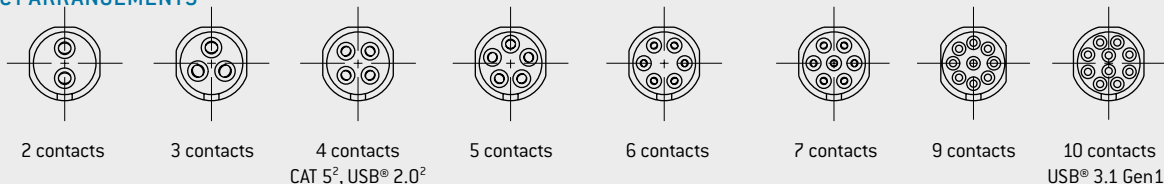

Number of contacts	Contact diameter mm	Termination cross-section AWG	Rated voltage ³ V	Rated impulse voltage ³ kV	Degree of pollution ³	Nominal voltage ⁴ V AC	Model	Category ⁵	Insert complete ⁶ Part number	Total mating force N	Total sliding force N
--------------------	---------------------	-------------------------------	------------------------------	---------------------------------------	----------------------------------	-----------------------------------	-------	-----------------------	--	----------------------	-----------------------

INSERT WITH ODU TURNTAC® (MATING CYCLES MINIMUM 10,000)

2	0.9	22	10	2	3	500	Pin		700.849.724.002.200	20	15
			32	2	2		Socket	700.749.724.002.200			
3	0.9	22	32	1.5	2	400	Pin		700.849.724.003.200	20	15
							Socket		700.749.724.003.200		
4	0.7	26	32	1.5	2	300	Pin	CAT 5 ²	700.848.724.004.200	22	17
							Socket		700.748.724.004.200		
4	0.7	22	32	1.5	2	300	Pin	USB® 2.0 ²	700.848.724.404.221	22	17
							Socket		700.748.724.404.200		
5	0.7	26	32	1.5	2	366	Pin		700.848.724.005.200	22	17
							Socket		700.748.724.005.200		
6	0.5	28	32	1.5	2	300	Pin		700.841.724.006.200	22	17
							Socket		700.741.724.006.200		
7	0.5	28	32	1.5	2	300	Pin		700.841.724.007.200	22	17
							Socket		700.741.724.007.200		
9	0.5	28	10	1.2	2	200	Pin		700.841.724.009.200	23.5	18
							Socket		700.741.724.009.200		
10	0.5	28	10	1.2	2	200	Pin		700.841.724.010.221	23.5	18
							Socket		700.741.724.010.221		
10	6 × 0.3 4 × 0.5	28 24	10	1.2	2	100	Pin	USB® 3.1 Gen1 ²	700.831.724.410.000	16	12
							Socket		700.731.724.410.000		

¹You will find the required lengths in the relevant assembly instructions. ²Concerning data transmission protocols please note page 2. ³Acc. to IEC 60664-1:2007 (VDE 0110-1:2008), see page 183. ⁴Acc. to EIA-364-20D:2008, SAE AS 13441:2004 method 3001.1. ⁵Classification acc. to ISO/IEC 11801:2017. ⁶Several inserts in crimp model on request.

MODULE FOR MULTI-POSITION, SHIELDED IMPLEMENTATION/HIGH-SPEED CONNECTOR



Size 1 (e. g. insert in bus systems).



Mating cycles: minimum 10,000 / 60,000
USB® 2.0¹, CAT 5¹
2 to 14 contacts

TECHNICAL NOTES

- The inserts listed here for shielded implementations/high-speed connectors are optimally suitable for all common bus systems with transfer rates up to 10 MHz. For example, Profibus®¹, RS485, FlexRay®¹, CAN-Bus¹ and RS232.
- Selected inserts are suitable and qualified for data rates up to 1 Gbit/s. For example, Gigabit-Ethernet¹, Fast-Ethernet¹, IEEE 1394, USB® 2.0¹, FireWire® S400¹ [on request].

HOW TO CONFIGURE YOUR HIGH-SPEED CONNECTOR

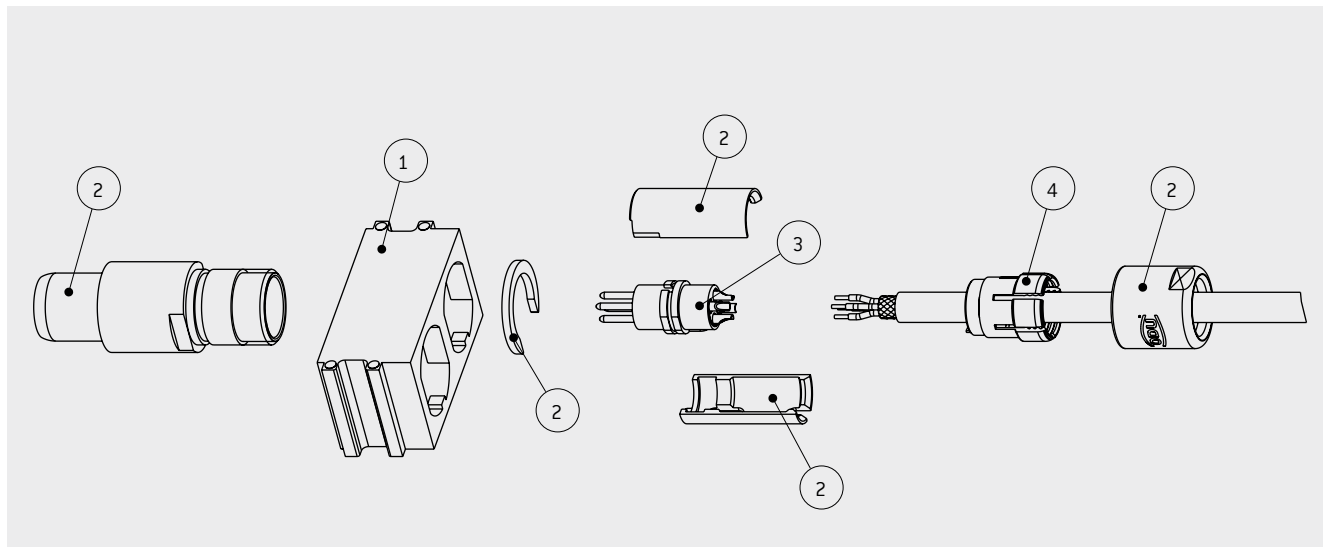

ASSEMBLY SET

Order	Base parts	Part number
1	Insulator	611.167.102.923.000
2	Socket housing complete	653.002.001.304.000
2	Connector housing complete	653.002.002.304.000
	Dummy contact	021.341.186.300.000
3	Insert complete solder contacts ²	see next page
4	Assembly set	see table on the right

Cable Ø mm	Part number
1.5 to 2.1	751.020.188.304.022
2 to 3.2	751.020.188.304.032
3 to 4.2	751.020.188.304.042
4 to 5.2	751.020.188.304.052
5 to 6.2	751.020.188.304.062
6 to 7.2	751.020.188.304.072
7 to 7.7	751.020.188.304.077 ³

¹ Concerning data transmission protocols please note page 2. ² Available with crimp contact upon request. ³ It's possible that the cable collet cannot be covered completely over the cable.



INSULATOR PIN

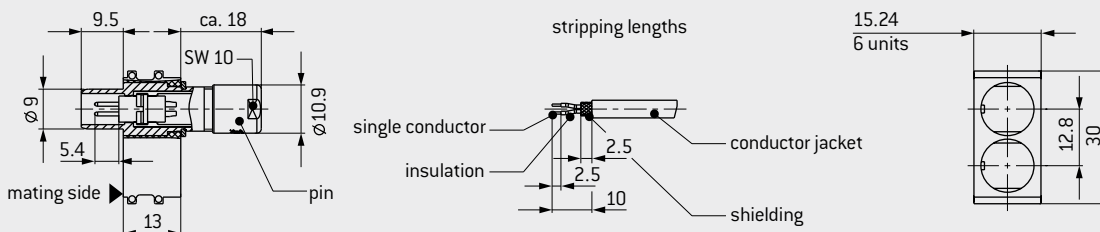

INSULATOR SOCKET

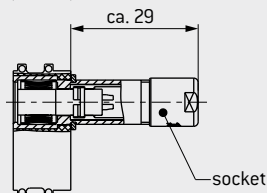

In application with a housing please check the space requirement.

CONTACT ARRANGEMENTS

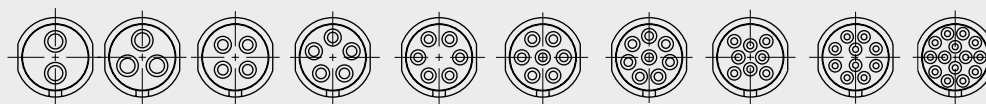

2 contacts 3 contacts 4 contacts 5 contacts 6 contacts 7 contacts 8 contacts 8 contacts 10 contacts 14 contacts
CAT 5⁵, USB[®] 2.0⁵ CAT 5⁵

Number of contacts	Contact diameter mm	Termination cross-section AWG	Rated voltage ¹ V	Rated impulse voltage ¹ kV	Degree of pollution ¹	Nominal voltage ² V AC	Model	Category ³	Insert complete ⁴ Part number	Total mating force N	Total sliding force N
--------------------	---------------------	-------------------------------	------------------------------	---------------------------------------	----------------------------------	-----------------------------------	-------	-----------------------	--	----------------------	-----------------------

INSERT WITH ODU TURNTAC[®] (MATING CYCLES MINIMUM 10,000)

2	1.3	20	32	2	3	550	Pin	CAT 5 ⁵	701.844.724.002.200	8.5	7.5
			80				Socket		701.744.724.002.200		
3	1.3	20	16	2	3	500	Pin	CAT 5 ⁵	701.844.724.003.200	8.5	7.5
			40				Socket		701.744.724.003.200		
4	0.9	22	10	2	3	500	Pin	CAT 5 ⁵	701.849.724.004.200	10.5	9
			32				Socket		701.749.724.004.200		
4	0.9	22	10	2	3	500	Pin	USB [®] 2.0 ⁵	701.849.724.004.D00	10.5	9
			32				Socket		701.749.724.004.D00		
5	0.9	22	32	1.5	2	450	Pin	CAT 5 ⁵	701.849.724.005.200	10.5	9
			32				Socket		701.749.724.005.200		
6	0.7	22	32	1.5	2	400	Pin	CAT 5 ⁵	701.848.724.406.200	13	10
			32				Socket		701.748.724.406.200		
7	0.7	22	32	1.5	2	400	Pin	CAT 5 ⁵	701.848.724.407.200	13	10
			32				Socket		701.748.724.407.200		
8	0.7	22	32	1.5	2	333	Pin	CAT 5 ⁵	701.848.724.408.200	13	10
			32				Socket		701.748.724.408.200		
8	0.5	26	32	1.5	2	333	Pin	CAT 5 ⁵	701.841.724.408.D00	13	10.5
			32				Socket		701.741.724.408.D00		
10	0.5	28	25	1.5	2	333	Pin	CAT 5 ⁵	701.841.724.010.400	15	12
			25				Socket		701.741.724.010.200		
14	0.5	28	25	1.5	2	300	Pin	CAT 5 ⁵	701.841.724.014.400	15	12
			25				Socket		701.741.724.014.200		

INSERT WITH ODU SPRINGTAC[®] (MATING CYCLES MINIMUM 60,000)

4	0.76	22	25	2	3	450	Pin	CAT 5 ⁵	701.842.724.004.700	7.5	7
			63				Socket		701.742.724.004.700		
5	0.76	22	25	1.5	3	400	Pin	CAT 5 ⁵	701.842.724.005.700	8.5	8
			63				Socket		701.742.724.005.700		

¹ Acc. to IEC 60664-1:2007 [VDE 0110-1:2008], see page 183. ² Acc. to EIA-364-20D:2008, SAE AS 13441:2004 method 3001.1.

³ Classification acc. to ISO/IEC 11801:2017. ⁴ Several inserts in crimp model on request. ⁵ Concerning data transmission protocols please note page 2.

MODULE FOR MULTI-POSITION, SHIELDED IMPLEMENTATION/HIGH-SPEED CONNECTOR



Size 2 (e. g. insert in bus systems).



Mating cycles: minimum 10,000 / 60,000
 CAT 5¹, CAT 6_A¹, HDMI^{®1}
 4, 8 and 16 contacts

TECHNICAL NOTES

- The inserts listed here for shielded implementations / high-speed connectors are optimally suitable for all common bus systems with transfer rates up to 10 MHz. For example, Profibus^{®1}, RS485, FlexRay^{®1}, CAN-Bus¹ and RS232.
- Selected inserts are suitable and qualified for data rates up to 10 GBit/s. E. g. 10 Gigabit-Ethernet¹, Gigabit-Ethernet¹, Fast-Ethernet¹, IEEE 1394, HDMI^{®1}.

HOW TO CONFIGURE YOUR HIGH-SPEED CONNECTOR

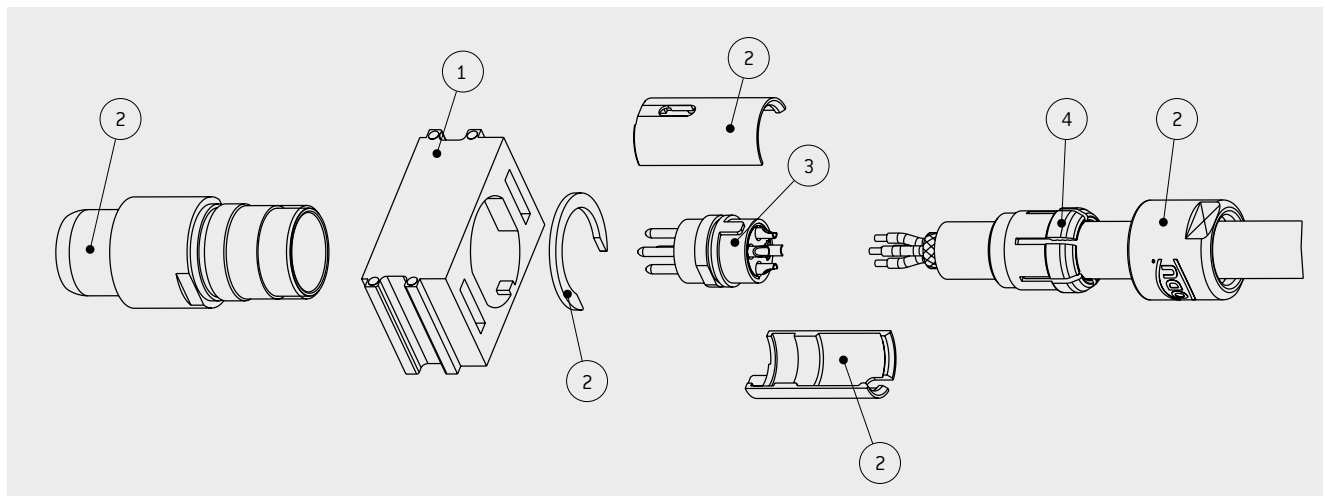

ASSEMBLY SET

Order	Base parts	Part number
1	Insulator	611.170.101.923.000
2	Socket housing complete	653.003.001.304.000
2	Connector housing complete	653.003.002.304.000
3	Insert complete solder contacts ²	see next page
4	Assembly set	see table on the right

Cable Ø mm	Part number
2 to 3.2	752.020.188.304.032
3 to 4.2	752.020.188.304.042
4 to 5.2	752.020.188.304.052
5 to 6.2	752.020.188.304.062
6 to 7.2	752.020.188.304.072
7 to 8.2	752.020.188.304.082
8 to 9.2	752.020.188.304.092
9 to 9.9	752.020.188.304.099

¹Concerning data transmission protocols please note page 2. ²Available with crimp contact upon request.



INSULATOR PIN

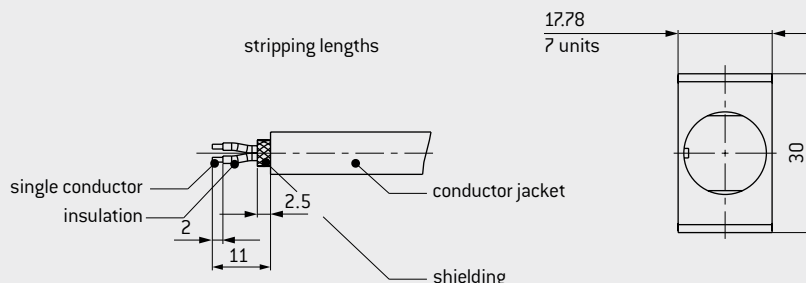
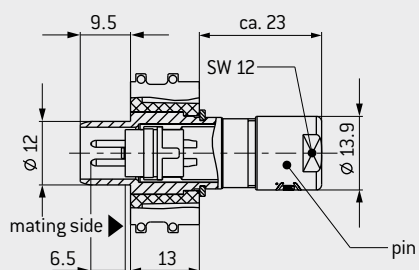

INSULATOR SOCKET

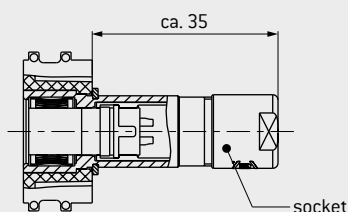

In application with a housing please check the space requirement.

CONTACT ARRANGEMENTS

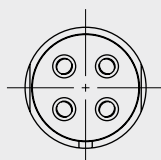

4 contacts
CAT 5⁵

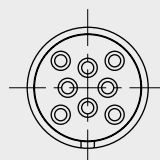

8 contacts
CAT 5⁵
CAT 6_A⁵

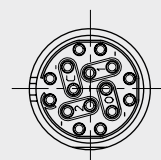

16 contacts
HDMI^{®5}

Number of contacts	Contact diameter mm	Termination cross-section AWG	Rated voltage ¹ V	Rated impulse voltage ¹ kV	Degree of pollution ¹	Nominal voltage ² V AC	Model	Categor ³	Insert complete ⁴ Part number	Total mating force N	Total sliding force N
--------------------	---------------------	-------------------------------	------------------------------	---------------------------------------	----------------------------------	-----------------------------------	-------	----------------------	--	----------------------	-----------------------

INSERT WITH ODU TURNTAC[®] (MATING CYCLES MINIMUM 10,000)

4	1.3	20	40	2.5	3	650	Pin	CAT 5 ⁵	702.844.724.004.200	8.5	8
			160		2		Socket		702.744.724.004.200		
8	0.9	22	20	2	3	500	Pin	CAT 6 _A ⁵	702.849.724.008.D00	14.7	12.6
			50		2		Socket		702.749.724.008.D00		
16	0.5	26	10	1.5	3	250	Pin	HDMI ^{®5}	702.841.724.416.D00	30	23
			32		2		Socket		702.741.724.416.D00		

INSERT WITH ODU SPRINGTAC[®] (MATING CYCLES MINIMUM 60,000)

8	0.76	22	16	2	3	550	Pin	CAT 5 ⁵	702.842.724.008.D00	11.5	10.5
			40		2		Socket		702.742.724.008.D00		

¹Acc. to IEC 60664-1:2007 [VDE 0110-1:2008], see page 183. ²Acc. to EIA-364-20D:2008, SAE AS 13441:2004 method 3001.1.

³Classification acc. to ISO/IEC 11801:2017. ⁴Several inserts in crimp model on request. ⁵Concerning data transmission protocols please note page 2.

MODULE FOR MULTI-POSITION, SHIELDED IMPLEMENTATION/HIGH-SPEED CONNECTOR



Size 3 (e. g. for use in bus systems).



Mating cycles: minimum 10,000
10 to 30 contacts

TECHNICAL NOTES

- The inserts listed here for shielded implementations / high-speed connectors are optimally suitable for all common bus systems with transfer rates to 10 MHz. For example, Profibus^{®1}, RS485, FlexRay^{®1}, CAN-Bus¹ and RS232.
- Selected inserts can be qualified for data rates.

HOW TO CONFIGURE YOUR HIGH-SPEED CONNECTOR

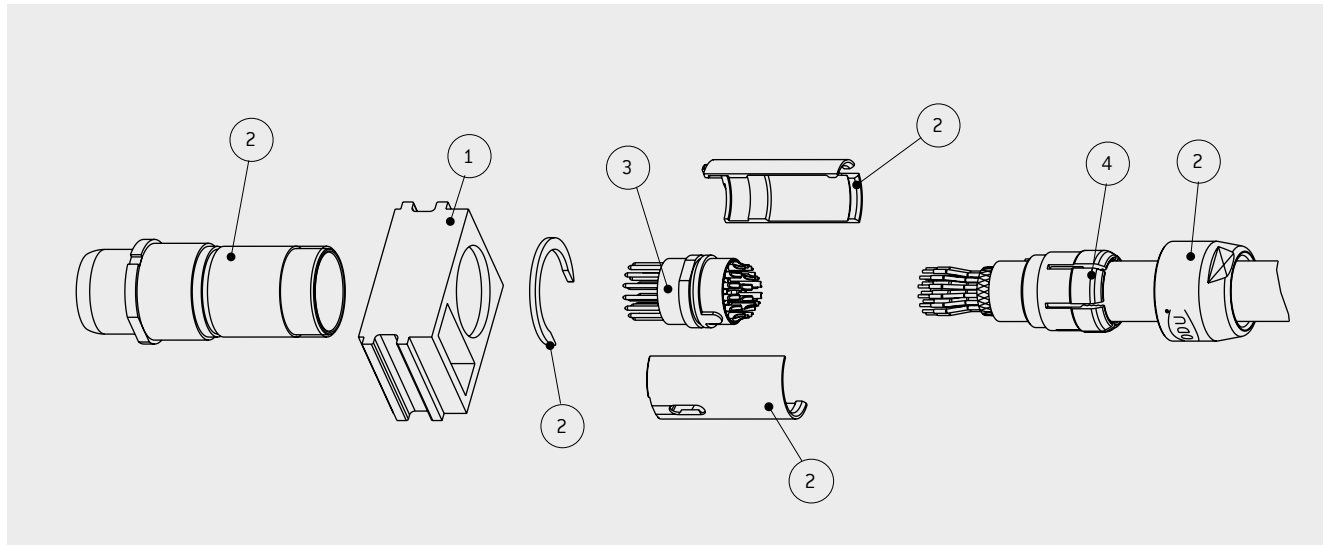

ASSEMBLY SET

Order	Base parts	Part number
1	Insulator	611.171.101.923.000
2	Socket housing complete	653.004.001.304.000
2	Connector housing complete	653.004.002.304.000
3	Insert complete solder contacts ²	see next page
4	Assembly set	see table on the right

Cable Ø mm	Part number
3 to 4.2	753.020.188.304.042
4 to 5.2	753.020.188.304.052
5 to 6.2	753.020.188.304.062
6 to 7.2	753.020.188.304.072
7 to 8.2	753.020.188.304.082
8 to 9.2	753.020.188.304.092
9 to 10.2	753.020.188.304.102

¹Concerning data transmission protocols please note page 2. ²Available with crimp contact upon request.



INSULATOR PIN

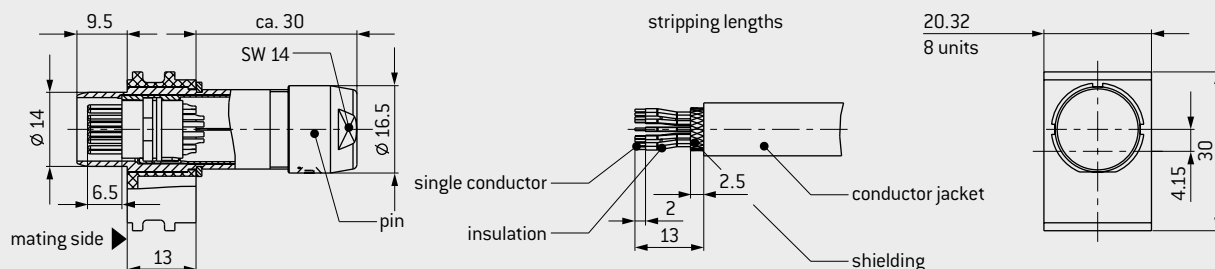

INSULATOR SOCKET

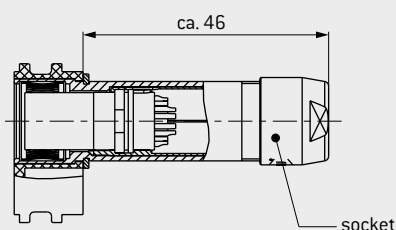

In application with a housing please check the space requirement.

CONTACT ARRANGEMENTS

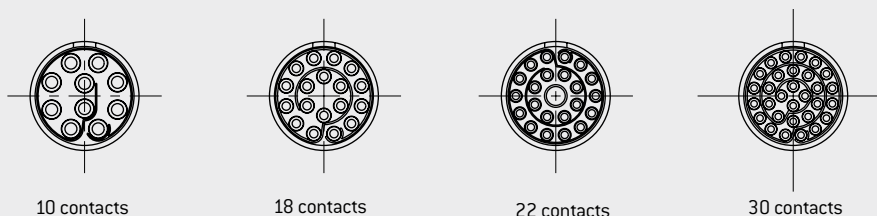

Number of contacts	Contact diameter mm	Termination cross-section AWG	Rated voltage ¹ V	Rated impulse voltage ¹ kV	Degree of pollution ¹	Nominal voltage ² V AC	Model	Category ³	Insert complete ⁴ Part number	Total mating force N	Total sliding force N
--------------------	---------------------	-------------------------------	------------------------------	---------------------------------------	----------------------------------	-----------------------------------	-------	-----------------------	--	----------------------	-----------------------

INSERT WITH ODU TURNTAC® (MATING CYCLES MINIMUM 10,000)

10	1.3	20	20	2	3	450	Pin		703.844.724.010.200	21.6	19.1
			50	2	2		Socket	703.744.724.010.200			
18	0.9	22	10	2	3	450	Pin		703.849.724.018.200	23.3	20.8
			32	2	2		Socket	703.749.724.018.200			
22	0.7	26	32	1.5	2	366	Pin		703.848.724.022.200	21.7	19.7
							Socket	703.748.724.022.200			
30	0.7	26	32	1.5	2	300	Pin		703.848.724.030.200	28.1	24.5
							Socket	703.748.724.030.200			

¹Acc. to IEC 60664-1:2007 (VDE 0110-1:2008), see page 183. ²Acc. to EIA-364-20D:2008, SAE AS 13441:2004 method 3001.1.

³Classification acc. to ISO/IEC 11801:2017. ⁴Several inserts in crimp model on request.

BLANK MODULES



BLANK MODULES



To be used to fill any gaps, in incomplete frames.
The frame has to be fully mounted with insulators, spacers or blank modules.

TECHNICAL DATA

Insulator Thermoplastic
fiber glass reinforced
acc. to UL-94

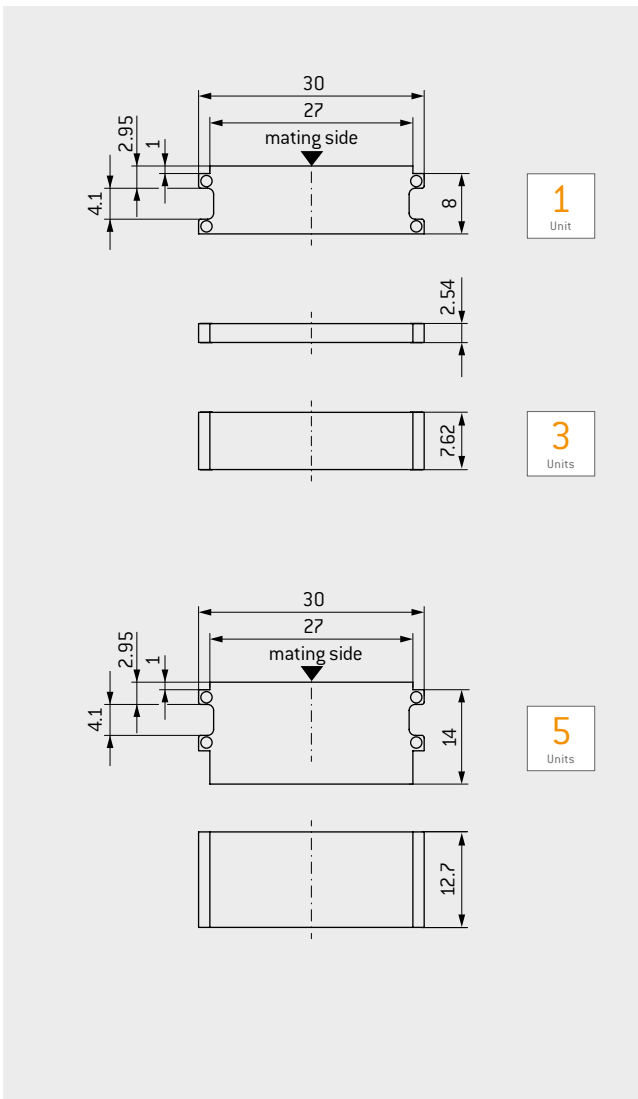

Units	Part number
1	611.122.113.923.000
3	611.130.113.923.000
5	611.128.113.923.000

SPACER MODULES



SPACER MODULES

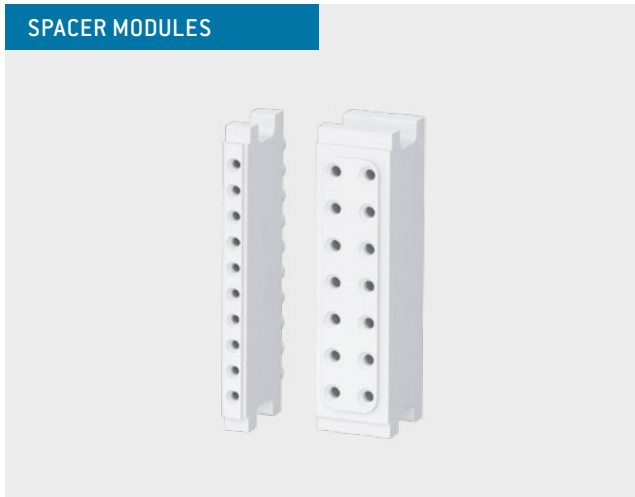

Cannot be retroactively equipped with contacts.
Information on the availability of the individual intermediate pieces can be found with the respective modules.

Supplied without contact arrangements and enable blind mating despite differing contact arrangements. This is the case, for example, with test lanes with various testing scenarios. This means that various tasks can be carried out with one contact arrangement.

TECHNICAL DATA

Insulator	Thermoplastic fiber glass reinforced acc. to UL-94
-----------	--

CODING MODULES



CODING MODULES



Coding modules are placed between the modules to enable coding in addition to the guide system.

TECHNICAL DATA

Insulator Thermoplastic
fiber glass reinforced
acc. to UL-94

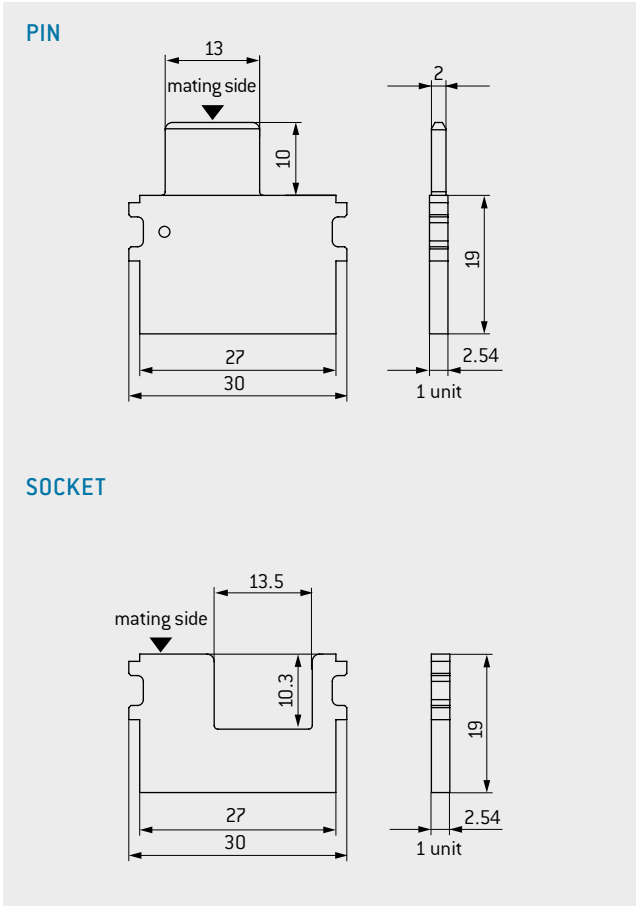

Description	Units	Part number
Coding module (pin)	1	611.161.101.923.000
Coding module (socket)	1	610.161.101.923.000

PIN PROTECTION MODULES



For connections with small pin diameters, these modules serve as protection for the pins. Especially in the case of small contact diameters ($\varnothing 0.76 / 1.02 \text{ mm}$), pin protection modules provide additional protection against unintentional bending of the pins.

TECHNICAL DATA

Insulator Thermoplastic fiber glass reinforced acc. to UL-94

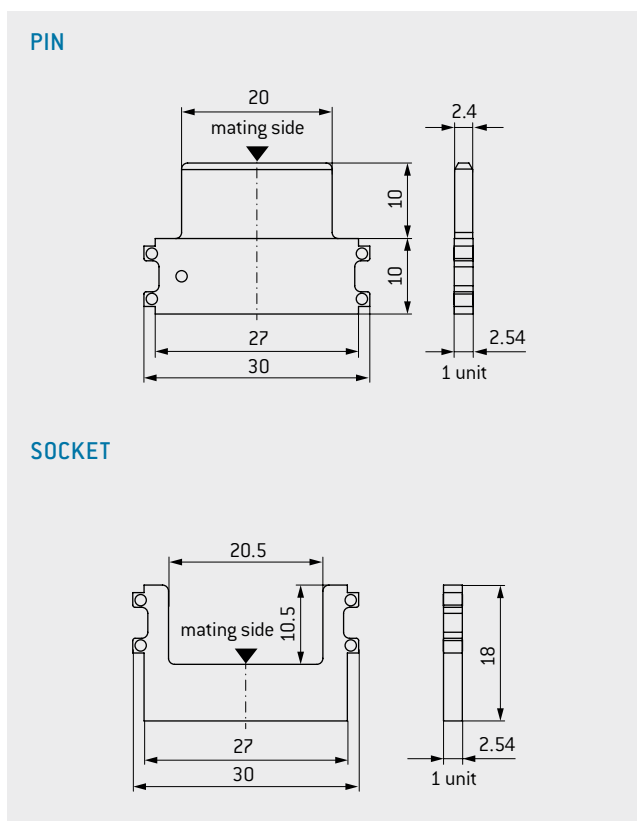

Description	Units	Part number
Pin protection module (pin)	1	611.122.115.923.000
Pin protection module (socket)	1	610.122.115.923.000

Alternatively, these modules can be used to extend clearance and creepage distances.

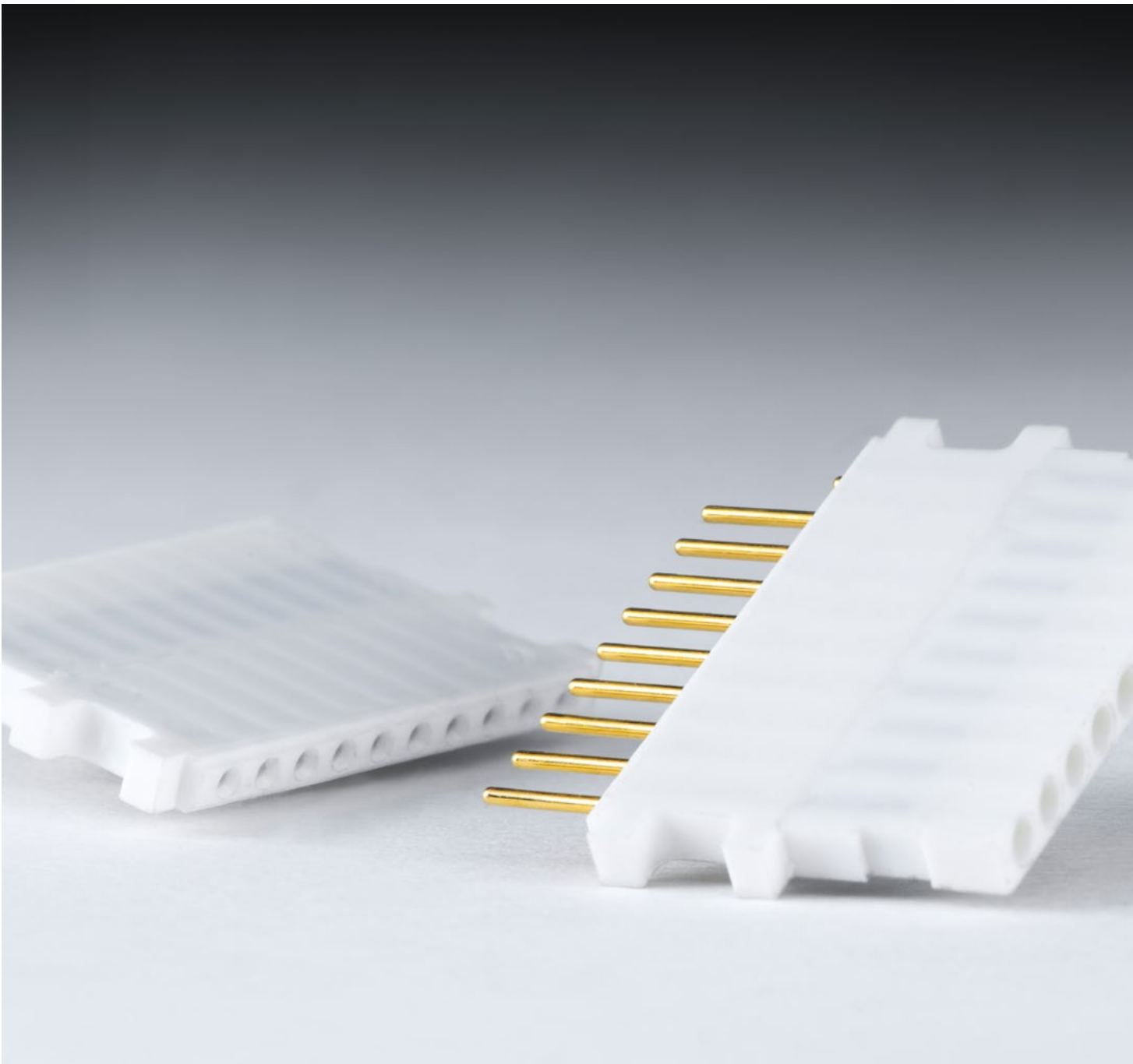

ODU-MAC®

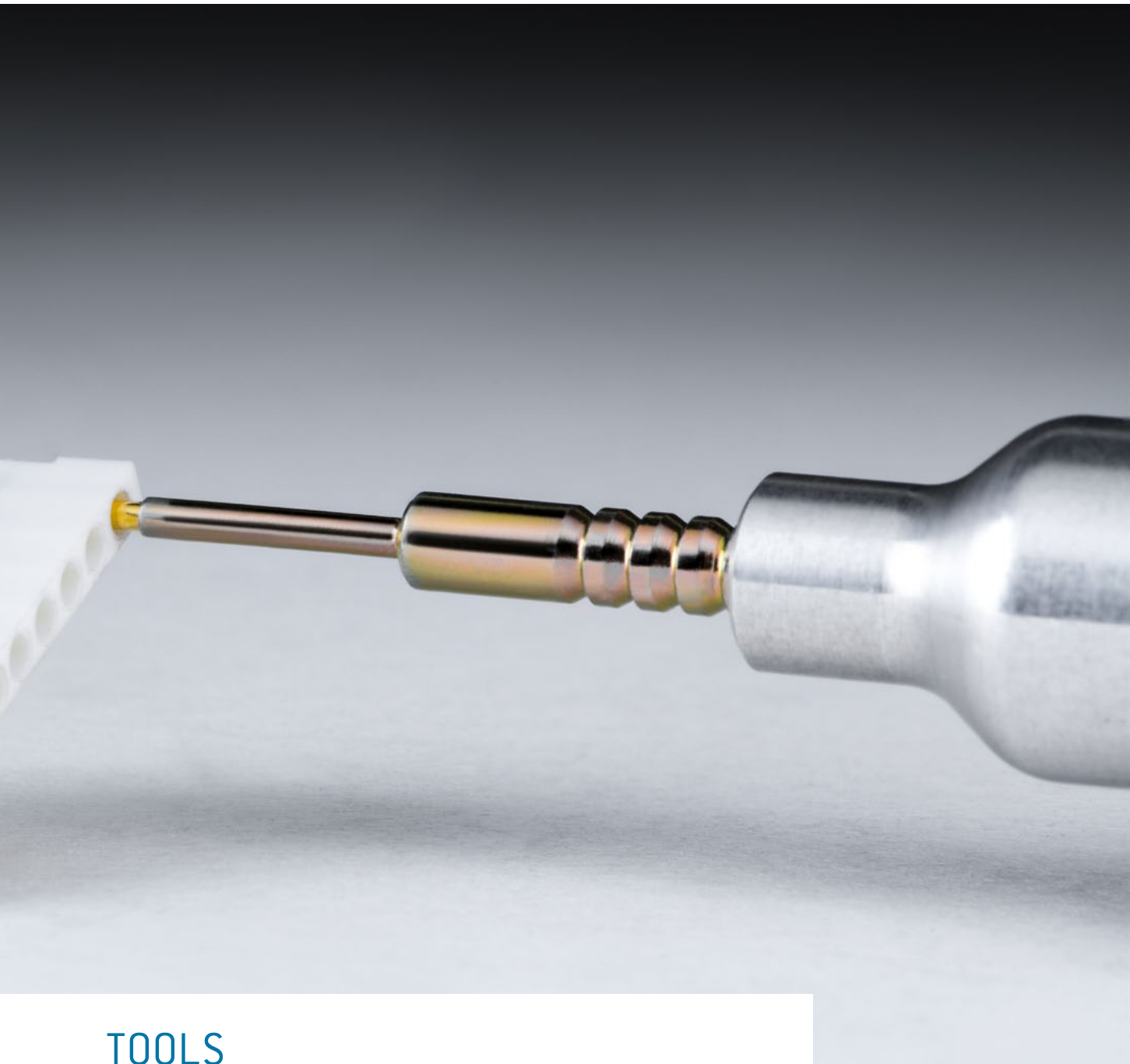

TOOLS

Contact processing and crimping	170
Crimping tools	171
Tensile strength diagram for crimp terminations	173
Crimp information	174
Assembly aid	176
Removal of contacts	178
Maintenance kit	179

TERMINATION TECHNOLOGY



ODU offers three different contact termination technologies for the single contacts:

- Crimp
- Solder
- PCB

CRIMP TERMINATION

Using contacts to establish connecting lines through crimping creates a permanent, secure and corrosion-free connection. For most people, crimping is easy and quick to carry out.

Through crimping, the conductor and contact materials in the compressed areas become so dense as to create a connection which is nearly gas-tight, and with a tensile strength befitting the conductor material.

Crimping can be carried out on the tiniest of diameters as well as in larger diameters. For small diameters (0.08 – 2.5 mm²), eight-point crimp tools are used; six-point crimp tools are used for larger dimensions. The corner measurement of the crimping is never larger than the original diameter. The cable insulation is not damaged in the process and can be directly attached to the connector end.

For error-free crimping, the bore diameter must be perfectly fitted to the cable. Such error-free crimping is only guaranteed if using ODU-recommended crimping tools. In order to correctly advise you, we need to know your cable type and profile, preferably by means of a sample and corresponding data sheet.

HEXAGONAL CRIMPING



8-POINT CRIMPING



FOR ASSEMBLY INSTRUCTIONS PLEASE REFER TO OUR WEBSITE: WWW.ODU-CONNECTORS.COM.

CRIMPING TOOLS



For further crimp information please refer to the table on page 174.

8-POINT CRIMPING TOOL FOR CONDUCTOR CONNECTIONS FROM 0.08 TO 1 mm²



With user-friendly digital display.

PART NUMBER: 080.000.051.000.000

POSITIONER FOR CONTACT DIAMETER FROM 0.76 TO 3 mm

PART NUMBER: 080.000.051.101.000

Has to be ordered separately.

8-POINT CRIMPING TOOL FOR CONDUCTOR CONNECTIONS FROM 1.5 TO 6 mm²



With user-friendly digital display.

PART NUMBER: 080.000.057.000.000

POSITIONER FOR CONTACT DIAMETER FROM 1.5 TO 3 mm

PART NUMBER: 080.000.057.101.000

Has to be ordered separately.

HEXAGONAL CRIMPING TOOL FOR CROSS-SECTIONS (AWG 12), 4 TO 6.0 mm²



With blocking system.

PART NUMBER: 080.000.062.000.000

MECHANICAL HEXAGONAL HAND CRIMPING TOOL FROM 10 TO 50 mm²



PART NUMBER: 080.000.064.000.000

High pressing force with low manual force through precision mechanics. Folding head facilitates processing of unwieldy connector forms and changing of crimp inserts.

CRIMPING JAWS FOR CONTACT DIAMETER FROM 5 TO 12 mm SEE PAGE 175

Has to be ordered separately.

CRIMPING TOOLS



For further crimp information please refer to the table on page 174.

HEXAGONAL CRIMPING TOOL FOR COAX CONTACTS



With blocking system.

PART NUMBER PLIER: 080.000.039.000.000

CRIMPING JAWS PLEASE SEE PAGE 174

Has to be ordered separately.

HAND CRIMPING TOOL FOR SINGLE CRIMP CONTACTS (STAMPED CONTACTS)



PART NUMBER: 080.000.040.000.000

Single contacts are positioned manually in the pliers and get crimped.

HAND CRIMPERS WITH ROLL FOR SPOOL GOODS (STAMPED CONTACTS)



PART NUMBER: 080.000.041.000.000

Contacts are supplied on the reel and are automatically isolated. The feed occurs by hand operation.

- Suitable for coil size: 115 mm. Therefore 500/900 contacts can be processed.
- Processing with automatic stripper crimper possible, further information on request.

CRIMP CONNECTIONS



IEC 60352-2:2013 (DIN EN 60352-2:2014)

Tensile strength diagram of a crimp termination depending upon the conductor cross-section IEC 60352-2:2013 (DIN EN 60352-2:2014). **Example:** A 2.5 mm² conductor must achieve a minimum tensile strength of approx. 320 N.

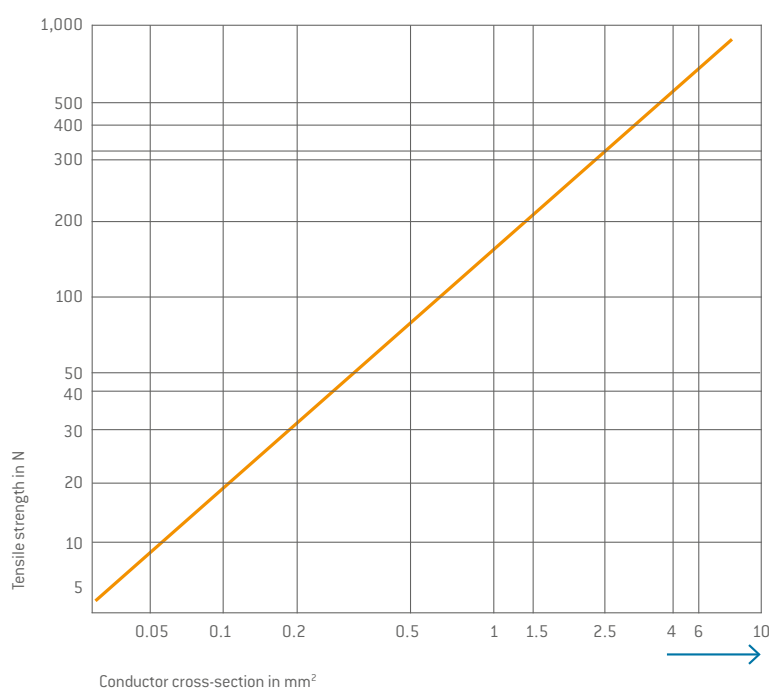

NOTE

Internal standards and guidelines are used for cross-sections (> 10 mm²), as these are not clearly defined in the international standard.

TESTING ELECTRICAL CONTINUITY FOLLOWING ASSEMBLY / TESTING OF WIRING:

One of the most important functional features is the observance of the specified mating and sliding forces. All socket contacts in fully automatic systems supplied by ODU are therefore tested for 100% observance of these values in the context of process monitoring. This takes place with the correctly chosen testing systems without damage to the socket. However, ODU points out that incorrectly chosen test systems (e.g. test pin)

or processing methods (e.g. test speed) following packaging can damage the sockets/pins. Please note the instructions in the assembly instructions (www.odu-connectors.com/downloads/assembly-instructions).

We recommend using suitable test adapters here.



CRIMP INFORMATION



Contact diameter	Termination cross-section ¹		Stripping length	8-pt crimping tool 080.000.051.000.000 without positioner	8-pt crimping tool 080.000.057.000.000 without positioner	Crimping tool for coax 080.000.039.000.000	Hexagonal crimping tool 080.000.062.000.000
	mm	AWG		mm ²	mm	Positioner 080.000.051.101.000 position / adjustment dim.	Positioner 080.000.057.101.000 position / adjustment dim.
0.76	24 – 28	0.25 – 0.08	4 ^{+0.5}	1 / 0.67			
1.02				2 / 0.67			
1.5				3 / 0.67			
0.7	26 – 28		3 ^{+0.5}				
0.7	22 – 24						
0.76	22	0.38	4 ^{+0.5}	1 / 0.67			
1.02	20 – 22	0.5 – 0.38	5 ^{+0.5}	2 / 0.92			
1.5				3 / 0.92			
2.41				4 / 0.92			
3				5 / 0.92			
1.5	18	1 – 0.75	5 ^{+0.5}	3 / 1.12			
2.41				4 / 1.12			
3				5 / 1.12			
1.5	16	1.5	5 ^{+0.5}	3 / 1.42	10 / 1.42 ²		
1.5				3 / 1.32	10 / 1.42 ²		
2.41				4 / 1.32	9 / 1.42 ²		
3				5 / 1.32	6 / 1.42 ²		
1.5	14			5 ^{+0.5}	3 / 1.42	10 / 1.42 ²	
2.41		4 / 1.42	9 / 1.42 ²				
3		5 / 1.42	6 / 1.42 ²				
2.41		2.5	6 ^{+0.5}		9 / 1.67 ²		
3					6 / 1.67 ²		
2.41	12(7 – 20)		6 ^{+0.5}		9 / 2.12 ²		Profile no.2
2.41	12(19 – 26)		6 ^{+0.5}		9 / 1.92 ²		Profile no.2
3		4	6 ^{+0.5}		6 / 2.12 ²		Profile no.3
5							
3	10	6	7 ^{+0.5}		8 / 2.22 ²		Profile no.3
5		10	10 ^{+0.5}				
5		16	10 ^{+0.5}				
8		16	10 ^{+0.5}				
8		25	18 ^{+0.5}				
10							
12							
10		35	18 ^{+0.5}				
12							
12		50	18 ^{+0.5}				
RG 178/RG 196			See module description (9/4.5/18.5)			082.000.039.101.000	
RG 174/RG 188/RG 316/RG 179/RG 187						082.000.039.102.000	
G 02232 D/K 02252 D						082.000.039.103.000	
RG 122/2YCY 0.4/2.5						082.000.039.104.000	
RG 58/G 03233 (H&S)						082.000.039.106.000	
RG 223						082.000.039.108.000	
RG 59						082.000.039.109.000	

CRIMP INFORMATION



Contact diameter mm	Termination cross-section ¹		Stripping length mm	Hexagonal crimping tool 080.000.064.000.000	Hand crimping tool stamped contacts	Hand crimping tool stamped contacts	
	AWG	mm ²		Pressbacken		Spool goods	
0.76	24-28	0.25-0.08	4 ^{+0.5}				
1.02							
1.5							
0.7	26-28		3 ^{+0.5}		080.000.040.000.000	080.000.041.000.000	
0.7	22-24			080.000.040.000.000	080.000.041.000.000		
0.76	22	0.38	4 ^{+0.5}				
1.02	20-22	0.5-0.38	5 ^{+0.5}				
1.5							
2.41							
3							
1.5	18	1-0.75	5 ^{+0.5}				
2.41							
3							
1.5	16		5 ^{+0.5}				
1.5		1.5	5 ^{+0.5}				
2.41							
3							
1.5	14		5 ^{+0.5}				
2.41							
3							
2.41		2.5	6 ^{+0.5}				
3							
2.41							
2.41	12(7-20)		6 ^{+0.5}				
2.41	12(19-26)		6 ^{+0.5}				
3	10	4	6 ^{+0.5}				
5							
3							
5		10	10 ^{+0.5}	080.000.064.110.000			
5		16	10 ^{+0.5}	080.000.064.101.000			
8		16	10 ^{+0.5}	080.000.064.116.000			
8		25	18 ^{+0.5}	080.000.064.125.000			
10							
12							
10		35	18 ^{+0.5}	080.000.064.135.000			
12							
12							
12		50	18 ^{+0.5}	080.000.064.150.000			

¹ The listed cross section correspond to a finely stranded conductor design according to IEC 60228:2005 (VDE 0295:2005) class 5 or a finely stranded conductor design (7/19-stranded) according to AWG ASTM B258-14). ² Recommended by ODU as a standard tool and setting.

ASSEMBLY AID



Description	Usage for	Part number	Nm	Recommended tightening torque
Torque wrench With cross handle. fixed. automatic release (for inner hexagonal bits with C6.3- or E6.3-shaft). Bit has to be ordered separately.		598.054.001.000.000	0.9	
		598.054.002.000.000	1.2	
		598.054.003.000.000	3	
		598.054.004.000.000	1.5	
		598.054.005.000.000	0.6	
		598.054.006.000.000	2.2	
		598.054.007.000.000	4.2	
Bit slot 2.5 (0.4/70)	Mounting of spindle coding	598.054.109.000.000		0.9 Nm +/- 0.2 Nm
Bit slot 3.5 (0.5/50)	Screwing of the rails in the T frame	598.054.108.000.000		0.9 Nm +/- 0.2 Nm
Bit slot 5.5 (0.8/50)	Screwing of the rails in the L frame	598.054.101.000.000		1.2 Nm +/- 0.2 Nm
Bit slot 8 (1.2/50)	Mounting of frame coding (coded socket)	598.054.110.000.000		1.2 Nm +/- 0.2 Nm
Special bit	Coding pin for frames in a housing	598.054.203.000.000		1.2 Nm +/- 0.2 Nm
Bit combi slot size 1	Mounting screw on frames in a housing	598.054.102.000.000		1.2 Nm +/- 0.2 Nm
Bit Phillips cross slot size 1	Grounding screw on frames in a housing and M+/S+ frame	598.054.106.000.000		1.2 Nm +/- 0.2 Nm
Bit Phillips cross slot size 1	Grounding plug socket for P+ frame	598.054.106.000.000		1.5 Nm +/- 0.2 Nm
Bit Phillips cross slot size 1	Grounding pin for P+ frame	598.054.106.000.000		3.0 Nm +/- 0.3 Nm
SW 8	Mounting of grounding socket P+ frame	598.054.111.000.000		2.2 Nm +/- 0.3 Nm
SW 8	Mounting of grounding pin P+ frame	598.054.111.000.000		4.2 Nm +/- 0.5 Nm
Bit Torx TX 8	Rails on frames in a housing	598.054.103.000.000		0.9 Nm +/- 0.2 Nm
Bit Torx TX 10	Screwing of the rails in the S and M+/S+ frame and spare spindle knob and PE-module	598.054.104.000.000		1.2 Nm +/- 0.2 Nm
Bit Torx TX 10	Mounting of ODU-MAC ZERO housing	598.054.104.000.000		0.6 Nm +/- 0.1 Nm
Bit Torx TX 20	Screwing of the rails in the P+ frame/ contact PE-module	598.054.105.000.000		3.0 Nm +/- 0.3 Nm
Bit for coding pin	Mounting of coding pins	598.054.203.000.000		1.2 Nm +/- 0.2 Nm
Distance spacer/QCH	S frame for quick-change head and rear mounting panel	598.054.204.000.000		1.2 Nm +/- 0.2 Nm
Receiving of back nut	Mounting, shielded implementation size 0	598.055.002.000.000		0.6 Nm +/- 0.1 Nm
Receiving of back nut	Mounting, shielded implementation size 1	598.055.001.000.000		1.0 Nm +/- 0.2 Nm
Receiving of back nut	Mounting, shielded implementation size 2	598.055.003.000.000		2.0 Nm +/- 0.2 Nm
Receiving of back nut	Mounting, shielded implementation size 3	598.055.004.000.000		3.5 Nm +/- 0.3 Nm

ASSEMBLY AID

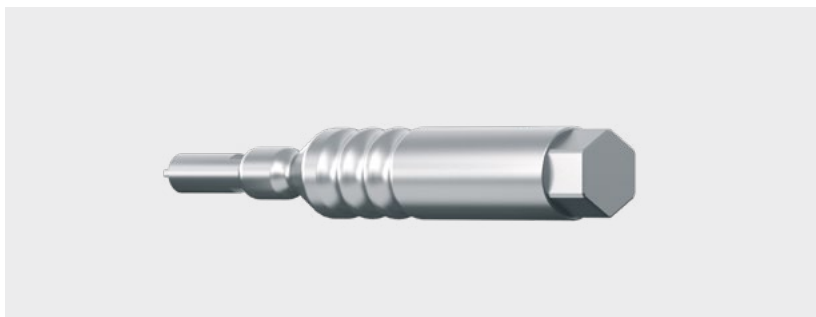

ASSEMBLY TOOL HIGH CURRENT

Necessary assembly tool for screwing and releasing of the contacts.

PART NUMBER: 087.611.00_001.000

With _ please register the respective figure for contact diameter 8 to 12 mm.

See table below.

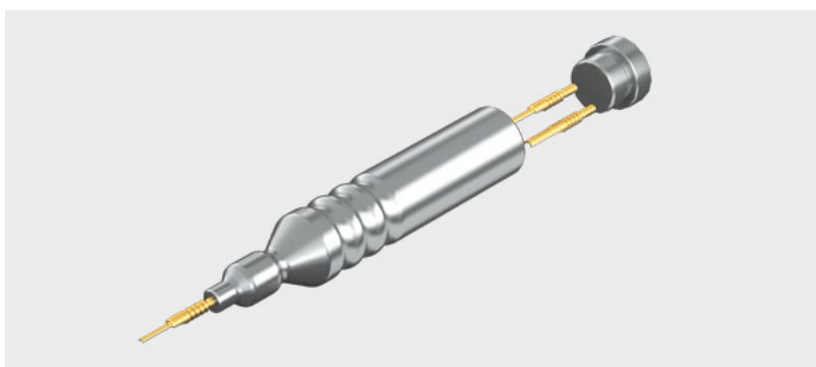

INSERTION TOOL Ø 0.76–1.5 mm

For assembly aid of contacts with flexible/ thin conductors (pin and socket side).

PART NUMBER: 085.611.001.001.000

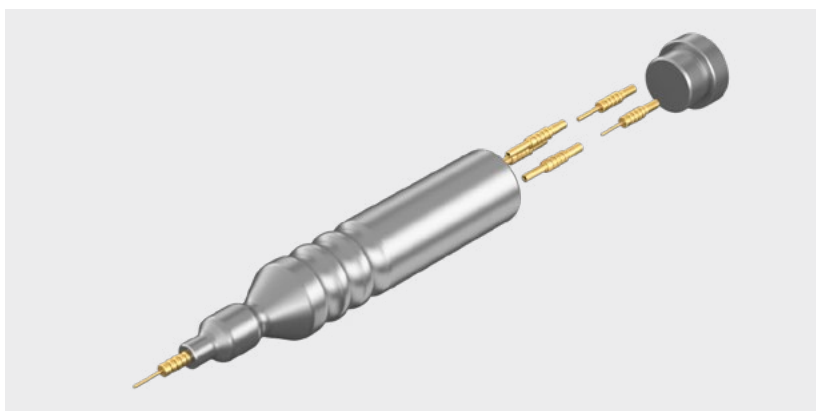

EXTRACTION TOOL Ø 0.76–1.5 mm

Extraction tool for sockets and pins by use of the removal tool.

PART NUMBER: 087.611.005.001.000

Contact Ø	Assembly tool high current	Assembly aid insertion tool	Assembly aid extraction tool
0.76		085.611.001.001.000	087.611.005.001.000
1.02		085.611.001.001.000	087.611.005.001.000
1.5		085.611.001.001.000	087.611.005.001.000
8	087.611.002.001.000		
10	087.611.003.001.000		
12	087.611.004.001.000		

REMOVAL AND ASSEMBLY OF CONTACTS IS ONLY POSSIBLE WITH ODU TOOLS.

REMOVAL OF CONTACTS



REMOVAL TOOL I

Removal of the already assembled contact (incl. cable): The removal tool is pressed from behind into the insulator until a quiet click is heard. The contact is removed from the insulator by pulling on the cable or by lightly pressing the contact with the extraction tools.

REMOVAL TOOL II

Removal of unassembled contacts, or contacts from which the cable has been removed. The removal tool is pressed from behind into the insulator until a quiet click is heard. The contact can be removed from the insulator by lightly pushing it with the extraction tools.

REMOVAL ONLY POSSIBLE WITH ODU TOOLS.

Contact Ø	Removal tool I straight	Removal tool I angled	Removal tool II	Removal tool	Removal tool
0.76 ²		087.170.361.000.000	087.611.001.001.000		
1.02 ²		087.170.362.000.000	087.611.001.001.000		
1.5 ²	087.170.138.000.000	087.170.363.000.000 ¹	087.611.001.001.000		
2.41	087.170.139.000.000	087.170.365.000.000	087.611.001.001.000		
3	087.170.136.000.000	087.170.366.000.000	087.611.001.001.000		
5				087.170.391.000.000	
Coax 50Ω 4 contacts	087.170.139.000.000	087.170.365.000.000	087.611.001.001.000 ²		
Coax 50Ω 2 contacts				087.170.391.000.000	
Coax 50Ω 2 contacts SMA				087.122.349.000.000	
Coax 75Ω 2 contacts				087.170.391.000.000	
Fiber optic 5 contacts					087.611.001.002.000
Fiber optic 3 contacts	087.170.136.000.000		087.611.001.001.000		

¹ In use with high voltage module, 4 contacts, (see page 126) the angled version cannot be used.

² With cable (H+S) G02232 only removal tool I is usable.

MAINTENANCE PACKAGE FOR ODU SPRINGTAC® AND ODU LAMTAC® CONTACTS



Contact lubrication improves the mechanical properties of contact systems. Cleaning the contact surfaces prior to lubrication is also recommended in order to remove pollution. With appropriate care, wear due to high mating frequency can be significantly minimised and the mating and unmating forces reduced. The cleaning and lubricating interval must be individually adapted to circumstances and should only be carried out with products recommended by the contact manufacturer.

ODU has put together a maintenance package to this purpose, so that lubrication can be carried out directly on location. A cleaning brush and a special cleaning cloth, as well as precise instructions allow optimal care of the contacts. In the absence of other specifications, the maintenance package can be used for all ODU contacts and connections.

PART NUMBER: 170.000.000.000.100

For technical properties of the maintenance package please refer our website: www.odu-connectors.com/downloads.

CLEANING INFORMATION

Maintenance instruction 003.170.000.000.000

FURTHER INFORMATION

Never submerge the connector in liquid. The connector may only be put back into operation again when it has been assured that it is completely dry.

Ensure that contact pins are not bent or otherwise damaged. The connector may no longer be used when damage or other signs of wear are detected. Clean with maximum 2.5 bar compressed air to avoid contact damage. A slight blackening of the contact points may occur over the course of the service life and represents no impairment of the electrical properties.

Recommended cleaning agent

Soap: liquid soaps on sodium bicarbonate or potassium base.

Alcohol: ethanol 70%, isopropyl alcohol 70%.



ODU-MAC®

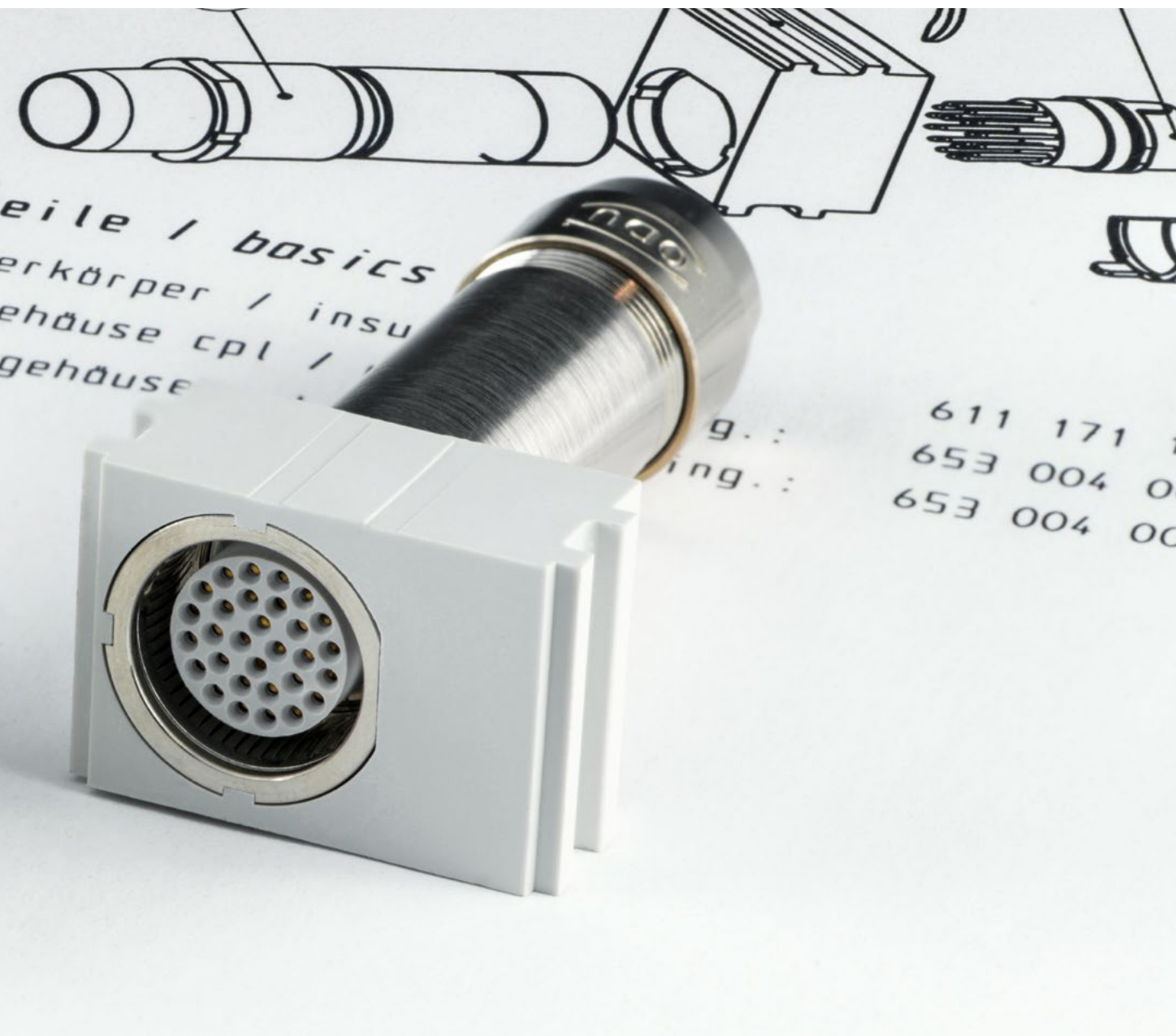

TECHNICAL INFORMATION

International protection classes acc. IEC 60529:2013 (VDE 0470-1:2014)	182
Explanations and information according to VDE	184
Conversions / AWG	186
Operating voltage according to EIA-364-20D:2008	187
Current-carrying capacity	188
Technical terms	193

INTERNATIONAL PROTECTION CLASSES



Acc. IEC 60529:2013 (VDE 0470-1:2014).

Code letters (International Protection)		First code number (Degrees of protection against access to hazardous parts respectively against solid foreign objects)		Second code number (Degrees of protection against water)		
IP		6		5		
Code number	Protection against access to hazardous parts / Protection against ingress of solid foreign objects			Code number	Protection against harmful effects due to the ingress of water	
0	No protection		No protection against contact / No protection against solid foreign objects	0	No protection against water	No protection against water
1	Protection against large foreign objects		Protection against contact with the back of the hand / Protection against solid foreign objects $\varnothing \geq 50$ mm	1	Protection against dripping water	Protection against vertically falling waterdrops
2	Protection against medium-sized foreign objects		Protection against contact with the fingers / Protection against solid foreign objects $\varnothing \geq 12.5$ mm	2	Protection against dripping water (tilted)	Protection against falling waterdrops when tilted (any angle up to 15° from the vertical)
3	Protection against small foreign objects		Protection against contact with tools / Protection against solid foreign objects $\varnothing \geq 2.5$ mm	3	Protection against spray water	Protection against spray water (any angle up to 60° from the vertical)
4	Protection against granular foreign objects		Protection against contact with a wire / Protection against solid foreign objects $\varnothing \geq 1.0$ mm	4	Protection against splashing water	Protection against splashing water from all directions
5	Dustproof		Protection against contact with a wire / Protection against uncontrolled ingress of dust	5	Protection against water jet	Protection against water jet from all directions
6	Dustproof		Protection against contact with a wire / Complete protection against ingress of dust	6	Protection against powerful water jet	Protection against powerful water jet from all directions
				7	Protection against the effects of temporary immersion in water	Protection against ingress of harmful quantities of water by temporary submersion into water
				8	Protection against the effects of continuous immersion in water	Protection against ingress of harmful quantities of water by continuous submersion into water
				9	Protection against high pressure and high water jet temperatures	Protection against water from all directions by high pressure and high temperatures

EXPLANATIONS AND INFORMATION ON INSULATION COORDINATION



IEC 60664-1:2007 (VDE 0110-1:2008): TABLE F.1 – RATED SURGE VOLTAGE FOR OPERATING MEDIA FED DIRECTLY FROM THE LOW VOLTAGE MAINS.

Nominal voltage of the power supply system (network) acc. to IEC 60038:2009 (VDE 0175-1:2012)		Voltage conductor to neutral conductor derived from nominal voltages a.c. or d.c. up to and including V	Rated impulse voltage Overvoltage category			
Three-phase-system V	Single-phase-system V		I V	II V	III V	IV V
		50	330	500	800	1,500
		100	500	800	1,500	2,500
	120 to 240	160	800	1,500	2,500	4,000
230/400 277/480		300	1,500	2,500	4,000	5,000
400/692		600	2,500	4,000	6,000	8,000
1,000		1,000	4,000	6,000	8,000	12,000

APPLICABLE STANDARDS

IEC 60664-1:2007 (VDE 0110-1:2008) and IEC 61984:2008 (VDE 0627:2009), original (IEC 60664-1:2007 VDE 0110-1:2008) and IEC 61984:2008 (VDE 0627:2009) remains definitive for all of the technical information named).

GENERAL

The selection of a connector cannot only take functionality, number of contacts, current or voltage parameters into account. In fact, consideration of the place of use and the installation conditions prevailing there is indispensable. Depending upon the installation and ambient conditions, the connector can be used in accordance with the standards in a variety of voltage and current ranges. All of the voltage data listed in this catalog refers to the use of insulators in the ODU-MAC solid frame for housings or in the ODU-MAC docking frame. All of the connectors shown here involve connectors without contact rating (COC) in accordance with IEC 61984:2008 (VDE 0627:2009).

The most important influence variables and the electrical parameters harmonised with these will be explained in more detail in the following. Our technicians would be happy to assist you with any further questions. The following texts and tables are excerpts from the indicated standards.

OVERVOLTAGE CATEGORY

The necessary rated surge voltage is defined through the overvoltage category according to table F.1 together with the nominal voltage used. Depending upon the installation location, the respective overvoltage category is selected according to the criteria listed below for operating media that is fed directly from the low voltage mains.

Overvoltage category I

Operating media for connection to circuits in which measures for limiting the transient overvoltages to an appropriately low value have been taken. For example, connectors for the voltage supply of computer hardware permanently connected to a power supply with electronic overvoltage limitation.

Overvoltage category II

Operating media fed by the fixed installation that consume energy. For example, household devices, portable tools and similar devices.

Overvoltage category III

(= standard, when no special overvoltage category is indicated)
Operating media in permanent installations and cases for which special requirements for reliability and availability of the operating media exist. For example, switches in permanent installations and operating media for industrial use with permanent connection to the permanent installation.

Overvoltage category IV

Operating media for use at the termination point of the installation. For example, electricity meters and primary overcurrent protection devices.

EXPLANATIONS AND INFORMATION ACCORDING TO VDE



DEGREE OF POLLUTION

Potentially occurring pollution combined with moisture can influence the insulation capacity on the surface of the connector. In order to define various rating parameters, a degree of pollution according to the criteria listed below must be selected for the operating medium.

In the case of a connector with a degree of protection of minimum IP 54 IEC 60529:2013 (VDE 0470-1:2014), the insulating parts may be measured enclosed according to the standard for a low degree of pollution. This also applies for mated connectors for which enclosure is ensured by the connector housing and which are only disconnected for testing and maintenance purposes.

Degree of pollution 1

No or only dry, non-conductive pollution is present. The pollution has no influence. For example, computer systems and measuring devices in clean, dry or air-conditioned rooms.

Degree of pollution 2

Only non-conductive pollution is present. However, temporary conductivity due to condensation must be anticipated. For example, devices in laboratories, residential, sales and other business areas.

Degree of pollution 3

(= standard, when no special degree of pollution is indicated)
Conductive pollution occurs or dry, non-conductive pollution that becomes conductive because of dewfall must be expected. For example: Devices in industrial, commercial and agricultural operations, unheated storage areas and workshops.

Degree of pollution 4

Permanent conductivity is present, caused by conductive dust, rain or moisture. For example, devices in the open air or outdoor facilities and construction machinery.

Operating voltage (VDE : Rated voltage): Value of a voltage that is specified by the manufacturer for a component, device or operating medium and relates to the operating and performance features.

Depending upon the indicated degree of pollution, the rated voltage is dependent upon the insulating material group of the connector and the respective creepage distances between the individual contacts. The rated voltage may be significantly influenced by the use of blank modules and varying positioning of the contacts in the insulator. Operating media may have more than one value or one range for rated voltage (see table F.4 in IEC 60664-1:2007 (VDE 0110-1:2008)).

NOMINAL VOLTAGE

A suitably rounded voltage value indicated by the manufacturer for the designation or identification of an operating medium. In these explanations, the term nominal voltage is used for the value of the issued voltage indicated by the power supply company (PSC) or by the manufacturer of the voltage source for classification of the overvoltage category.

RATED IMPULSE VOLTAGE

Value of an impulse withstand voltage that is indicated by the manufacturer for an operating medium or a part of this, and which indicates the defined endurance of its insulation against transient (brief, duration of a few milliseconds) overvoltages. The impulse withstand voltage is the highest value of the surge voltage of a defined form and polarity which will not result in the dielectric breakdown of the insulation under defined conditions.

Depending upon the indicated degree of pollution, the rated surge voltage depends upon the clearance distance between the individual contacts. The rated surge voltage may be influenced significantly by the usage of blank modules and varied positioning of the contacts in the insulators, (see table F.2 in IEC 60664-1:2007 (VDE 0110-1:2008)).

In the most recent edition of IEC 60664-1:2007 (VDE 0110-1:2008), the minimum clearance distances for operating media not connected directly to the low voltage mains should be measured according to the possible permanent voltages, the temporary overvoltages or periodic peak voltages (see table F.7 in IEC 60664-1:2007 (VDE 0110-1:2008)).



IMPULSE TEST VOLTAGE / POWER FREQUENCY TEST VOLTAGE

Highest value of the surge voltage of a defined form and polarity that will not result in a dielectric breakdown or flashover of the insulation under defined conditions.

CLEARANCE DISTANCE

The shortest distance in the air between two conductive parts.

CREEPAGE DISTANCE

The shortest distance between two conductive parts over the surface of an insulation material. The creepage distance is influenced by the degree of pollution applied.

TEST VOLTAGE

The dielectric strength of the connector is confirmed according to the standard corresponding to the indicated rated surge voltage by applying the test voltage according to table F.5 over a defined time range.

IEC 60664-1:2007 [VDE 0110-1:2008]: table F.5 – test voltages for testing clearance distances at different altitudes (the voltage levels are valid only to verify the clearance distances).

Rated impulse voltage ú kV	Test impulse voltage at sea level ú kV	Test impulse voltage at 200 m elevation ú kV	Test impulse voltage at 500 m elevation ú kV
0.33	0.357	0.355	0.350
0.5	0.541	0.537	0.531
0.8	0.934	0.920	0.899
1.5	1.751	1.725	1.685
2.5	2.920	2.874	2.808
4	4.923	4.874	4.675
6	7.385	7.236	7.013
8	9.847	9.648	9.350
12	14.770	14.471	14.025

CONVERSIONS/AWG (AMERICAN WIRE GAUGE)



Circular wire					
AWG	Diameter		Cross-section mm ²	Weight kg/km	Max. resistance Ω/km
	Inch	mm			
4/0 [259/21]	0.6010	15.300	107.0	997.00	0.17
3/0 [259/22]	0.5360	13.600	85.0	793.00	0.22
2/0 [259/23]	0.4770	12.100	67.4	628.00	0.27
1/0 [259/24]	0.4240	10.800	53.5	497.00	0.34
1 [259/25]	0.3780	9.600	42.2	395.00	0.43
2 [259/26]	0.3350	8.500	33.6	312.00	0.55
4 [133/25]	0.2660	6.800	21.1	195.00	0.87
6 [133/27]	0.2100	5.300	13.3	122.00	1.38
8 [133/29]	0.1670	4.200	8.37	76.80	2.18
10 [1]	0.1019	2.590	5.26	46.77	3.45
10 [37/26]	0.1150	2.921	4.74	42.10	4.13
12 [1]	0.0808	2.050	3.31	29.41	5.45
12 [19/25]	0.0930	2.362	3.08	27.36	5.94
12 [37/28]	0.0910	2.311	2.97	26.45	6.36
14 [1]	0.0641	1.630	2.08	18.51	8.79
14 [19/27]	0.0730	1.854	1.94	17.23	9.94
16 [1]	0.0508	1.290	1.31	11.625	13.94
16 [19/29]	0.0590	1.499	1.23	10.928	15.70
18 [1]	0.0403	1.020	0.823	7.316	22.18
20 [1]	0.0320	0.813	0.519	4.613	35.10
20 [7/28]	0.0390	0.991	0.563	5.003	34.10
20 [19/32]	0.0420	1.067	0.616	5.473	32.00
22 [1]	0.0253	0.643	0.324	2.883	57.70
22 [19/34]	0.0330	0.838	0.382	3.395	51.80
24 [1]	0.0201	0.511	0.205	1.820	91.20
24 [7/32]	0.0250	0.635	0.227	2.016	86.00
24 [19/36]	0.0270	0.686	0.241	2.145	83.30
26 [1]	0.0159	0.404	0.128	1.139	147.00
26 [7/34]	0.0200	0.508	0.141	1.251	140.00
26 [19/38]	0.0220	0.559	0.154	1.370	131.00
28 [1]	0.0126	0.320	0.0804	0.715	231.00
28 [7/36]	0.0160	0.406	0.0889	0.790	224.00
28 [19/40]	0.0170	0.432	0.0925	0.823	207.00
30 [1]	0.0100	0.254	0.0507	0.450	374.00
30 [7/38]	0.0130	0.330	0.0568	0.505	354.00
32 [1]	0.0080	0.203	0.0324	0.288	561.00
32 [7/40]	0.0110	0.279	0.0341	0.303	597.10
34 [1]	0.0063	0.160	0.0201	0.179	951.00
34 [7/42]	0.0070	0.180	0.0222	0.197	1,491.00
36 [1]	0.0050	0.127	0.0127	0.1126	1,519.00
36 [7/44]	0.0060	0.150	0.0142	0.1263	1,322.00

The American Wire Gauge (AWG) is based on the principle that the cross-section of the wire changes by 26% from one gauge number to the next. The AWG numbers decrease as the wire diameter increases, while the AWG numbers increase as the wire diameter decreases. This only applies to solid wire.

However, stranded wire is predominately used in practice. This has the advantage of a longer service life under bending and vibration as well as greater flexibility in comparison with solid wire.

Stranded wires are made of multiple, smaller-gauge wires (higher AWG number). The stranded wire then receives the AWG numbers of a solid wire with the next closest cross-section to that of the stranded wire. In this case, the cross-section of the stranded wire refers to the sum of the copper cross-sections of the individual wires.

Accordingly, strands with the same AWG number but different numbers of wires differ in cross-section. For instance, an AWG 20 strand of 7 AWG 28 wires has a cross-section of 0.563 mm², while an AWG 20 strand of 19 AWG 32 wires has a cross-section of 0.616 mm².

Source: ASTM

OPERATING VOLTAGE



EIA-364-20D:2008 [SAE AS 13441:2004 method 3001.1].

The values specified in the catalog correspond to SAE AS 13441:2004 method 3001.1. The table values were determined according to EIA 364-20D:2008. The inserts were tested while mated, and the test current was applied to the pin insert.

75% of the dielectric withstanding voltage is used for the further calculation. The operating voltage is 1/3 of this value.

All tests were conducted at normal indoor climate and apply up to an altitude of 2,000 m. If there are any deviations, the derating factors are to be factored in according to the applicable standards.

Test voltage: Dielectric withstanding voltage $\times 0.75$

Operating voltage: Dielectric withstanding voltage $\times 0.75 \times 0.33$

ATTENTION:

With certain applications, the safety requirements for electrical devices are very strict in terms of operating voltage. In such cases, the operating voltage is defined according to the clearance and creepage distances between parts which could be touched.

When selecting such a connector, please contact us and let us know the safety standard which the product must meet.

BASE FOR CURRENT-CARRYING CAPACITY



Derating measurement procedure IEC 60512-5-2:2002 (DIN EN 60512-5-2:2003).

STRUCTURE OF THE BASE CURRENT-CARRYING CAPACITY CURVE

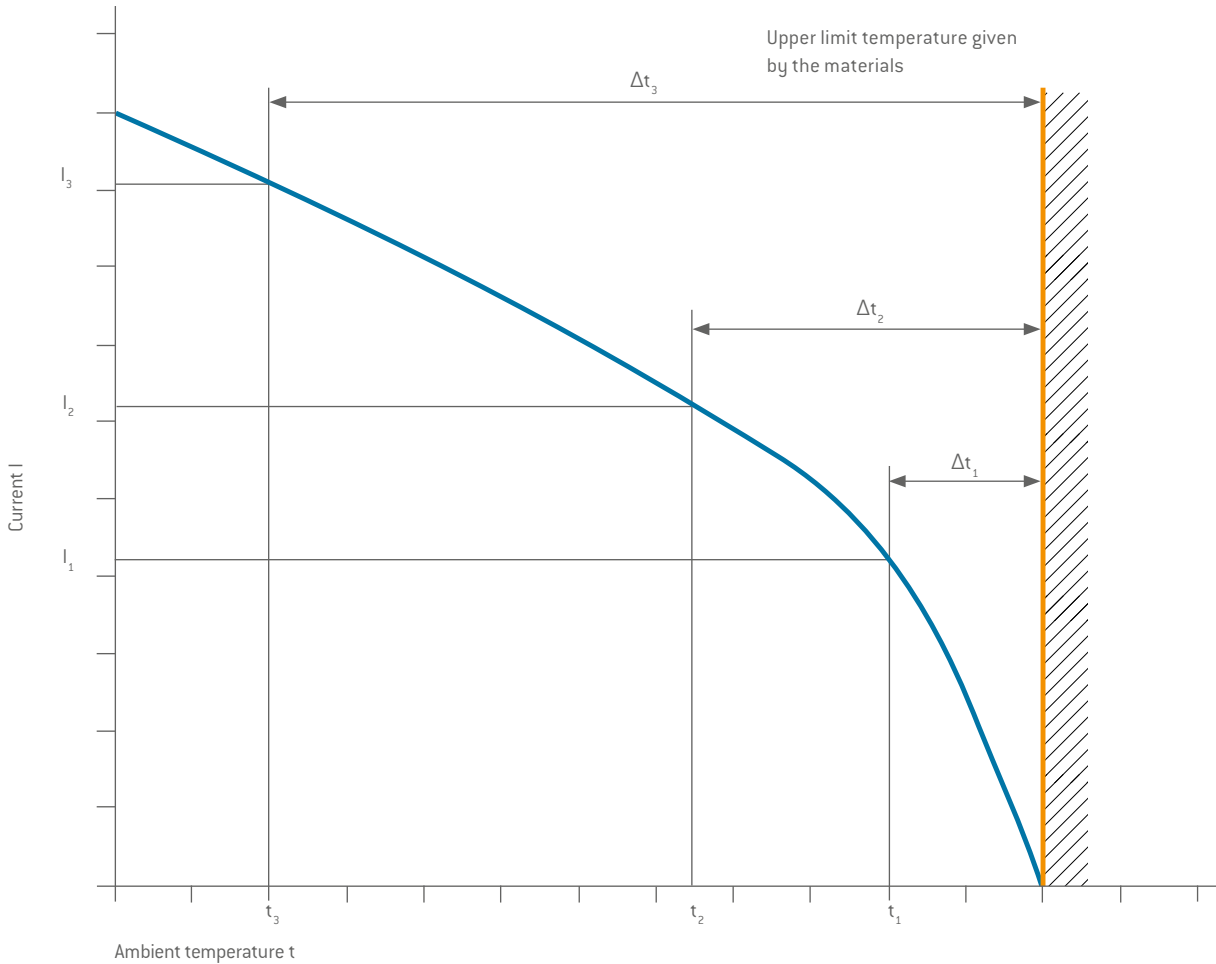

A current-carrying capacity curve metrologically determined according to the method described in IEC 60512-5-2:2002 (DIN EN 60512-5-2:2003) depending on the permissible limit temperature of the materials.

The current-carrying capacity of a connector is determined by measurement. It is determined taking self-heating by Joule heat and the ambient temperature into account, and is limited by the thermal properties of the contact materials used. Their upper limit temperature may not be exceeded in the process.

The relationship between current, the resulting temperature increase, conditioned by the dissipation loss at the contact resistance, and the ambient temperature is represented in a

curve. The curve is plotted in a linear coordinate system with current “ I ” as Y-axis and temperature “ t ” as X-axis. The upper limiting temperature forms the limit of the diagram.

Over three measurements, the temperature rise due to Joule heat (Δt) is measured respectively for different currents on minimum three connectors, and the resulting values are joined to produce the parabolic basic curve. The basic curve is then used to derive the corrected current-carrying capacity curve (derating curve). The safety factor ($0.8 \times I_n$) also makes allowance for factors such as manufacturing tolerances and uncertainties in temperature measurement or the measuring arrangement.

CURRENT LOAD



[In dependence on VDE 0276-1000:1995].

RATED CURRENT (NOMINAL CURRENT)

The metrologically determined current which is permitted to flow continuously through all contacts at the same time and will increase the contact temperature by 45 Kelvin. The amperage is determined according to the derating measurement method (DIN EN 60512-5-2:2003) and derived from the derating curve. The values specified in the catalog apply to either individual contacts or completely assembled inserts/modules, as indicated.

DERATING FACTORS

In the case of multi-position connectors and cables, heating is greater than with individual contacts. It is therefore calculated with a derating factor.

There are no direct regulations for connectors in this context. The derating factors for multi-core cables pursuant to VDE 0298-4:2013 are applied. The derating factor assumes relevance as of 5 live wires.

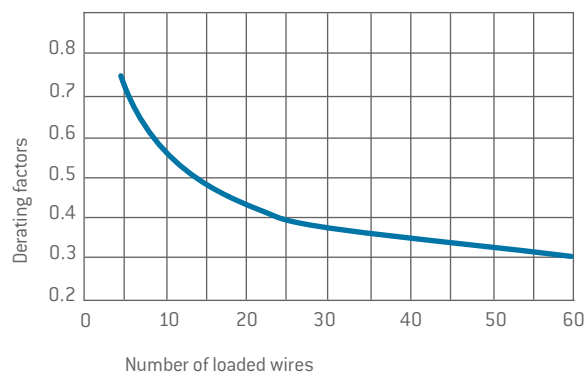

Example:

VA cable with 24 wires is used (24 contacts). The nominal cross-section of a wire is 6 mm². A derating factor of 0.4 (e.g. cable installed in the open air) is to be presumed for the load reduction depending upon the number of live cable wires. A 6 mm² Cu line (contact diameter 3.0 mm) can be used according to current-carrying capacity with 39 ampere. The 24 contacts plug can thus be loaded with a max. of 15.6 A / contact (0.4 × 39 A).

NOTE

Designs may differ depending upon the wiring of the modules and be verified with a heating test.

MAX. CONTINUOUS CURRENT

The measured amperage at room temperature (approx. 20 °C) which increases the contact temperature to the limit temperature. The values specified in the catalog apply to either individual contacts or completely assembled inserts/modules, as indicated.

Number of loaded wires	Derating factor
5	0.75
7	0.65
10	0.55
14	0.5
19	0.45
24	0.4
40	0.35
61	0.3

Load and derating factors

Multi-core plastic cable with conductor cross-section of 1.5 to 10 mm² when installed in the open air.

CURRENT-CARRYING CAPACITY DIAGRAM



FOR SINGLE CONTACTS

Measurement made in acc. with IEC 60512-5-2:2002 (DIN EN 60512-5-2:2003) (derived base curve shown = 0.8 × Base curve).

Upper limit temperature: +120 °C.

Termination with nominal cross-section.

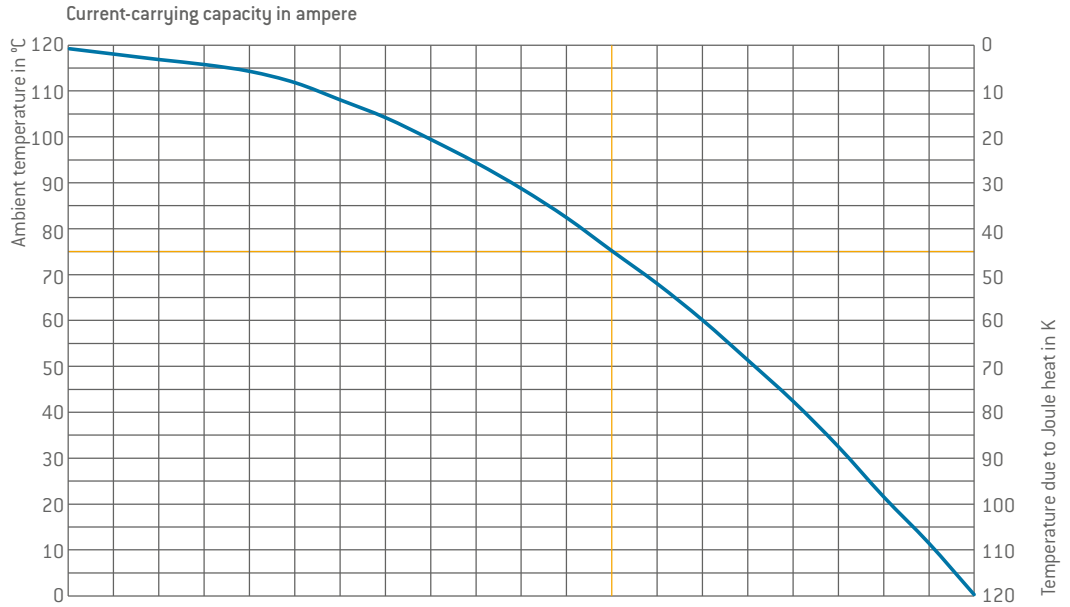

Contact	Contact Ø	Termination cross-section mm²	0	1	2	3	4	5	6	7	8	9	10
ODU SPRINGTAC®	0.76	0.25	0	1	2	3	4	5	6	7	8	9	10
		0.38	0	1.5	2.5	3.5	5	6	7.5	8.5	9.5	11	12
	1.02	0.25	0	1	2	3	4	5	6	7	8	9	10
		0.5	0	1.5	3	4.5	6	7.5	9	10.5	12	13.5	14.5
	1.5	0.25	0	1	2	3	4	5	6	7	8	9	10
		0.5	0	1.5	3.5	5	6.5	8	10	11.5	13	15	16.5
		1	0	2.5	5	7.5	10	12.5	15	17.5	19.5	22.5	24.5
		AWG 16	0	3	6	9	12	15	18	21	24	27	29.5
	2.41	1.5	0	3	6	9	12	15	18	21	24	27	29.5
		0.5	0	1.5	3.5	5	7	8.5	10.5	12	13.5	15.5	17.5
		1	0	2.5	5.5	8	10.5	13	16	18.5	21	23.5	26
		1.5	0	3	6	9	12	15	18	21	24	27	30
		2.5	0	4	8	12	16	20	24	27.5	31.5	35.5	39
	3	AWG 12	0	4.5	9	13.5	18.5	23	28	32	36.5	41	45
		0.5	0	2	4	5.5	7.5	9.5	11.5	13	15	17	18.5
		1	0	2.5	5.5	8	11	13.5	16.5	19	21.5	24.5	27
		1.5	0	3	6	9	12	15.5	19	22	25	28	31
		2.5	0	4	8	12	16	20	25	29	33	37	41
		4	0	6	13	19	25	32	39	45	51	58	64
	5	6	0	6	13	19	25	32	39	45	51	58	64
4		0	6	13	19	25	32	39	45	51	58	64	
10		0	11	21	32	42	53	65	75	85	97	106	
8	16	0	13	26	39	52	65	80	93	106	119	130	
	16	0	12.5	25	37	49	62	75	87	99	111	123	
8	25	0	18	36	52	68	84	100	114	128	142	155	
	16	0	15	29	44	59	74	90	104	118	133	147	
10	25	0	17	34	52	69	87	105	121	137	154	171	
	25	0	18	36	54	72	90	110	127	144	163	180	
	35	0	20	39	59	79	99	120	139	158	179	196	
12	25	0	19	38	57	75	95	115	133	152	172	188	
	35	0	22	44	66	89	111	135	156	178	200	220	
		50	0	24	48	72	96	120	145	170	195	220	240

Nominal current

Max. continuous current

CURRENT-CARRYING CAPACITY DIAGRAM



FOR FULLY EQUIPPED MODULES

Measurement made in acc. with IEC 60512-5-2:2002 (DIN EN 60512-5-2:2003) (derived base curve shown = 0.8 × Base curve). Upper limit temperature: +120 °C. Termination with nominal cross-section.

The values of the 4 contact high voltage module (page 126) correspond to the values of the 5 contacts signal module (page 110).

The values of the 3 contacts power module (page 116) correspond to the values of the 3 contacts power module (page 114).

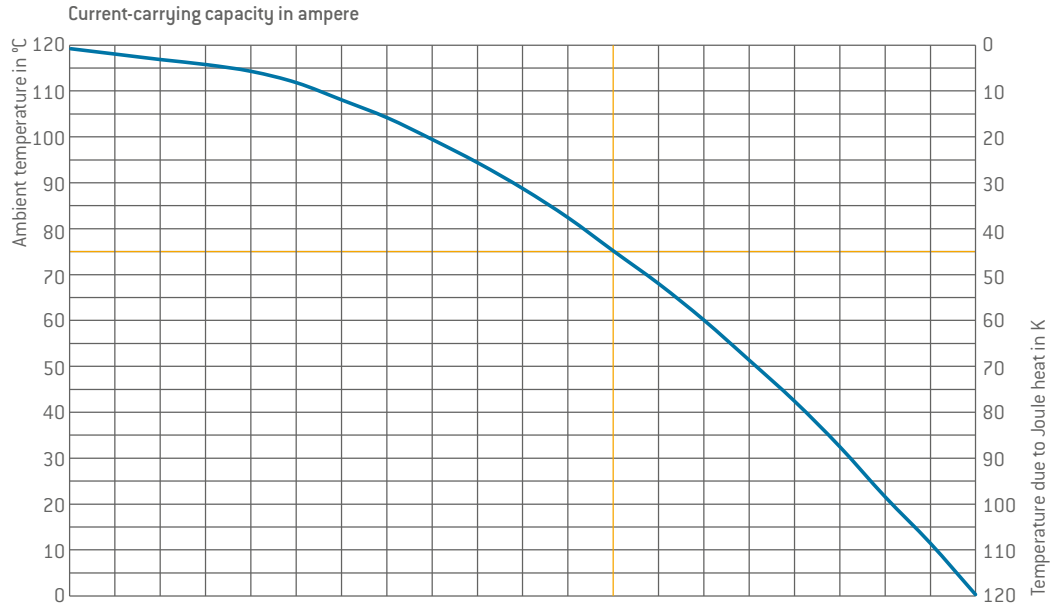

Contact	Module	Contact Ø	Termination cross-section mm ²	0	1	2	3	3.5	4	5	6	7	8	8.5
ODU SPRINGTAC®	10 contacts	0.76	0.25	0	1	2	3	3.5	4	5	6	7	8	8.5
			0.38	0	1	2	3	4	5	6	7	8	9	10
	6 contacts	1.02	0.25	0	1	2	3	4	5	6	7	8	9	10
			0.5	0	1.5	3	4.5	6	7	8	9.5	11	12.5	14
	14 contacts	1.02	0.25	0	1	2	3	3.5	4.5	5	6	7	8	9
			0.5	0	1.5	2.5	4	5	6	7	8.5	9.5	11	12
	5 contacts	1.5	0.25	0	1	2	3	4	5	6	7	8	9	10
			0.5	0	1.5	2.5	4	5	6.5	8	9	10.5	11.5	13
			1	0	2	4.5	6.5	9	11	13	15	17.5	20	22
			AWG 16	0	2.5	5	7.5	10	12.5	14.5	17.5	20	22.5	25
	4 contacts	2.41	1.5	0	2.5	5	7.5	10	12.5	14.5	17.5	20	22.5	25
			0.5	0	1.5	3	4	5.5	7	8	9.5	11	12.5	14
			1	0	2.5	5	7	9	11	13	15.5	18	20.5	23
			1.5	0	2.5	5	7.5	10	12.5	15	18	21	24	27
	3 contacts	3	2.5	0	3.5	7	10	13	16	19	22.5	26	29.5	33
			AWG 12	0	4	8	12.5	16.5	20.5	25	29	33	37	41
			0.5	0	2	3.5	5	6.5	8	9.5	10.5	12	13	14.5
			1	0	2.5	5	7	9.5	12	14	16.5	19	21.5	24
	2 contacts	5	1.5	0	2.5	5.5	8	11	13.5	16	19	21.5	24.5	27
			2.5	0	3.5	7	10.5	14	17.5	21	25	29	33	37
4			0	5	10	15	20	25	30	35.5	41	46.5	52	
6			0	5	10	15	20	25	30	35.5	41	46.5	52	
2 contacts	8	4	0	5.5	11	17	22.5	28	34	39.5	45	50.5	56	
		10	0	9.5	19	28	37.5	47	56.5	66	75	84.5	94	
		16	0	11.5	23	34.5	46	58	70	81	92	103	114	
2 contacts	8	16	0	11.5	23	34	46	58	70	81	92	103	114	
		25	0	16	32	48	64	79	95	109	124	138	152	
ODU LAMTAC®	2 contacts	8	16	0	14	28	42	55.5	70	85	98	111	126	139
			25	0	16	33	49	65	82	100	116	132	149	164

Nominal current

Max. continuous current

LINE CURRENT LOAD



The current-carrying capacity of the individual conductors is frequently lower than that of the individual contacts used. When determining the maximum current-carrying capacity, the lowest value is always to be taken into account.

Laying procedure	Exposed in air	or on surfaces		
		Single-wire lines PVC, PE, PUR, TPE heat resistant	Multi-wire highly flexible lines for hand-held devices, wire/sheath cold-resistant, PVC insulated	Multi-wire movable lines PVC, PE, PUR, TPE standard program harmonised series
Number of loaded wires	1	2	3	4
Nominal cross-section copper conductor in mm ²	Current load in A			
0.14 ¹	3			2
0.25 ¹	5			4
0.34 ¹	8			6
0.5 ¹	12	3	3	9
0.75	15	6	6	12
1	19	10	10	15
1.5	24	16	16	18
2.5	32	25	20	26
4	42	32	25	34
6	54	40		44
10	73	63		61
16	98			82
25	129			108
35	158			135
50	198			168
Current load acc. to:	VDE 0298-4:2013 table 11			

Carrying capacity of cables with a rated voltage of up to 1,000 V and of heat resistant cables. The specification of data does not release one from the need to conduct the test. The original standards remain authoritative for all of the listed technical specifications.

¹ DIN VDE 0891-1:1990.

TECHNICAL TERMS



AMBIENT TEMPERATURE

Temperature of the air or other medium in which a piece of equipment is intended to be used in. (IEC 44/709/CDV:2014 (VDE 0113-1:2014)).

AWG

American Wire Gauge – see page [186](#).

BASE CURVE

See page [188](#).

CHEMICAL RESISTANCE

Many secondary processing procedures use adhesives, cleaning agents or other chemicals on our products. Contact with unsuitable chemicals may have an adverse effect on the mechanical and electrical properties of the insulation and housing materials which specified properties may not be able to withstand. For information on our plastic housings go to page [28](#).

CLEARANCE DISTANCE

The shortest distance in the air between two conductive parts. The insulation coordination is explained in detail from page [183](#).

CONNECTORS

Also known as connectors without contact rating (COC): (IEC 61984:2008 (VDE 0627:2009)). An element which enables electrical conductors to be connected and is intended to create and/or separate connections with a suitable counterpart.

CONTACT RESISTANCE

Total resistance value measured from terminal to terminal. In this case, the resistance is significantly lower than the contact resistance. The specifications are average values.

CORES

Electrical conductor, solid wire or multi-wire strand, with insulation as well as any conductive layers. Cables or leads may have one or more cores.

CREEPAGE DISTANCES

The shortest distance between two conductive parts along the surface of a solid insulation material. This factors in all elevations and recesses in the insulator, as long as defined minimum dimensions are on hand. The insulation coordination is explained in detail from page [183](#).

CRIMP BARREL

A terminal sleeve which can accommodate one or more conductors and be crimped by a crimping tool.

CRIMP CONNECTION (CRIMP TERMINATION)

The permanent, non-detachable and solder-free mounting of a contact to a conductor via deforming or shaping under pressure to make a good electrical and mechanical connection. Executed with crimping tool, press or automatic crimping machine (see page [171](#)).

CRIMP TERMINATION

Termination technology, see crimp connection.

CRIMPING AREA

The specified area of the crimp barrel in which the crimp termination is executed by means of deforming or shaping the barrel under pressure around the conductor.

CURRENT-CARRYING CAPACITY (NOMINAL CURRENT AND MAXIMUM CONTINUOUS CURRENT)

The data relates to adequately dimensioned connection cable in accordance with IEC 60228:2004 (VDE 0295:2005; class 5), so that no significant temperature increase here. The indicated temperature increase takes place through the contact. The specifications are average values.

DEGREE OF POLLUTION

The insulation coordination is explained in detail from page [184](#).

DELIVERY FORM

Connectors can be delivered in assembled form or as individual parts.

DERATING CURVE

See page [188](#).

DERATING FACTOR

According to VDE 0298-4:2013, with connectors and cables over 5 contacts, the heating is greater than it is with individual contacts. For that reason, the aforementioned standard is calculated with a derating factor. See page [189](#).

TECHNICAL TERMS



DERATING MEASUREMENT METHOD

IEC 60512-5-2:2002 (DIN EN 60512-5-2:2003)

See page [188](#).

INSULATOR

Part of a connector which separates conductive parts with different potentials from one another; usually identical to the contact carrier.

KEYING (ORIENTATION)

Arrangement with which differing polarization of otherwise identical connectors prevents interchangeability. This is a good idea if two or more identical connectors are attached to the same device (see also compatible connectors, see page 86).

MATERIALS (STANDARD DESIGN)

Pins and bodies of the sockets are manufactured from a CuZn alloy and silver or gold-plated. The lamellas consist of a CuBe alloy and are also silver or gold-plated. The springwire contact wires consist of a CuSn alloy and are also silver or gold-plated.

MATING AND SLIDING FORCE (UNMATING FORCE)

The force required to fully insert or withdraw pluggable elements without the influence of a coupling or locking device. The higher value of the mating force is caused by the "attachment peak". Subsequently, only the pure sliding force has an effect. In the case of lamella contacts, the data refers to contacts in the lubricated state (status at delivery) and after approx. 30 mating cycles. The forces are/may be higher in new condition (lubricated). In the case of springwire contacts, the data refers to contacts in new condition. The data represents average values with a potential fluctuation of $\pm 50\%$.

MATING CYCLES

Mechanical actuation of connectors by mating and sliding. A mating cycle consists of one mating and sliding action. 10,000 mating cycles are the standard value for ODU TURNTAC and ODU LAMTAC contacts; 50,000 mating cycles for flat sockets and 100,000 mating cycles for springwire contacts. These values only apply under the following circumstances: clean environment, appropriate radial guidance, impeccable counterpins.

MAX. CONTINUOUS CURRENT

The metrologically determined amperage at room temperature (approx. 20 °C) which increases the contact temperature to the limit temperature. The values specified in the catalog apply to either individual contacts or completely assembled inserts / modules, as indicated.

NOMINAL CURRENT

IEC 60512-5-2:2002 (DIN EN 60512-5-2:2003)

See rated current.

NOMINAL SINGLE CONTACT CURRENT LOAD

The current-carrying capacity which each individual contact can be loaded with on its own (see from page [188](#)).

NOMINAL VOLTAGE

The voltage which the manufacturer specifies for a connector and which the operating and performance features relate to.

OPERATING TEMPERATURE FOR ODU-MAC®

See uppermost limit temperature (see page 195).

Single modules may differ from the indicated temperature values. Here you find the technical information on the appropriate pages.

PCB TERMINATION

Production of a conductive connection between the PCB and an element in through-hole assembly, THT (through-hole technology).

RATED CURRENT (NOMINAL CURRENT)

See page [189](#).

RATED VOLTAGE

According to IEC 60512-5-2:2002 (DIN EN 60512-5-2:2003) standard "Value of a voltage which is specified by the manufacturer for a component, device or operating medium and relates to the operating and performance features."

SOLDER CONNECTION (SOLDER TERMINATION)

Termination technology in which a molten additional metal (solder) with a lower melting point than the base materials to be connected is used to attach two metallic materials to one another.

TECHNICAL TERMS



SOLDER TERMINATION

Termination technology, see solder connection.

SPINDLE LOCKING

Locking of two halves of a connector pair by one or more screws, which are generally fluted or have a toggle for easier activation. To extend the provided service life, re-lubrication with a suitable lubricant is recommended.

TERMINATION CROSS-SECTION

The specified cross-sections correspond to a “fine-wire” conductor structure pursuant to IEC 60228:2004 (VDE 0295:2005; Class 5) or a “fine-wire” conductor structure (7/19 wire) according to AWG (ASTM B258-14).

TERMINATION TECHNOLOGIES

Methods for connecting the leads to the electro-mechanical element, such as solder-free connections pursuant to IEC 60352 (DIN EN 60352): crimp, screw connection etc. or soldering connection (see page [170](#)).

TIGHTNESS IEC 60529:2013 (VDE 0470-1:2014)

See protection types on page [182](#).

UPPERMOST LIMIT TEMPERATURE

The maximum permissible temperature at which a connector may be operated. It includes contact heating through current-carrying capacity. With contacts with standard springwire, it amounts to +120 °C, with contacts with standard lamella +150 °C. Please consult ODU for high-temperature applications.

WIRE

Wires (solid conductors) are available with an insulator sleeve and/or electrical shielding. Cables or conductors may be made up of one or more wires.

GENERAL NOTE

The connectors listed in this catalog are intended for use in high voltage and frequency ranges. Suitable precautionary measures must be taken to ensure that people do not come into contact with live conductors during installation and operation. All entries in this catalog were thoroughly reviewed before printing. ODU reserves the right to make changes based on the current state of knowledge without prior notice without being obliged to provide replacement deliveries or refinements of older designs.

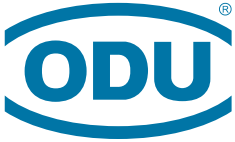

A PERFECT ALLIANCE.

ODU GROUP WORLDWIDE

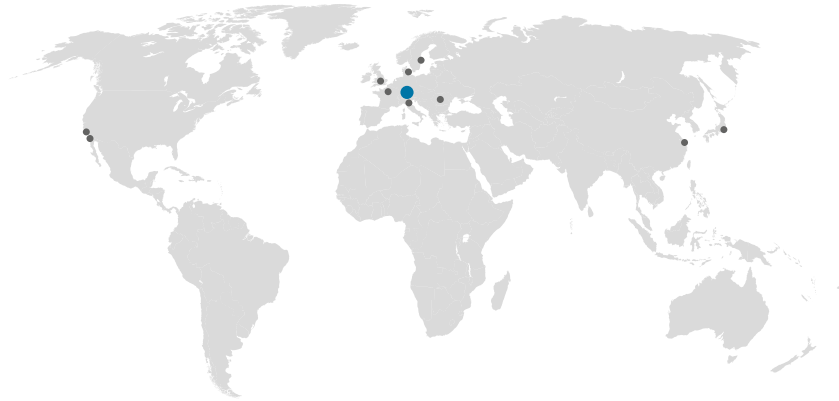

HEADQUARTERS

ODU GmbH & Co. KG

Pregelstraße 11, 84453 Mühldorf a. Inn, Germany
Phone: +49 8631 6156-0, Fax: +49 8631 6156-49, E-mail: zentral@odu.de

SALES SUBSIDIARIES

ODU Denmark ApS

Phone: +45 2233 5335
E-mail: sales@odu-denmark.dk
www.odu-denmark.dk

ODU Japan K.K.

Phone: +81 3 6441 3210
E-mail: sales@odu.co.jp
www.odu.co.jp

ODU-UK Ltd.

Phone: +44 330 002 0640
E-mail: sales@odu-uk.co.uk
www.odu-uk.co.uk

ODU France SARL

Phone: +33 1 3935-4690
E-mail: odu@odu.fr
www.odu.fr

ODU Scandinavia AB

Phone: +46 176 18262
E-mail: sales@odu.se
www.odu.se

ODU-USA, Inc.

Phone: +1 805 484-0540
E-mail: sales@odu-usa.com
www.odu-usa.com

ODU Italia S.R.L.

Phone: +39 331 8708847
E-mail: sales@odu-italia.it
www.odu-italia.it

ODU (Shanghai)

International Trading Co., Ltd.
Phone: +86 21 58347828-0
E-mail: oduchina@odu.com.cn
www.odu.com.cn

Further information and specialized representatives can be found at:

www.odu-connectors.com/contact

PRODUCTION AND LOGISTICS SITES

Germany Otto Dunkel GmbH
China ODU (Shanghai) Connectors Manufacturing Co.Ltd
Mexico ODU Mexico Manufacturing S.R.L. de C.V.
Romania ODU Romania Manufacturing S.R.L.
USA ODU-USA, Inc.
ODU North American Logistics



Simply scan the QR code
to download the entire brochure.

GRASWALD • HEILIGTAC | Passau

ODU-MACSILVER-LINE / ODU-MAC WHITE-LINE / B / 0918 / E