

# Stripline Non-reflective Terminations (Externally Mounted)

## HRM-TM Series



### ■ Features

#### 1. High Performance

These wide bandwidth/high matching non-reflective termination use Hirose Electric original high frequency matching technology.

#### 2. Stripline External Mounting Type

These termination are constructed to mount externally to the housing of a microwave device.

#### 3. High Degree of Matching Type and Economical Type

To suit the application, a type that features a high degree of matching (with VSWR of 1.15 max from DC to 18 GHz) and an economical type (with VSWR of 1.15 max from DC to 8 GHz, and VSWR of 1.25 or less from 8 to 12.4 GHz) are available.

#### 4. Applications

Ideal used as a dummy load for coaxial type circulators, directional couplers, hybrid dividers, and other devices.

### ■ Product Specifications

Ratings	Rated frequency range (Note) Characteristic impedance Maximum Input Power (Note)	DC to 18.0 GHz 50 ohms 1 to 20 W	Operating temperature range Operating relative humidity	-30°C to +65°C 95% Max.
---------	--	--	--	----------------------------

Note: The frequency range and the maximum usable power will differ depending on the model.

Item	Standard	Conditions
1. Vibration	No electrical discontinuity of 1 $\mu$ s or more No damage, cracks, or parts dislocation	Frequency of 10 to 2,000 Hz, overall amplitude of 1.52 mm, acceleration of 98 m/s <sup>2</sup> for 2 hours in each of 3 directions
2. Shock		Acceleration of 490 m/s <sup>2</sup> , sine half-wave waveform, 3 cycles in each of the 3 axis
3. Temperature cycle	No damage, cracks, or parts dislocation	Temperature: -55°C → +15°C to +35°C → +85°C → +15°C to +35°C Time: 30 → 15 max. → 30 → 15 max. (Minutes) 5 cycles

● The test method conforms to MIL-STD-202.

### ■ Materials

Part	Material	Finish
Body (Note)	Brass	Nickel plating
Insulator	PTFE	—
Contacts	Brass	Gold plating
Resistor	Metal film	—

Note: HRM-TM-025 has stainless steel body and has received gold plating.

### ■ Ordering Information

**HRM - TM - 025 - 8 (40)**  
 ①      ②      ③      ④      ⑤

① Series Name: HRM Series	③ Power (Examples) 1: 1 W
② Indicates a non-reflective termination	(Exception) 025: 1 W
	④ Suffix
⑤ (40): RoHS compliant	

## ■ Specifications

Part Number	Frequency Range (Ghz)	V.S.W.R. (MAX)	Power (W)	Direct Current Resistance (Ohms)	Temperature (°C Max)	Operating Temperature Rang (°C)	Heat Sink Temperature at Maximum Load (°CMax)	Operating Temperature Rang (μN · m)	Weight (g)
HRM-TM-025(40)	DC~10	1.20	1	50±1.5	40	-30~+65	+65	294	2.5
HRM-TM-025-6(40)	DC~18	1.20	1	50±1.0	40	-30~+65	+65	392	3
HRM-TM-025-8(40)	DC~18	1.20	1	50±1.0	40	-30~+65	+65	392	3.5
HRM-TM-025-9(40)	DC~12	1.20	1	50±1.5	40	-30~+65	+65	392	3.5
HRM-TM-025-10(40)	DC~4 4~8	1.08 1.12	1	50±1.0	40	-30~+65	+65	392	3
HRM-TM-025-11(40)	DC~18	1.20	1	50±1.0	40	-30~+65	+65	392	3
HRM-TM-025-17(40)	DC~8 8~12.4	1.15 1.25	1	50±1.5	40	-30~+65	+65	392	3
△ HRM-TM-10-2(40)	DC~12.4 12.4~18	1.20 1.25	10	50±1.5	56	-10~+65	+65	392	3
△ HRM-TM-10-4(40)	DC~12.4 12.4~18	1.20 1.25	10	50±1.5	56	-10~+65	+65	392	3

※1 9.80665N · m=1kgf · m  
 0.980665μN · m=1kgf · cm  
 (Example)392μN · m≒400kgf · cm

△ Beryllia is used in this product. Please follow associated laws when disposing.

## ■ Typical Data

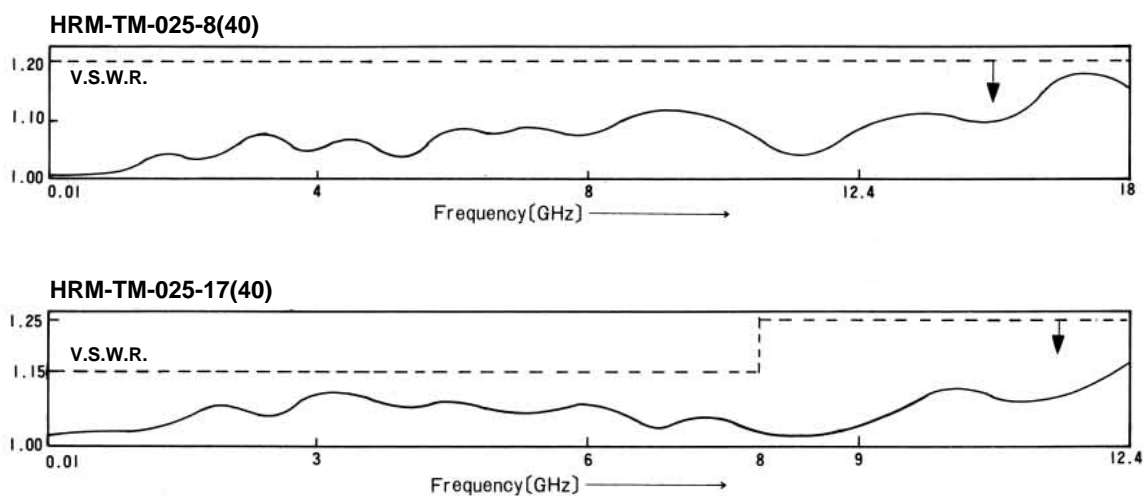

HRM-TM Series Stripline Non-reflective Terminations (Externally Mounted)

External Dimensions

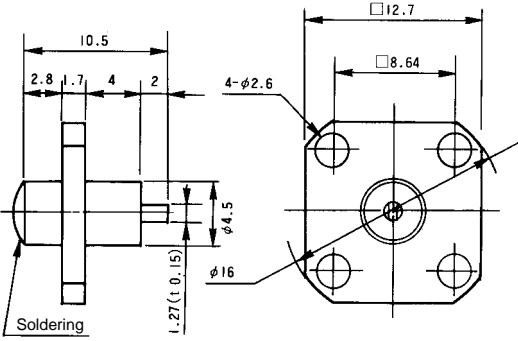

HRM-TM-025(40)

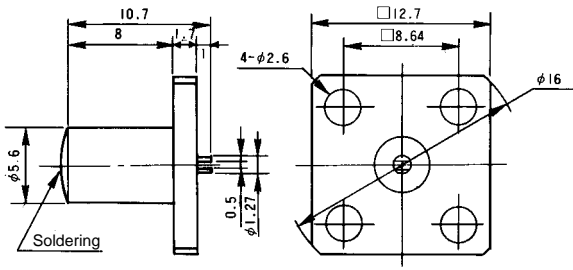

HRM-TM-025-6(40)

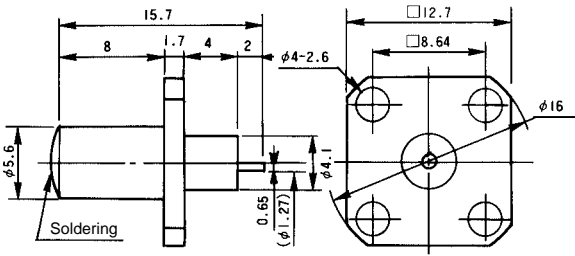

HRM-TM-025-8(40)

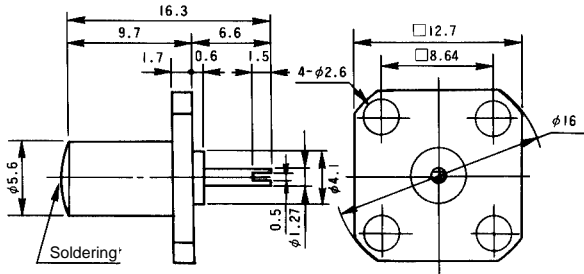

HRM-TM-025-10(40)

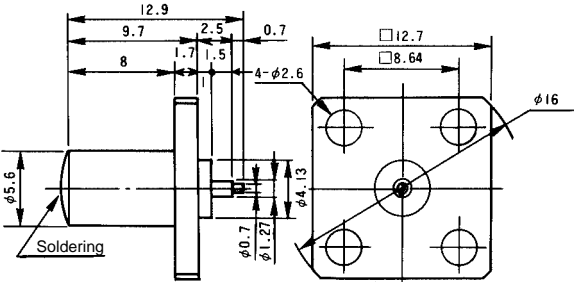

HRM-TM-025-11(40)

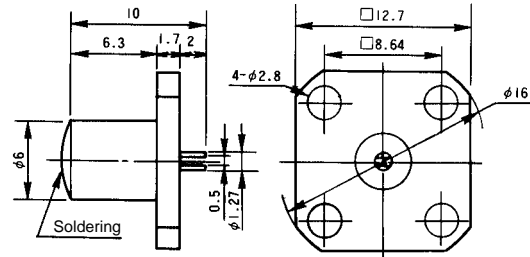

HRM-TM-025-17(40)

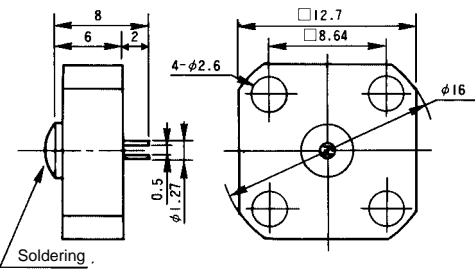

HRM-TM-10-2(40)

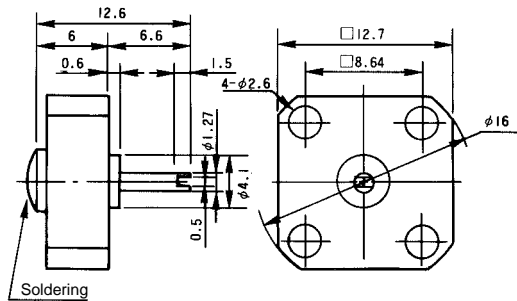

HRM-TM-10-4(40)

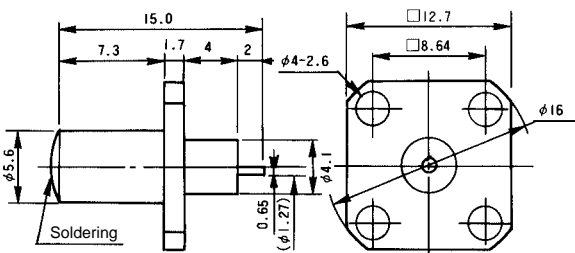

HRM-TM-025-9(40)